



Lubrication & Fluid Transfer

GREASE GUNS

GREASE GUN ACCESSORIES

GREASE FITTINGS

GREASE PUMPS

GREASE PUMP ACCESSORIES

WATER, CHEMICAL AND OIL PUMPS

OIL AND FUEL PUMPS

FUEL AND GASOLINE PUMPS

OIL DRAINS

DRUM HANDLING

***OVER 20
NEW PRODUCTS***

These industrial quality products are manufactured with the professional in mind.

GREASE GUNS



Lever Action - Standard Duty

350151 / JLGG-14S

- Uses standard **14 oz. grease cartridge** or can be bulk filled
- Rugged electro-static epoxy coated finish resists corrosion
- Deep knurling for non-slip grip
- Heavy duty steel barrel for long life
- Machined steel head protects hardened steel plunger
- V-handle posi-lock follower rod for sure grip and easy filling in any position
- Ideal for home, farm, maintenance and shop use
- Complete with 6" rigid pipe extension and coupler
- Delivers 1 gm / stroke or 1 oz. / 28 strokes
- Produces up to 6,000 PSI



Die cast head

Lever Action - Heavy Duty

350152 / JLGG-14HD

- A premium, heavy duty grease gun built tough for the professional, industrial markets
- Added filler nipple allows three way loading; bulk, filler pump or standard **14 oz. cartridge**
- Air bleeder valve easily purges unwanted air
- Variable stroke for working in confined areas
- Rugged electro-static epoxy coated finish resists corrosion
- Deep knurling for non-slip grip
- Heavy duty steel barrel for long life
- Die cast head protects hardened steel plunger
- T-handle posi-lock follower rod for sure grip and easy filling in any position
- Comfortable sure grip rubber handle makes pumping easy and convenient
- **Complete with 6" rigid extension and heavy duty coupler**
- A must for heavy maintenance, industrial, automotive and farm use
- Delivers 1 gm / stroke or 1oz. / 28 strokes
- Produces up to 10,000 PSI

Comes with rigid extension



Die cast head

Pistol Grip - Heavy Duty

350155 / JPGG-14HD

- Pistol grip design offers convenient one-handed operation
- Die cast head protects hardened steel plunger
- Uses standard **14 oz. grease cartridge** or can be bulk filled
- Rugged electro-static epoxy coated finish resists corrosion
- Deep knurling for non-slip grip
- T-handle posi-lock follower rod for sure grip and easy filling in any position
- **Includes 4" rigid pipe extension, 18" flexible hose and heavy duty coupler**
- Delivers 0.50 gm / stroke or 0.70 oz. / 40 strokes
- Produces up to 5,000 PSI

Comes with rigid and flex extension

High Pressure / High Volume - Heavy Duty

350156 / JPGG-14HPHV

- Convenient lever mounted switch converts gun for high pressure or high volume use while maintaining one-hand operation
- Threadless barrel with quick connect lever allows for super-fast reloading with no danger of crossing threads
- Uses standard **14 oz. grease cartridge** or can be bulk filled
- Complete with air bleeder and bulk loader valves
- Deep knurling for non-slip grip
- T-handle posi-lock follower rod for sure grip and easy filling in any position
- **Includes 12" Heavy Duty flexible hose and coupler**
- Delivers 0.90 gm / stroke or 1 oz. / 31 strokes
- Produces up to 7,000 PSI



Single Shot Air Powered - Heavy Duty

350161 / JAGG-14P

- A premium heavy duty air powered grease gun for the most demanding professional user
- Intermittent action delivers one shot of grease for every pull of the trigger
- Added filler nipple allows 3 way loading; bulk, filler pump, or standard **14 oz. cartridge**
- Heavy duty die cast aluminum head
- Precision honed barrel for fast action
- Air pressure 40 – 120 PSI at 1 cfm or greater
- T-handle posi-lock follower rod for sure grip and easy filling in any position
- Complete with male quick coupler air fitting
- Delivers 0.90 gm / shot or 1.30 oz. / 40 shots
- Produces up to 4,800 PSI
- **Includes 6" rigid extension, 12" flexible hose and heavy duty coupler**



Comes with rigid and flex extension

Continuous Flow Air Powered - Heavy Duty

350162 / CFAGG-14HD

- Automatic continuous flow of grease while trigger is depressed
- 40:1 Pump Ratio
- Minimum inlet air pressure 40 PSI to Maximum 120 PSI (2.7 to 10.3 bar)
- Develops up to 4,800 PSI pressure
- Added filler nipple allows 3 way loading; bulk, filler pump, or standard **14 oz. cartridge**
- Air vent valve included for releasing air pockets
- Output per stroke 14 oz. per minute
- Lubricant up to NLGI #2 Grease
- Air Inlet 1/4-18 NPT
- Grease Outlet 1/8-27 UNPT
- **Includes 6" rigid extension, 12" flexible hose and heavy duty coupler**





Pistol Grip - Mini Style - Heavy Duty

350171 / JMPG-16

- Convenient pull type trigger for easy one hand operation
- Die cast head
- Textured zinc plated finish for non slip grip
- Uses standard **3 oz. grease cartridges** or can be bulk filled
- T-handle posi-lock follower rod for sure grip
- Complete with **4" rigid pipe extension and professional coupler**
- Produces up to 3,500 PSI
- Delivers 0.40 gm / stroke or 0.60 oz. / 40 strokes



Pre-loaded with NLGI Grade 2 grease

Push Type - Mini Tool Box Style

350173 / JPTG-1

- Perfect tool box companion for lubrication of tools on the job
- Universal connector fits all standard fittings
- Comes pre loaded with NLGI grade 2 grease
- Can be re-filled
- Transparent barrel provides clear view of remaining grease
- Sealed design to prevent leakage
- Pre-loaded with NLGI Grade 2 grease

GREASE GUN ACCESSORIES

High Pressure - Regular Style

- Heavy duty high pressure (11,600 PSI burst pressure)
- Working pressure 3,500 PSI

PROD. NO.	MOD. NO.	Length	Type	Thread
350181	JFH-12	12"	Flexible	1/8" NPT
350182	JFH-18	18"	Flexible	1/8" NPT



Regular



Spring Style



Super Heavy Duty

Grease Gun Hoses

- Replacement whip hoses • Polyamide inner tube with polyurethane outer tube, reinforced with highly tear resistant polyester

High Pressure - Spring Style

- Fitted with heavy duty spring for added safety, strength and life
- Heavy duty high pressure (11,600 PSI burst pressure)
- Working pressure 3,500 PSI

PROD. NO.	MOD. NO.	Length	Type	Thread
350201	JFH-12SP	12"	Flexible	1/8" NPT
350202	JFH-18SP	18"	Flexible	1/8" NPT

High Pressure - Super Heavy Duty

new

- Two layer construction consisting of a polyamide inner tube with a tough polyurethane sheath, reinforced diagonally with highly tear resistant polyester
- Extra large inner diameter is ideal for cold weather use
- Spring guard adds strength and safety
- For hand and air operated grease guns and control valves
- Working pressure 5,800 PSI • Burst pressure 13,775 PSI



PROD. NO.	MOD. NO.	Length	Type	Thread
350215	JFH-12HP	12"	Flexible	1/8" NPT
350216	JFH-18HP	18"	Flexible	1/8" NPT

Quick Change Coupler Adaptors



7 PC Quick Change Coupler Set

350213 / JOCC-7S

- Quick change feature snaps directly onto jaw type couplers – no need to remove hydraulic coupler to change accessories
- Instantly converts jaw type couplers for fine line greasing for access to confined areas
- Protective sleeve secures connection
- Ideal for applications where fittings are in hard-to-reach areas
- For hand operated grease guns
- **Set contains one of each below:**

Recessed Lube Adaptor

350208 / JRLA-1

- 4" length, tip diameter 0.22"
- For push on greasing of fittings where obstruction will not allow use of regular coupler



Right Angle Coupler

350211 / JRAC-2

- Working pressure 1,000 PSI
- Particularly useful in low height applications
- Polyurethane seal fits perfectly on grease fitting



Needle Nose Adaptor

350210 / JNND-2

- 1-1/2" needle length, diameter 0.156"



Grease Injector Needle

350206 / JGIN-15

- Lubricates in extremely tight places including U-joints and sealed bearings
- Fits directly on jaw type couplers
- 18 gauge stainless steel
- 1-1/2" long
- With protective plastic cover



Seal-Off Dispenser

350212 / JSOD-1

- Used for lubricating cars with grease plugs
- Oil and grease resistant rubber tip



90° Angle Lube Adaptor

350209 / JALA-1

- .019" diameter



Needle Nose Dispenser

350205 / JNND-1

- For dispensing fine line of grease
- Allows contact with flush or hard-to-reach fittings in inaccessible areas
- 1-1/2" needle length, diameter 0.156"
- 1/8" NPT threads



Grease Gun Couplers

- For hand operated grease guns
- Professional industrial quality

4 Jaw - Heavy Duty

350203 / JPDC-4

- Hardened body withstands high pressure without deformation
- Working pressure 6,000 PSI
- 1/8" NPT threads



Right Angle - Heavy Duty

350204 / JRAC-1

- Unique design for greasing fittings in hard to reach areas
- Particularly useful in low height applications
- Polyurethane seal fits perfectly on grease fitting
- Working pressure 1,000 PSI
- 1/8" NPT threads



Grease Gun Holders

Grease Gun Holder **350185** / JGGH-1

- Conveniently mounts any 2-1/4" O.D. grease gun to almost any surface



Grease Gun Holder - Heavy Duty

350189 / JGGH-2HD

- Designed specifically for mounting on construction equipment, farm vehicles, tractor trailers and other vehicles subject to high vibration
- Heavy duty spring retains gun securely and allows easy removal and replacement
- Four mounting bolts for secure attachment
- Fits 2-1/4" and 2-1/2" barrel diameters



new



350218

350217

new

Button Head - Heavy Duty

- Specifically designed to fit 5/8" and 7/8" button head fittings found on heavy machinery
- Metal seal resists wear

PROD. NO.	MOD. NO.	Threads	Working Pressure
350217	JBHC-58	1/8" NPT	6,000 PSI
350218	JBHC-78	1/8" NPT	7,500 PSI

Swivel Type - Heavy Duty

350207 / JSJC-360

- Built in 360° swivel locks in eight positions
- Working pressure 7,000 PSI
- 1/8" NPT threads
- Fully hardened 3 jaw construction



new

101 PC S.A.E. Grease Fitting and Tool Set – Heavy Duty

350263 / JGFK-101

- Contains 99 S.A.E. Grease Fittings and 2 multi-purpose fitting tools

CONTENTS

1/8"-27 NPT: 22 Straight, 5 x 30°, 10 x 45°, 10 x 65°, 10 x 90°
 1/4"-28 S.A.E.-LT: 22 Straight, 10 x 45°, 10 x 90°

350261 (JGFT-14) and **350262** (JGFT-18) fitting tools



350263

new

40 PC S.A.E. Stainless Steel Grease Fitting Set - Heavy Duty

350264 / JGFK-40SS

- Stainless steel fittings for use in marine and other corrosive environments

CONTENTS

1/8"-27 NPT: 10 straight, 5 x 45°, 5 x 90°
 1/4"-28 SAE-LT: 10 straight, 5 x 45°, 5 x 90°



350264

Sets - Heavy Duty

PROD. NO.	MOD. NO.	Type	Pieces	Contents
350257	JGF-8S	S.A.E.	8	2 each: 1/4" - 28 Straight, 1/8" - 27 Straight, 1/8" - 27 45°, 1/8" - 27 90°
350258	JGF-8M	Metric	8	2 each: M6 x 1 Straight, M6 x 1 45°, M6 x 90°, M8 x 1
350259	JGF-80S	S.A.E.	80	15 x 1/4" - 28 Straight, 10 x 1/4" - 28 45°, 10 x 1/4" - 28 90°, 25 x 1/8" - 27 Straight, 10 x 1/8" - 27 45°, 10 x 1/8" - 27 90°
350260	JGF-80M	Metric	80	20 x M6 x 1 Straight, 10 x M6 x 1 90°, 15 x M8 x 1 Straight, 10 x M8 x 1 90°, 15 x M10 x 1 Straight, 10 x M10 x 1 90°



350257 / 350258

Grease Fittings

- Conforms to SAE, DIN, BS and JIS standards
- EN-1A steel with zinc plating
- Heat treated to a minimum of HRC83



350259 / 350260

GREASE FITTINGS



STRAIGHT
350251 / 350254



45°
350252 / 350255



90°
350253 / 350256



new



350261



350262

10 Packs - Heavy Duty

PROD. NO.	MOD. NO.	Type	Pieces	Thread	Hex Size
350251	JGF-142800	Straight Fittings	10	1/4" – 28 S.A.E.	5/16"
350252	JGF-142845	45° Fittings	10	1/4" – 28 S.A.E.	3/8"
350253	JGF-142890	90° Fittings	10	1/4" – 28 S.A.E.	3/8"
350254	JGF-182700	Straight Fittings	10	1/8" – 27 NPT	7/16"
350255	JGF-182745	45° Fittings	10	1/8" – 27 NPT	7/16"
350256	JGF-182790	90° Fittings	10	1/8" – 27 NPT	7/16"

Grease Fitting Unblocker

350265 / JFUT-100

- Opens clogged grease fittings and loosens hardened grease joints
- Tapping tool with a hammer forces a light viscosity oil into the fitting, breaking up and removing dirt and debris
- Excellent for maintaining bearings, control arms, king pins etc.
- Built-in hand guard for operator protection
- Complete with coupler and flex hose for reaching recessed fittings
- Includes 2 spare piston seals

4 Way Fitting Tools

- Handy multi-purpose fitting tools
- Wrench, tap and extractor in one
- Removes worn and broken fittings, re-taps threaded holes, installs new fittings
- Works with straight and angled fittings

PROD. NO.	MOD. NO.	Application
350261	JGFT-14	<ul style="list-style-type: none"> • Tap repairs 1/4"-28 S.A.E. threaded holes • Wrench removes and installs 5/16" and 3/8" hex fittings
350262	JGFT-18	<ul style="list-style-type: none"> • Tap repairs 1/8"-27 NPT threaded holes • Wrench removes and installs 7/16" and 3/8" hex fittings

Grease Gun Filler Pump

350158 / JGFP-03

- Zinc die cast head and adjusting flange
- 18" zinc plated pump body
- Epoxy coated, corrosion resistant 12" drum cover
- All steel foot valve
- **Fits 25 - 50 lb / 5 gallon pails**
- Designed to load bulk or combination grease guns
- Delivers 28 gms on 1 oz. / stroke
- Suitable for use with light and medium density grease

JET Heavy Duty 50:1 Grease Pumps

- Designed for everyday use in shops, factories and maintenance departments for quick and efficient dispensing of grease
- All units dispense 27 ounces per minute. Simply connect to your air system, pull the trigger and let these powerful pumps do the work
- Each unit comes with 18" whip hose/coupler, control valve, 4 meters of hose, drum cover and follower plate

50 lb Air Operated Grease Pump Kit - Heavy Duty

350306 / JAGP-25

- 50:1 Air Operated Grease Pump (25-50 lb container)
- Requires 70-115 PSI operating pressure
- Pumps up to 1.76 lbs per minute (27 ounces)
- 82 dB noise level
- 13' delivery hose
- 12-13/64" drum cover
- 10-3/8" follower plate
- Control valve
- Shipping Weight: 23 lb (10kg)



120 lb Air Operated Grease Pump Kit - Heavy Duty

350307 / JAGP-120

- 50:1 Air Operated Grease Pump (120 lb container)
- Requires 70-115 PSI operating pressure
- Pumps up to 1.76 lbs per minute (27 ounces)
- Comes with 4 wheel roll around cart
- 82 dB noise level
- 13' delivery hose
- 15" drum cover
- 14-1/2" follower plate
- Control valve
- Shipping Weight: 38 lbs (17 kg)



new

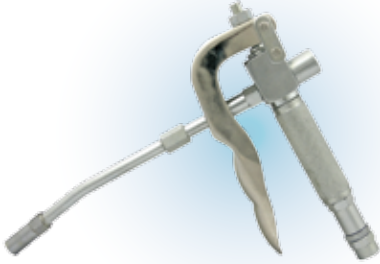

Control Valve

350311 / JAPG-CV

- Premium quality, top of the line grease control valve for use with air operated equipment
- Provides continuous grease flow with trigger fully depressed
- Inlet thread: 1/4" NPT (F), Outlet thread: 1/8" NPT (F)

new



Booster Grease Control Valve

350312 / BGCV-1

- Heavy duty grease control valve with built-in pressure boost mechanism
- Repeated actuation of handle boosts line pressure from 6,000 PSI up to 10,000 PSI
- Provides continuous flow with handle fully depressed
- Extremely useful for unblocking clogged fittings
- Complete with 6" rigid extension and 4 jaw heavy duty coupler
- Inlet thread 1/4" NPTF, outlet thread 1/8" NPT



360° Swivel

350391 / JAGP-SW

- 1/4"(M) x 1/2"-27(M)
- Installed between the delivery hose and grease control valve allowing greater mobility and control of the grease control valve
- Heavy duty steel construction with ball bearings for smooth operation and unrestricted movement
- Swivel joints are hardened for durability and greater wear resistance
- Maximum working pressure – 6,000 PSI

Polyethylene Siphon Pumps

- Easy to use pumps siphon liquids to lower levels automatically once started
- 6 to 7 strokes of the bellows primes pump requiring no further operation
- Vent cap stops siphoning when opened
- Bellows can be continuously operated to pump liquids to higher levels than pump is installed
- Complete with flexible discharge hose
- **Recommended use:** water-based fluids, detergents, waxes, soaps, antifreeze, mild acid solutions, and other lightweight non-flammable liquids
- **Do not use with:** concentrated acids, acetone, benzene, fuels, fluids incompatible with wetted components, or liquids above 60°C (140°F)

PROD. NO.	MOD. NO.	Discharge	Bung Size	Fits	Wetted Components	Discharge Hose Length
350110	JPSP-2	2 GPM (6.5 LPM)	1-1/2"	5 gal / 5-20 L pails	Polyethylene	21-1/2"
350111	JPSP-5	5 GPM (17.5 LPM)	2"	55 gal / 205 L drums	Polyethylene and Polypropylene	46-1/2"
350112	JPSP-7	7 GPM (21 LPM)	2"	55 gal / 205 L drums	Polyethylene and PVC	47-3/4"

Chemical Pump - Nylon Body

350109 / JNCP-14

- Self-priming vertical lift pump
- **Recommended use:** lacquer thinners, acetone, MEK, antifreeze, detergents, windshield washer fluids, mild acids, weed killer, water and glycerine
- **Fits 15 – 55 gallon drums**
- Delivers 14 oz. per stroke
- **Do not use with:** strong acids or gasoline
- Wetted components: nylon, polypropylene, stainless steel and PTPE

Chemical Pump - Polypropylene Body

350108 / JPCP-14

- Self-priming vertical lift pump
- **Recommended use:** antifreeze, detergents, windshield washer fluid, mild acids and glycerine
- **Fits 15 – 55 gallon drums**
- Delivers 14 oz. per stroke
- **Do not use with:** water, strong acids, lacquers, acetone and gasoline
- Wetted components: polypropylene, steel, Viton®

new



350110



350111

350112



350109



350108

WATER, CHEMICAL & OIL PUMPS



new

Plastic Lever Pump

350113 / JPLP-100

- Lever action barrel pump designed for use with high viscosity fluids
- Special design makes pumping thick liquids easier reducing operator fatigue
- Built in 2" bung adapter with lock nut allows pump handle to be positioned conveniently
- Air vent cap stops siphon action
- Delivers 500 ml per stroke
- **For use on 15 – 55 gallon (50 – 205 litre) drums**
- Complete with 6' corrugated discharge hose
- **Recommended use:** water-based fluids, detergents, waxes, soaps, antifreeze, windshield washer fluid, hydraulic oils, lubricants, pesticides and herbicides, Adblue®, Urea, DEF and other non-flammable liquids
- **Do not use with:** concentrated acids, acetone, benzene, fuels, thinners, solvents or fluids incompatible with wetted components
- Wetted components: polyacetal, polypropylene, polyethylene, PVC, Viton®

Viton® is a registered trademark of DuPont Performance Elastomers LLC
Adblue® is a registered trademark of the VDA

Oil Cans

- Industrial quality
- Brass pump
- Electro-static, corrosion resistant epoxy coating
- Complete with flex hose and rigid spout

350125



OIL AND FUEL PUMPS

Brass Pump Oil Cans

PROD. NO.	MOD. NO.	Capacity
350121	JOC-180	6 oz. / 180 ml
350122	JOC-300	10 oz. / 300 ml
350124	JOC-500	16 oz. / 500 ml
350125	JOC-700	24 oz. / 700 ml

All models complete with both flex and rigid spouts



Barrel Pump - Rotary - Heavy Duty

350103 / HRP-25

- Sturdy cast iron body with precisely machined cast iron vanes for better draw and smoother delivery
- Hi-Nitrile rubber pump seals
- Delivers 5 litres or 1.30 gallons per 20 revolutions
- Dual directional operation – pumps in either direction
- **Recommended use:** diesel, kerosene, heating oils, motor oils, lubrication oils (up to SAE 90) and other non-corrosive media
- **Do not use with:** gasoline, antifreeze, solvents, acids or water based media
- Comes with suction tube, 2" cast iron bung nut and steel discharge spout

Plastic Rotary Pump

350114 / JPRP-200

- Rotary barrel pump designed for use with media which cannot be pumped with cast iron or steel pumps
- Glass filled polypropylene body with Ryton® vanes, Viton® seals and stainless steel hardware for maximum resistance to chemicals
- Strainer fitted on suction tube prevents contaminants from entering pump
- Delivers 1 litre per 4 turns
- Includes 2" threaded bung adapter
- For use on 15 – 55 gallon (50 – 205 litre) drums
- **Recommended use:** water-based fluids, antifreeze, Adblue®, urea, DEF, benzene, detergents, glycerine, acids, chemicals, oils, diesel, kerosene
- **Do not use with:** acetone, lacquer, mineral oils, solvents, turpentine, gasoline or fluids incompatible with wetted components
- Wetted components: polypropylene, Ryton®, Viton®, stainless steel

Litre Stroke Pump

350115 / JLSP-100

- Designed to dispense exact amounts of petroleum based fluids
- Adjustment screw allows pump to be set to deliver 1 litre or 1 quart per stroke
- Rack and pinion mechanism is very precise; ideal for applications requiring metered delivery
- Spring loaded drain-back tube returns overflow to the drum via the suction tube
- Handle can be padlocked for security
- Lock nut allows outlet to be positioned in any direction
- Complete with 2" bung adapter
- For use on 15 – 55 gallon (50 – 205 litre) drums
- **Recommended for:** gear and lube oils, petroleum based fluids, diesel fuel, kerosene
- **Do not use with:** water based, corrosive fluid, gasoline or liquids incompatible with wetted components
- Wetted components: steel, aluminum, nitrile rubber and acetal



Viton® is a registered trademark of DuPont Performance Elastomers LLC

Adblue® is a registered trademark of the VDA

Ryton® is a registered trademark of Chevron Phillips Chemical

OIL AND FUEL PUMPS



Barrel Pump - Lever Action - Heavy Duty

350105 / JLBP-01

- Suitable for use with all oil based fluids
- Fits 15 – 55 gallon drums
- Rugged epoxy coated pump assembly
- Tough all steel foot valve and piston valve
- Delivers 300 ml or 10 oz. / stroke
- Complete with 2 piece draw tube



Bucket Pump - Lever Action - Heavy Duty

350106 / JLBP-02

- Suitable for transfer of transmission, differential and heavier oils
- Delivers 16 oz. / stroke
- Zinc die cast head and adjustable flange
- Fits 25 - 50 lb / 5 gallon pails
- Epoxy coated, corrosion resistant 12" drum cover
- 18" zinc plated pump body
- Complete with 48" fuel resistant soft PVC hose with nozzle



Suction Gun

350157 / JS GG-18

- Rugged **18 oz. capacity** suction gun for draining and filling differentials, clutches and transmissions
- Does not require priming
- Heavy duty steel barrel for long life
- Electro-static epoxy coated finish resists corrosion
- Deep knurling for non-slip grip
- T-handle posi-lock follower rod for sure grip
- Complete with flexible vinyl hose
- For use with any non-corrosive lubricants

new

Brass Transfer Pump

350159 / JBTB-100

- Portable hand pump for quick and easy transferring or evacuating of a wide variety of media
- Non-corroding premium brass construction
- Self-priming
- Complete with 24" of 1/2" discharge hose and 40" of 1/4" suction hose
- Can be used to drain oil or transmission fluids through the dipstick hole – ideal for boats
- Transfer fluids from one container to another without lifting either
- Pumps 3.2 oz. (100ml) per stroke
- Wetted components: brass, neoprene

Rotary Fuel Pump

350116 / JRFP-10

- Industry standard for rotary pumps
- Designed for severe use in extreme weather conditions
- Solid cast iron body CNC machined to exacting tolerances
- High quality sintered powder metal 3 vane rotor operates in a highly finished pumping chamber
- Non-wearing graphite vanes and graphite seal allows pumping of a wide variety of fluids including those with up to 15% ethanol
- Discharges up to 10 GPM (38 LPM)
- Complete with 2" bung adapter and telescopic suction tube with strainer
- **For use on 15 – 55 gallon (50 – 205 litre) drums**
- **Recommended use:** gear and lube oils, petroleum based fluids, diesel fuel, kerosene and gasoline
- **Do not use with:** water based, corrosive fluids or fluids incompatible with wetted components
- Wetted components: cast iron, steel, graphite, paper, polypropylene

Rotary Fuel Pump Kit

350117 / JRFP-10K

- Industry standard for rotary pumps
- Designed for severe use in extreme weather conditions
- Complete with 8' anti-static discharge hose and non-sparking aluminum nozzle and nozzle holder for re-fueling operations
- Solid cast iron body CNC machined to exacting tolerances
- High quality sintered powder metal 3 vane rotor operates in a highly finished pumping chamber
- Non-wearing graphite vanes and graphite seal allows pumping of a wide variety of fluids including diesel with up to 15% ethanol
- Discharges up to 10 GPM (38 LPM)
- Complete with 2" bung adapter and telescopic suction tube with strainer
- **For use on 15 – 55 gallon (50 – 205 litre) drums**
- **Recommended for:** gear and lube oils, petroleum based fluids, diesel fuel, kerosene and gasoline
- **Do not use with:** water based, corrosive fluid, or fluids incompatible with wetted components
- Wetted components: cast iron, steel, graphite, paper, polypropylene



new



new





new



3:1 High Volume Rotary Fuel Pump

350118 / JRFP-300

- Geared rotary barrel pump turns rotor 3 times for each turn of the handle
- Dispenses up to 55 gallons (205 litres) in just 3 minutes
- Ideal for use where volume fuel dispensing is required
- Die cast aluminum pump body with die cast zinc rotor and vanes
- Built-in nozzle holder
- Handle can be locked for security
- Complete with 6' fuel resistant discharge hose
- Complete with 2" bung adapter and 3 piece threaded tube
- **For use on 15 – 55 gallon (50 – 205 litre) drums**
- **Recommended use:** gasoline, diesel fuel, and kerosene
- **Do not use with:** water based or corrosive liquids, solvents, acids, alkalis or fluids incompatible with wetted components
- Wetted components: aluminum, zinc, steel, NBR and PVC Nitrile

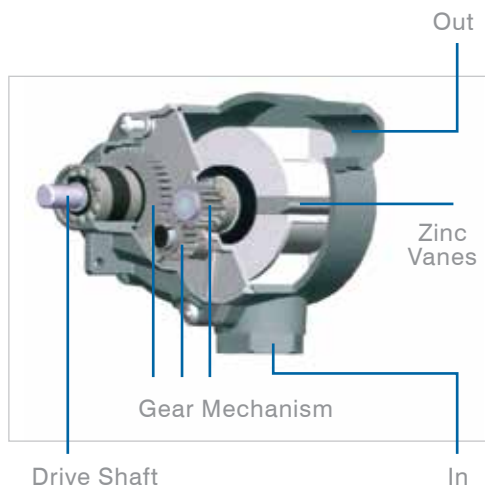

Diaphragm - Litre Stroke - Heavy Duty

350107 / JDDP-1000

- High volume double action pump delivers on both strokes for fast fuelling
- Delivers 1 litre per cycle or 1 gallon / 5 strokes
- **Fits 15 – 55 gallon drums**
- Die cast aluminum construction
- Stainless steel piston and fuel resistant diaphragm
- Extra heavy duty steel handle with security locking latch
- Complete with 2" bung adaptor, 8' discharge hose and telescoping suction tube
- **Recommended use:** gasoline, diesel fuels, fuel oil, motor oil
- **Do not use with:** corrosive liquids, solvents, alkalis
- Wetted components: aluminum, steel, stainless steel, polyacetal, NBR

OIL DRAINS



LUBRICATION & FLUID TRANSFER



new



90 Litre Waste Oil Drain - Heavy Duty

350511 / JOIDR90

- Large 90 litre steel recovery tank
- 78" long drainage hose
- Tank mounted oil-level sight gauge
- Convenient tool tray
- 16" diameter collection funnel holds 18 litres of oil
- 23" diameter collection funnel adaptor included to expand oil catch area
- Shut off valve between collection funnel and tank allows fluid inspection prior to draining oil
- Uses air to pressurize tank, allowing quick and easy fluid evacuation (maximum 7 PSI)
- Pressure regulator included
- Adjustable bowl height from 40" to 79" high
- Uses gravity to drain waste oil from engines, gear boxes, and differentials
- Shipping weight: 60 lb (27 kg)



OIL DRAINS



new



18 US Gallon (68 Litre) Waste Oil Drain - Standard Duty

350512 / JOIDR68GD

- 68 litre steel recovery tank
- 8' drainage hose doubles as an oil level sight gauge
- 14" metal collection funnel holds 10 litres of oil
- Shut off valve between funnel and tank allows fluid inspection prior to draining oil
- Uses air to pressurize tank, allowing quick and easy fluid evacuation (maximum 10 PSI)
- Pressure regulator included
- Adjustable bowl height from 46 to 75"
- Uses gravity to drain waste oil from engines, gear boxes and differentials
- Shipping weight: 58 lb (26 kg)



new



17 US Gallon (64 Litre) Low Profile Polypropylene Oil Drain - Standard Duty

350514 / JOIDRLP

- Ideal for draining oil where a pit or hoist is not available
- 17 US Gallon tank with integrated baffle captures oil and minimizes spillage during transport
- Convenient rotary hand pump for fast evacuation to large oil collection tanks
- Large metal screen keeps foreign matter out of recovery tank
- Long steel handle eases moving and positioning of drain
- Shipping Weight: 46 lb (21 kg)



new



15 US Gallon (56 Litre) Low Profile Steel Tank Oil Drain - Standard Duty

350515 / JOIDRLPM

- Ideal for draining oil where a pit or hoist is not available
- 15 US Gallon tank with integrated baffle captures oil and minimizes spillage during transport
- Convenient rotary hand pump for fast evacuation to large oil collection tanks
- Large metal screen keeps foreign matter out of recovery tank
- Long steel handle eases moving and positioning of drain
- Shipping Weight: 46 lb (21 kg)



new



17 US Gallon (64 Litre) Low Profile Polypropylene Antifreeze Drain - Standard Duty

350520 / JOIDRLPAF

- Ideal for draining antifreeze where a pit or hoist is not available
- 17 US Gallon tank with integrated baffle captures antifreeze and minimizes spillage during transport
- Convenient rotary hand pump for fast evacuation to large collection tanks
- Aluminum pump body specifically designed to pump corrosive antifreeze
- Large metal screen keeps foreign matter out of recovery tank
- Long steel handle eases moving and positioning of drain
- Shipping Weight: 46 lb (21 kg)

Drum Wrench - Aluminum Handle

350214 / JADW-1

- Designed to fit perfectly onto most 2" and 3/4" drum plugs
- Made of cast aluminum for strength and safety
- Will not cause sparks
- Hardened and tempered



Drum Dollies

- Heavy gauge steel for professional use
- Powder coated finish
- 5 and 16 gallon models with adjustable clamp bolt
- 16 and 55 gallon models complete with cast iron casters
- Cast iron casters (351005)

PROD. NO.	MOD. NO.	Application	Wheels	Load Limit	Diameter
351003	JDD-5	5 gallon drums	Resin	200 lbs	10-1/4 – 11-1/4"
351004	JDD-16	16 gallon drums	Super Heavy Duty Cast Iron	200 lbs	13-1/2 – 14-1/4"
351005	JDD-55	55 gallon drums	Super Heavy Duty Cast Iron	450 lbs	23"



351003



351004

Cast iron casters



351005

Cast iron casters

Drum Cradle

351011 / JDC-55

- Tilting drum cradle moves, rotates, tips and stores 55 gallon drums with ease
- Self storing lever bar
- Powder coated finish
- Flat packed for easy shipping
- 2-1/2" non-sparking wheels
- Load limit: 600 lb (270 kg)

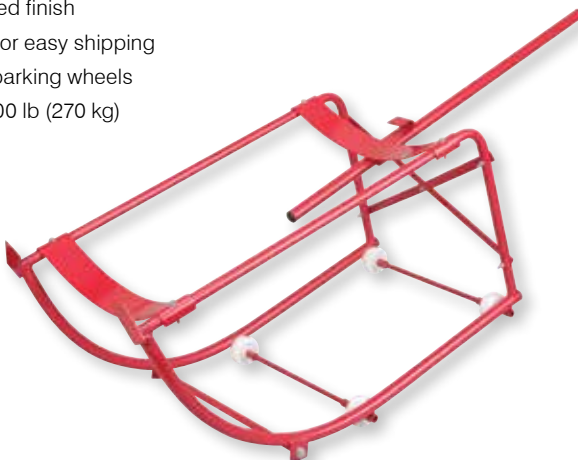



ABRASIVES

Coated Abrasives
Bonded Abrasives
Surface Conditioning Products
Cutting Tools
Wire Products
Diamond Products

AIR TOOLS

Air Drills
Air Grinders
Air Sanders
Impact Wrenches
Spray Guns
Air Line Tools

HAND TOOLS

Shop Equipment
Lubrication &
Fluid Transfer Products
Tool Storage
Specialty Automotive Tools
Machinery

MATERIAL HANDLING

Electric Hoists
Hydraulic / Mechanical Jacks
Manual Hoists & Pullers
Blocks and Sheaves
Trolleys & Clamps
Winches

STRONGARM LIFTING EQUIPMENT

Service / Bottle Jacks
Specialty Truck Equipment
Stands
Cranes - Hydraulic
Rams & Pumps
Shop Presses

Contact your nearest distributor for complete information on the rest of our great product lines.

Check out our other quality JET® products on our website:

www.jetequipment.com