

DMR™



www.daemar.com



O-RINGS



For over 38 years Daemar® Inc. has remained focused on partnering with our customers to deliver fluid sealing solutions that meet their business challenges. Whether the application is a new design or a maintenance requirement, Daemar's global partnerships offer you one of the most complete sources of supply for O-Rings. To ensure that Daemar® consistently meets or exceeds customer requirements, Daemar® is ISO-9001:2008 registered and most suppliers have either TS16949-2000, QS-9000 or ISO-9001:2008 quality registrations.

Daemar® has developed all of the capabilities required to support your lean manufacturing initiatives – providing JIT

delivery, vendor managed inventories and computer systems integration. Supported by the Daemar® regional warehousing network you experience fast, courteous service throughout the world. All of Daemar's locations are fully stocked and staffed with experienced and knowledgeable sales and service professionals. We trust that you will find this catalogue a valuable resource for selecting the appropriate O-Rings for your sealing applications. For further selection assistance, pricing and product availability please contact the Daemar® location nearest you.



Quality - ISO 9002 Certification.....	2
Introduction.....	3
Comparison of Properties Chart.....	4
Temperature & Durometer Charts.....	5
Standard Materials & Specifications.....	6-8
Kalrez®.....	9-13
Metal Detectable O-Rings.....	14
Fluid Compatibility.....	15-22
Design Notes.....	23-24
O-Ring Sizes by AS568 Dash Numbers.....	25-34
O-Ring Sizes - Metric.....	35-39
Back-Up Rings.....	40-46
Quad®- Rings.....	47-49
Metallic O-Rings.....	50-54
O-Ring Kits.....	55
Storage and Shelf Life of Elastomer Compounds.....	56
Identifying O-Ring Failure.....	57-60

ISO-9001:2008 REGISTERED

To consistently meet and exceed our customers' expectations, Daemar® Inc. is ISO-9001: 2008 registered and most of our suppliers are QS-9000 and/or ISO-9000 quality registered.



DMRTM
ISO 9001:2008
Registered QMS

O-RINGS

The O-ring is the most widely used seal in industry today. It is simple in concept, easy to install, can be used as a double-acting seal, can seal pressures to over 5,000psi in static and dynamic applications and, best of all, is very economical.

While simple in concept, it can be very sophisticated in its applications. This catalogue is intended to give just a brief overview of O-ring design and selection. When information beyond the scope of this catalogue is required, please visit our website or contact a Daemar technical service representative.

How to specify an O-ring

O-rings are specified by calling out (1) the O-ring size (inside diameter and cross section), (2) the compound and (3) the hardness.

Identifying the correct size:

O-rings are available in 349 standard inch sizes as set up by the Aerospace Standard 568 published by the society of Automotive Engineers. These sizes are designated by dash numbers as shown in the sizing tables on pages 23 to 31. For O-ring sizes other than these standard AS sizes, specify the actual dimensions desired for the inside diameter (I.D.) and the cross section (W). Measurements can be made with calipers or with one of several o-ring measurement tools (sizing chart, measurement cone). Our standard metric o-ring sizes are listed on pages 33 to 37 and standard Boss sizes on page 32.

Selecting a compound:

- i) Check compatibility with the fluid media to be sealed (see tables pages 13 to 20)
- ii) Identify the operating temperature range required (see material specifications on pages 6 to 8)
- iii) Identify other general properties that are required for the application, check these properties against the performance of various compounds in the comparison of properties table on page 4.

Determining Hardness:

Now that a base compound has been selected the next step is to determine the durometer (hardness) that is needed for the application. The Durometer chart (page 5) identifies the correct level of hardness for the corresponding fluid pressure and maximum extrusion gap.

The chart matches the general rubber properties required in most O-ring applications with the capabilities of commonly used elastomers. Since no one elastomer is rated “excellent” for all properties, compromises are sometimes necessary when selecting an elastomer for a specific O-ring application. Start with the most critical properties to narrow your choices.

Property	Nitrile	SBR	Neoprene®	Ethylene Propylene	Fluorocarbon	Fluorosilicone	Polyacrylate	Polyurethane	Silicone	Kalrez®
Ozone resistance	P	P	GE	E	E	E	E	E	E	E
Weather Resistance	F	F	E	E	E	E	E	E	E	E
Heat Resistance	G	FG	G	E	E	E	E	E	E	E
Chemical Resistance	FG	FG	FG	E	E	E	P	F	GE	E
Oil Resistance	E	P	FG	P	E	G	E	G	PG	E
Impermeability	G	F	G	G	G	P	E	G	P	E*
Cold Resistance	G	G	FG	GE	FP	GE	P	G	E	FP
Tear Resistance	FG	FG	FG	GE	F	P	FG	GE	P	F
Abrasion Resistance	G	G	G	GE	G	P	G	E	P	G
Set Resistance	GE	G	F	GE	GE	GE	F	F	GE	GE
Dynamic Properties	GE	G	F	GE	GE	P	F	E	P	GE
Acid Resistance	F	F	FG	G	E	FG	P	P	FG	GE
Tensile Strength	GE	GE	G	GE	GE	F	F	E	P	GE
Electrical Properties	F	G	F	G	F	E	F	FG	E	F
Water/Steam Resistance	FG	FG	F	E	FG	F	P	P	F	GE
Flame Resistance	P	P	G	P	E	G	P	P	F	F

E = Excellent

G = Good

F = Fair

P = Poor

E* = Special Compounds Available

TEMPERATURE RANGE CHART

The temperature range for any compound is determined by the base elastomer used. This chart depicts the maximum temperature range for each elastomer. The temperature range for a specific compound may not reach these maximum limits. Higher temperatures may be considered if exposure is short term or intermittent.

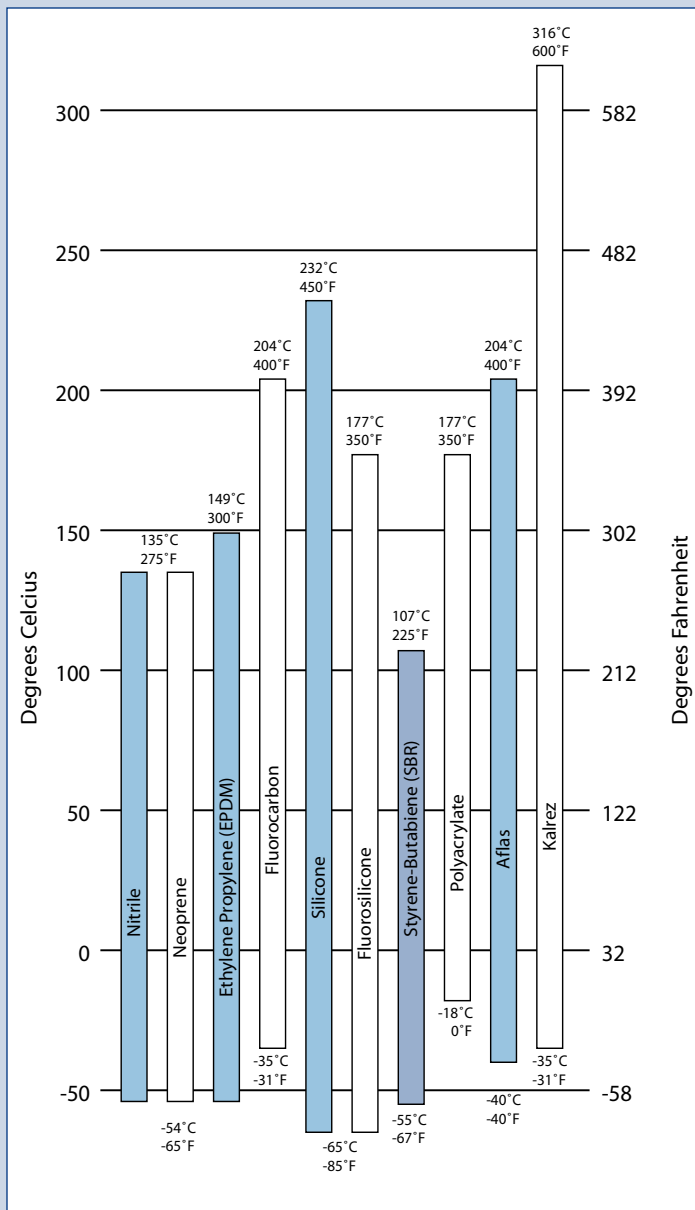

DUROMETER CHART

The hardness of rubber compounds is commonly measured by the Shore 'A' durometer; the higher the durometer number, the harder the compound. 70-durometer hardness should be used wherever possible as it offers the best combination of properties for most O-Ring applications. Softer compounds stretch easier and seal better on rough surfaces. Harder compounds offer greater abrasion resistance and resistance to extrusion. Extrusion must always be considered where high pressures are used. The proper hardness may be selected from this chart by matching the fluid pressure with the maximum extrusion gap.

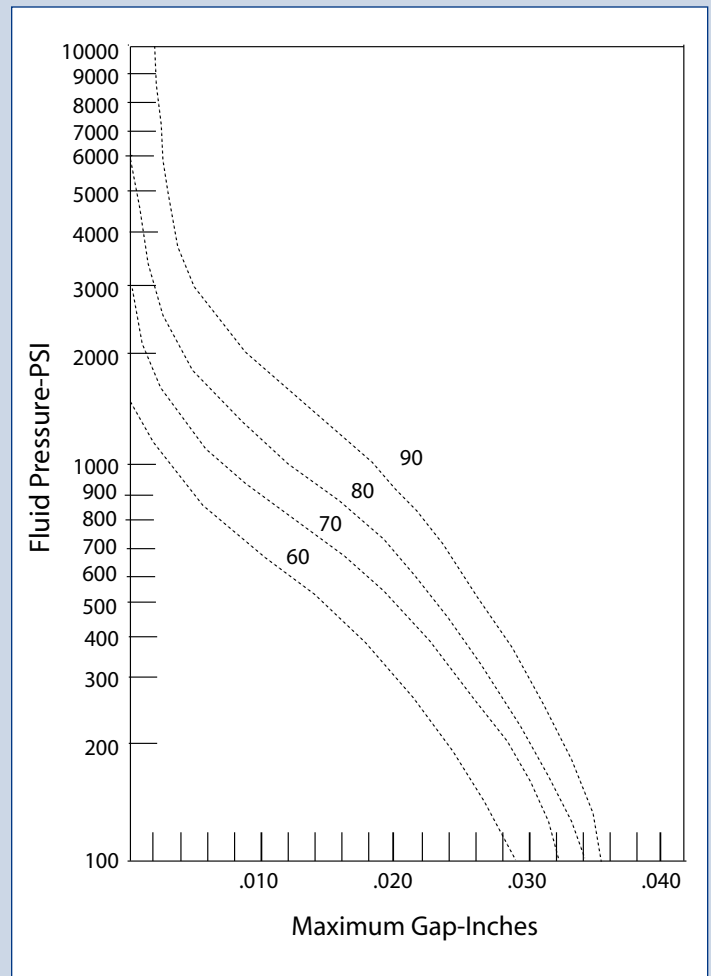

NITRILE BUTADIENE/BUNA'N' (NBR)

This compound has excellent resistance to a wide variety of fluids, good tensile strength, high elongation, low compression set, and excellent resistance to abrasion and tear. Most O-Rings are made of this material due to its good physical and mechanical properties.

Nitrile is not recommended for exposure to di-ester, silicate ester, phosphate ester, hydraulic fluids, automotive brake fluid, acetates, ketones, aromatic fluids, ozone, sunlight, and weather. Good gasoline resistance, heat and abrasion resistance.

Trade Name:	Chemigum[®], NySyn, Hycar[®], Paracril[®], Krynac[®]
Temperature Range:	-65° F to 250° F
Usual Colour:	Black
Usual hardness Range:	50-90 Shore A

SILICONE (SI)

This compound has excellent resistance to temperature extremes and excellent dry heat resistance. It has good resistance to sunlight, ozone, weathering, and has moderate oil resistance.

Silicone is not recommended for exposure to petroleum fluids, and ketones. It is also not recommended where physical strength or abrasion resistance is required, since it has poor tensile and tear strength.

Trade Name:	Silastic[®], Thermoflex[™]
Temperature Range:	-80° F to 450° F
Usual Colour:	Red, Blue, Yellow
Usual hardness Range:	50-90 Shore A

FLUOROCARBON (FKM, FMC)

This compound has excellent resistance to a wide range of chemicals, excellent high temperature stability, excellent resistance to petroleum products, good resistance to weathering, ozone, oxygen, high temperature and flame, low compression set, low gas permeability, and is good for hard vacuum service. Fluorocarbon is not recommended for exposure to ketones, esters, anhydrous ammonia, and fire resistant fluids such as Skydrol, hot hydrofluoric, chlorosulonic acid, hot water/steam, and/or brake fluid.

Trade Name:	Viton[®], Fluorel[®]
Temperature Range:	-31° F to 437° F
Usual Colour:	Black, Brown, Green
Usual hardness Range:	60-95 Shore A

HYDROGENATED ACRYLONITRILE BUTADIENE (HNBR, HSN)

Hydrogenated Acrylonitrile Butadiene (HNBR), also known as Highly Saturated Nitrile (HSN) is superior to NBR in low brittle temperature, heat, oil, oil additive and sour oil resistance, and is far more resistant to sour gasoline and ozone than NBR.

Trade Name:	Therban[®], Zetpol[®], Tornac
Temperature Range:	-40° F to 300° F
Usual Colour:	Green, Black
Usual hardness Range:	60-80 Shore A

HNBR is ideal for industrial products normally made of NBR, and can be used in more severe conditions with much longer service life. This compound is extensively used in R-134A cooling systems. HNBR is not recommended for exposure to ketones, esters, ethers, and aromatic fluids.

CHLOROPRENE (CR)

This compound has excellent resistance to refrigerants, ozone, oxygen, sunlight, and weathering, good resistance to heat and flame, fair resistance to oil, resists flexing and stain, and has low compression set.

Chloroprene is not recommended for exposure to water, phosphate, esters, aromatic hydrocarbons, chlorinated solvents, and ketones. Good resistance to cold and voltage, applied to general commodities.

Trade Name:	Neoprene®
Temperature Range:	-65° F to 275° F
Usual Colour:	Black
Usual hardness Range:	50-90 Shore A

ETHYLENE PROPYLENE (EPDM)

This compound has high tensile strength, elongation, good low temperature flexibility, outstanding heat aging, good electrical properties, excellent resistance to water, steam, acids, alkalis, ketones, Skydrol, phosphate, oxygen, weathering, ozone, and brake fluid.

Ethylene propylene is not recommended for exposure to petroleum oils and solvents, and di-ester base lubricants.

Good brake oil resistance, excellent heat resistance.

Trade Name:	Vistalon®, Epsyn®, Fpcar, Royalene®, Nordel®
Temperature Range:	-80° F to 300° F
Usual Colour:	Red, Blue, Yellow
Usual hardness Range:	50-90 Shore A

STYRENE BUTADIENE/BUNA'S' (SBR)

This compound is a low cost and high volume rubber; it can be compounded into materials with high tensile strength, high modulus, and high hardness without the use of large amount of fillers; it has good abrasion resistance, and when it is a low styrene and high butadiene compound, it has good flexibility at low temperature.

Styrene butadiene is not recommended for exposure to solvents, oils, dieter lubricants, and aromatic hydrocarbons.

Trade Name:	GRS
Temperature Range:	-40° F to 212° F
Usual Colour:	Black
Usual hardness Range:	70-90 Shore A

FLUROSILICONE (FSI, FVMQ)

This compound has the general characteristics for silicone, with excellent resistance to petroleum oils, solvent, hydrocarbon fuels, ozone, and weathering; it also has good low temperature flexibility, low compression set and good electrical properties.

Trade Name:	Silastic® LS, FSE
Temperature Range:	-85° F to 350° F
Usual Colour:	Light blue
Usual hardness Range:	50-90 Shore A

PERFLUOROELASTOMERS (FFKM)

This product is available in standard AS568 sizes, metric sizes as well as custom molds and extrusions. Providing flexibility, chemical resistance, and High Temperature characteristics this is the Material of Choice for Critical Sealing applications.

Trade Name:	Kalrez®
Temperature Range:	-31° F to 600° F
Usual Colour:	Black
Usual hardness Range:	75 Shore A

TFE ELASTOMER

This compound provides an advantageous combination of high temperature, chemical and electrical resistance properties. It is different from fluoroelastomers such as FKM (FPM) types because of its unique composition (tetrafluoroethylene/propylene copolymer). As a result, TFE Elastomers can provide service advantages in many chemicals, as well as in electrical applications.

Trade Name:	Aflas™
Temperature Range:	-40°F to 400°F
Usual Colour:	Red, Blue, Yellow, Black
Usual hardness Range:	50-90 Shore A

POLYURETHANE (AU, EU)

Polyurethane elastomers, as a class, have excellent wear resistance, high tensile strength and high elasticity in comparison with any other elastomers. Permeability is good and comparable with butyl. The inherent toughness and abrasion resistance of polyurethane seals is particularly desirable in hydraulic systems where high pressure, shock loads, wide metal tolerances, or abrasive contamination is anticipated.

Trade Name:	Vibrathane™, Cyanaprene, Polathane, Adiprene, Disogrin, Elastothane, Formez, Pellethane
Temperature Range:	-60°F to 200°F
Usual Colour:	Amber
Usual hardness Range:	70 and 90 Shore A

THE SEAL TO TRUST FOR TOUGH SEALING APPLICATIONS

For demanding sealing applications when customers require the very best, Kalrez® parts manufactured only by DuPont Performance Elastomers, are the elastomer seals of choice. Supplied in standard O-rings or custom shapes, Kalrez® resists over 1,800 different chemicals while offering the high temperature stability of PTFE (327°C). Advanced properties help maintain seal integrity, reduce maintenance and operating costs and improve safety. Kalrez® parts provide reliable, long-term service with a wide range of aggressive industrial and electronic grade chemicals. It is used in highly aggressive chemical processing, semiconductor wafer processing, pharmaceutical, oil and gas recovery, aerospace and petroleum applications. Production facilities for Kalrez® are ISO 9000 and AS 9100 registered.

INDUSTRIES

For over 25 years, Kalrez® perfluoroelastomer parts have been providing the ultimate in sealing performance in the harshest processing environments. Some of the industries and applications in which Kalrez® parts provide superior performance include:

Chemical Processing - In pumps, valves, reactors, flange joints and other equipment, Kalrez® parts—whether O-rings, custom shapes or valve stem packing systems—are proving their value year in and year out as the best choice for long-term, reliable service.

Semiconductor - The success of Kalrez® has been field-proven in the manufacture of semiconductors, where processing steps can involve extremes of both thermal and chemical exposure.

Food and Pharmaceuticals - Food and Pharmaceutical applications require the ultimate in cleanliness and Kalrez® parts provide that along with excellent sealing performance in a wide range of aggressive media over a broad range of temperatures. The introduction of FDA-compliant Kalrez® compounds offers a new standard of sealing solutions with full traceability, low contamination from extractables and excellent seal life.

Aerospace - High-performance Kalrez® parts provide reliable and long-lasting sealing performance for the military, commercial and general aviation industry. They are used as oil seals in gas turbine engines and air delivery systems.

Oil and Gas - Kalrez® parts stand up to severe down-hole conditions—from high pressures and temperatures, to aggressive sour gas and corrosive fluids.

Whether you are in the chemical processing industry, oil and gas, wafer processing or thousands of other demanding applications, Kalrez® seals can extend your mean time between failures and reduce your risk of seal failure.

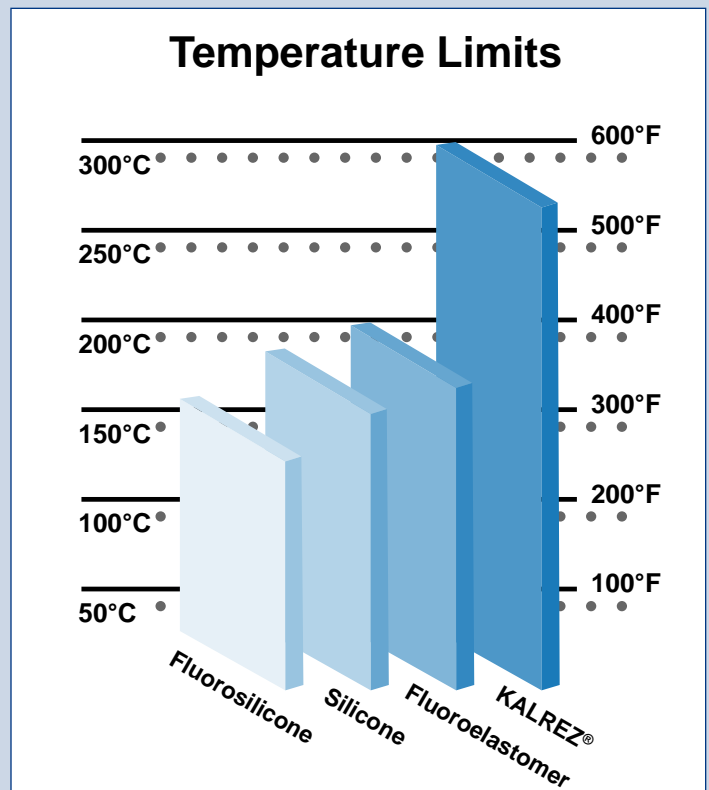

SUPERIOR CHEMICAL RESISTANCE TO MORE THAN 1800 CHEMICALS

Kalrez® perfluoroelastomer parts have virtually universal chemical resistance. They withstand attack from more than 1,800 chemicals, solvents and plasmas. Standardizing on Kalrez® products for broad chemical resistance reduces your need to keep multiple materials on the shelf, thus lowering cost of inventory.

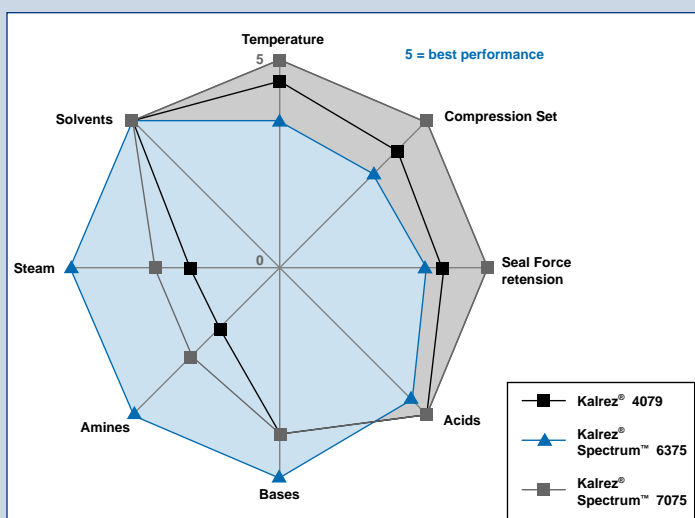

PHYSICAL PROPERTIES AND COMPOUND COMPARISONS

Kalrez® perfluoroelastomer parts are available in a number of different compounds that are formulated to optimize properties and give the best possible performance in various applications. Modification of the finished properties is achieved by use of fillers and other additives. The table on page 13 summarizes the basic physical properties of the most commonly used compounds. Descriptions of the key attributes of each compound and their general areas of application follow.

STANDARD COMPOUNDS

Compound 6375 - A carbon black-filled compound for general use in O-rings, seals, diaphragms and other parts specifically for the chemical process industry. This compound has excellent, broad chemical resistance, good mechanical properties, and outstanding hot-air aging properties. 6375 is well suited for use in mixed process streams because of its excellent resistance to acids, bases, and amines. In addition, it is the suggested compound for use in hot water, steam, ethylene oxide and propylene oxide. A maximum continuous service temperature of 275°C [525°F] is recommended.

Compound 7075 - Kalrez® Spectrum™ 7075 broadens Kalrez® sealing options with a perfluoroelastomer that has enhanced physical performance properties including very low compression set (12% pellets/15% O-rings per ASTM D 395B) and improved seal force retention. It is a carbon black filled compound utilizing new and proprietary cure chemistry technology with mechanical properties designed for improving sealing performance in both high temperature environments and temperature cycling situations. 7075 joins the family of Kalrez® Spectrum™ products designed for the chemical processing industry. To provide even greater sealing performance in dynamic applications where low friction is required, 7075 O-rings have a glossier finish than other Kalrez® parts. 7075 was specifically developed to be used as an O-ring or custom-sealing component in the chemical and hydrocarbon industries, with an improved thermal resistance that extends maximum service temperature to 327°C (620°F). Kalrez® Spectrum™ 7075 offers the enhanced elastomeric properties outlined above while providing a chemical resistance better than the industry standard set by Kalrez® 4079.

Compound 4079 - A low compression set compound for general-purpose use in O-rings, diaphragms, seals, and other parts used in the process and aircraft industries. It is a carbon black-filled compound with excellent chemical resistance, good mechanical properties, and outstanding hot air aging properties. It exhibits low swell in organic and inorganic acids and aldehydes and has good response to temperature cycling effects. A maximum operating temperature of 316°C [600°F] is recommended, with short excursions to higher temperatures possible. This compound is not recommended for use in hot water/steam applications or in contact with certain hot aliphatic amines, ethylene oxide, or propylene oxide.

SPECIALTY COMPOUNDS

Note: Before ordering Kalrez® parts in specialty compounds, please consult with DuPont Dow Elastomers or Distributor Technical Staff to determine properties needed for the application. Specialty compound products are generally not held in inventory.

Compound 1050LF - A general-purpose compound for O-rings, seals, and other parts used in chemical process industries. It has good hot water/steam, and excellent amine resistance. Maximum recommended service temperature of 288°C [550°F]. Not recommended for use in organic or inorganic acids at high temperatures.

Compound 1058 - A carbon black-filled compound that has been plasticized with a perfluorinated oil. It is the softest, lowest modulus compound available. Generally, it is similar in chemical resistance to Compound 1050LF; it has an upper service temperature of 260°C [500°F]. Typically used in applications that require low sealing force or high extensibility including liquid chromatography septa, seals/seats for relief valves and tubing. Its shrinkage is greater than other Kalrez compounds; therefore, finished parts may differ from standard specifications.

Compound 3018 - A carbon black-filled compound similar to Compound 1050LF, except for higher hardness/modulus. This compound is good in hot water/steam and offers the best high pressure extrusion resistance. Generally used in oil field and process industry applications where these properties coupled with good amine and general chemical resistance are required. A maximum service temperature of 288°C [550°F] is recommended.

Compound 2037 - A non-black-filled compound that is well suited for selected applications in the semiconductor and other markets that demand high purity elastomers. Compound 2037 has excellent chemical resistance exhibiting low swell in organic acids, inorganic acids, esters, ketones, and aldehydes. It also offers good mechanical properties. A maximum service temperature of 218°C [425°F] is recommended.

Compound 6380 - Specifically developed to extend service lifetime in chemical and hydrocarbon processes involving hot, aggressive amines, strong acids and oxidizing media. Offering excellent overall chemical resistance and mechanical properties for static and dynamic sealing applications in harsh chemical plant processes at temperatures up to 225°C. Compound 6380 exhibited very low swell after 672 hours exposure to ethylene diamine, ethanolamine and ammonium hydroxide, compared to alternative perfluoroelastomer parts commonly specified for such environments. Manufactured in an easily identifiable cream colour.

Compound 9100 - An amber translucent compound targeted specifically for deposition process applications, i.e., HDPCVD, PECVD, SACVD, Metal CVD, ALD, etc. It also exhibits excellent performance in “select” etching and ashing/stripping process applications. Specifically designed for low erosion and ultra-low particle generation in harsh plasma environments. It offers outstanding thermal stability, very low outgassing as well as excellent elastic recovery and mechanical strength properties and is well suited for both static and dynamic sealing applications. A maximum continuous service temperature of 300°C is suggested. Ultrapure post-cleaning and packaging is standard for all parts made from compound 9100.

CHEMICAL RESISTANCE

Because Kalrez® has outstanding chemical resistance, it withstands nearly all classes of chemicals. With this combination of high thermal stability and excellent chemical resistance, the Kalrez® perfluoroelastomer parts rating may be conservative, as actual field experience and the example above have demonstrated.

In comparing the chemical and fluid resistance of Kalrez® perfluoroelastomers to that of Teflon® fluoropolymer resins, certain differences should be kept in mind:

- Kalrez® is an amorphous low-modulus rubber whereas Teflon® is a crystalline high-modulus plastic. In fluid environments where high permeation occurs, Kalrez® will probably swell to a greater extent than Teflon®, even though the polymer is not chemically attacked. Environments in

which this is most noticeable are fully halogenated solvents, Freon®, and Freon® alternatives. Service ability of Kalrez® in these environments will be dependent upon the specifics of the application.

- As with all elastomers, it is necessary to compound Kalrez® perfluoroelastomers with fillers and curatives to gain desired mechanical properties for functionality. In a limited number of environments, even though the polymer is stable, the fillers and curative systems may interact with the chemicals. However, because the level of fillers in Kalrez® perfluoroelastomers is much lower than in most other elastomers, such filler interactions are generally negligible with Kalrez® parts. Where such interactions can occur, such as in highly oxidative environments, service performance is dependent on the conditions of the application and may be affected by compound choice.

TYPICAL PHYSICAL PROPERTIES (1)

Compounds	Standard			Specialty			
	6375	7075	4079	1050LF	1058	3018	2037
Durometer Hardness (2),							
Shore A, points +/- 5	75	75	75	82	65	91	79
100% Modulus (3)							
psi	1050	1100	1050	1800	675	2450	900
MPa	7.2	7.6	7.2	12.4	4.7	16.9	6.2
Tensile Strength at Break (3)							
psi	2200	2600	2450	2700	1300	3150	2450
MPa	15.1	17.9	16.5	18.6	9.0	21.7	16.9
Elongation at Break (3), %	160	160	150	125	180	125	200
Compression Set (4), %							
70 hours at 204 °C (400 °F)	30	12	25	35	40	35	27
Brittle Point (5),							
°C	-	-	-50	-41	-40	-37	-54
°F	-	-	-58	-42	-41	-35	-65

(1) Not to be used for specifications (2) ASTM D2240 (3) ASTM D412, 500 mm/min (20 in/min) (4) ASTM D395B pellets (5) ASTM D746

Because each application is unique, it is recommended that users of Kalrez® perfluoroelastomer parts always conduct their own evaluations to determine the suitability of Kalrez® for their application. Because of laboratory constraints and differences in field applications, the results shown in this technical information may be based on conditions that may not necessarily reflect actual operating environments for a specific application. Additionally, many elastomeric materials may show excellent chemical resistance to pure reagents in relatively short-term laboratory tests. However, they may fail in actual service because of chemical attack by additives and/or impurities. Kalrez® perfluoro-elastomer parts, with their near-universal chemical resistance, provide an extra degree of safety against these unknown corrosive influences. Case histories are available from Daemar detailing proven performance of Kalrez® parts in over 100 specific chemical applications. Information on test performance in a limited number of specific chemicals is also available through your authorized Kalrez® distributor.

CAUTION

Kalrez® perfluoroelastomer parts, like all fluorinated products, should not be exposed to molten or gaseous alkali metals, such as sodium and potassium, because a highly exothermic reaction may occur. At elevated temperatures above 100°C (212°F), service life may be significantly reduced in fluids containing high concentrations of some diamines, nitric acid, and basic phenols. Kalrez® parts should always be tested for suitability.

FOOD AND PHARMACEUTICAL INDUSTRY SEALS

As a result of excessive use, shearing and damage can occur to equipment causing undetectable product contamination. Metal detectables can eliminate product recall, lower product loss and decrease the risk of elastomers consumed in finished product.

System Protection with Metal Detectable O-Rings

A common problem with component and filler parts is excessive wear and tear. When rubber breaks off a moving part it can migrate through your system and into your product. Searching for and locating fragmented rubber parts is a costly, time consuming and inconclusive process requiring expensive x-ray equipment, manual observation and an extensive maintenance program. Not locating a worn and lost rubber piece can have an even costlier outcome. By manufacturing a standard elastomer with a metal impregnated compound, displaced rubber material can now be located by an in-line metal detector. This alarm enables your system to instantly reject contaminated product.

Benefits of Metal Detectable O-Rings include:

- Easily detect lost elastomeric fragments.
- Prevent product recall.
- Lower product loss.
- Stop distribution of contaminated product.
- For use in standard OEM equipment.
- Designed for microbial, high-temperature and mechanical applications.
- Available in hygienic seals, screens, sheets, extrusions, valve stems and filler boots.

Typical Applications:

- Food
- Beverage
- Pharmaceutical

Detectable O-Ring Materials:

- Buna
- EPDM
- FKM
- Silicone
- Tuf-Steel™

Meets Industry Standards:

- Elastomers meet Title 21 CFR 177.2600
- Tuf-Steel meets Title 21 CFR 177.1550
- Meets USDA Hazard Analysis and Critical Control points.
- Detectable metal additive meets the latest revision of the Food Chemicals Codex *
- Animal Derived Ingredient Free†

** The Food Chemicals Codex Project is an activity of the food and nutrition board of the Institute of Medicine and is supported by the U.S. Food and Drug Administration.*

™ Tuf-Steel and ADI Free are trademarks of Rubber Fab Technologies Group.

† Buna is not an ADI Free elastomer

Please Contact a Daemar Customer Service Representative for all your inquiries. Or visit our website www.daemar.com.

Fluid	Nitrile	EPDM	Viton®	Neoprene	Silicone	Kalrez®
Acetaldehyde	3	2	4	3	2	1
Acetamide	1	1	3	1	2	1
Acetic Acid, 5%	2	1	1	1	1	1
Acetic Anhydride	4	2	4	2	2	1
Acetone	4	1	4	4	4	1
Acetyl Acetone	4	1	4	4	4	1
Acetyl Chloride	4	4	1	4	3	1*
Acetylene	1	1	1	2	2	1
Acetylene Tetrabromide	4	1	1	2	X	1
Acrylonitrile	4	4	3	4	4	1*
Air, Below 200° F	2	1	1	1	1	1
Air, 200 - 300° F	3	2	1	2	1	1
Air, 300 - 400° F	4	4	1	4	1	1
Aluminum Acetate	2	1	4	2	4	1
Aluminum Bromide	1	1	1	1	1	1
Aluminum Chloride	1	1	1	1	2	1
Aluminum Fluoride	1	1	1	1	2	1
Aluminum Nitrate	1	1	1	1	2	1
Aluminum Salts	1	1	1	1	1	1
Aluminum Sulphate	1	1	1	1	1	1
Amines-Mixed	4	2	4	2	2	1*
Ammonia, Gas, Cold	1	1	4	1	1	1
Ammonia, Gas, Hot	4	2	4	2	X	1*
Ammonia, Liquid (Anhydrous)	2	1	4	1	2	1*
Ammonium Hydroxide	4	1	4	1	1	1*
Ammonium Nitrite	1	1	X	1	2	1
Ammonium Persulfate Solution	4	1	X	X	X	1
Ammonium Persulfate 10%	4	1	X	1	X	1
Ammonium Phosphate,	1	1	4	1	1	1
Ammonium Salts	1	1	3	1	1	1
Ammonium Sulphate	1	1	4	1	X	1

Fluid	Nitrile	EPDM	Viton®	Neoprene	Silicone	Kalrez®
Ammonium Sulfide	1	1	4	1	X	1
Amyl Acetate	4	3	4	4	4	1
Amyl Alcohol	2	1	2	2		1
Amyl Borate	1	4	1	1	X	1
Amyl Chloride	X	4	1	4	4	1
Amyl Chloronaphthalene	4	4	1	4	4	1
Amyl Naphthalene	4	4	1	4	4	1
Anhydrous Ammonia	2	1	4	1	2	1
Anhydrous Hydrazine	4	2	4	2	X	1
Anhydrous Hydrogen Fluoride	4	1	4	X	X	1
Aniline	4	2	3	4	4	1
Aniline Dyes	4	2	2	2	3	1
Aniline Hydrochloride	2	2	2	4	3	1
Aniline Oil	4	2	3	4	4	1
Animal Oil (Lard Oil)	1	2	1	2	2	1
Argon	1	1	1	1	1	1
Aromatic Fuel -50%	2	4	1	4	4	1
Arsenic Acid	1	1	1	1	1	1
Asphalt	2	4	1	2	4	1
ASTM Oil, No.1	1	4	1	1	1	1
ASTM Oil, No.2	1	4	1	2	4	1
ASTM Oil, No.3	1	4	1	4	3	1
ASTM Oil, No.4	2	4	1	4	4	1
ASTM Reference Fuel C	2	4	1	4	4	1
Automatic Transmission Fluid	1	4	1	2	4	1
Automotive Brake Fluid	3	1	4	2	3	1
Barium Chloride	1	1	1	1	1	1
Barium Hydroxide	1	1	1	1	1	1
Barium Salts	1	1	1	1	1	1
Barium Sulfide	1	1	1	1	1	1
Beer	1	1	1	1	1	1

1 = Satisfactory 2 = Fair 3 = Marginal 4 = Unsatisfactory X = Consult Factory (Insufficient Data)
 * indicates that differences may exist between KALREZ® compounds in certain applications

Fluid	Nitrile	EPDM	Viton®	Neoprene	Silicone	Kalrez®
Beet Sugar Liquors	1	1	1	2	1	1
Benzaldehyde	4	1	4	4	2	1*
Benzene	4	4	1	4	4	1
Benzochloride	4	1	1	4	X	1
Benzoic Acid	4	4	1	4	4	1*
Benzyl Alcohol	4	2	1	2	2	1
Benzyl Benzoate	4	4	1	4	4	1
Benzyl Chloride	4	4	1	4	4	1
Bleach Liquor	3	1	1	2	2	1
Borax	2	1	1	4	2	1
Boric Acid	1	1	1	1	1	1
Bromine	4	4	1	4	4	1
Bromine Pentafluoride	4	4	4	4	4	2*
Bromine Trifluoride	4	4	4	4	4	2*
Bromine Water	4	2	1	4	4	1*
Bunker Oil	1	4	1	4	2	1
Butane	1	4	1	1	4	1
Butane, 2,2-Dimethyl	1	4	1	2	4	1
Butane, 2,3-Dimethyl	1	4	1	2	4	1
Butanol (Butyl Alcohol)	1	2	1	1	2	1
Butter-Animal Fat	1	1	1	2	2	1
N-Butyl Acetate	4	2	4	4	4	1
Butyl Acetyl Ricinoleate	2	1	1	2	X	1
Butyl Acrylate	4	4	4	4	X	1
Butyl Alcohol	1	2	1	1	2	1
Butyl Amine or N-Butyl Amine	3	3	4	4	4	1*
Calcine Liquors	1	1	1	X	X	1
Calcium Acetate	2	1	4	2	4	2
Calcium Bisulfite	2	1	2	2	3	1
Calcium Carbonate	1	1	1	1	1	1
Calcium Chloride	1	1	1	1	1	1

Fluid	Nitrile	EPDM	Viton®	Neoprene	Silicone	Kalrez®
Calcium Cyanide	1	1	X	1	1	1
Calcium Hydroxide	1	1	1	1	1	1
Calcium Hypochlorite	2	1	1	2	2	1
Calcium Nitrate	1	1	1	1	2	1
Calcium Phosphate	1	1	1	2	1	1
Calcium Salts	1	1	1	1	2	1
Calcium Silicate	1	1	1	1	X	1
Calcium Sulfide	1	1	1	1	1	1
Calcium Sulfite	1	1	1	1	1	1
Calcium Thiosulfate	2	1	1	1	1	1
Cane Sugar Liquors	1	1	1	1	1	1
Caproic Aldehyde	X	2	4	X	2	1
Carbitol	2	2	2	2	2	1
Carbolic Acid Phenol	4	2	1	4	4	1*
Carbon Bisulfide	4	4	1	4	4	1
Carbon Dioxide	1	1	1	1	1	1
Carbon Disulfide	4	4	1	4	4	1
Carbon Monoxide	1	1	1	2	1	1
Carbon Tetrachloride	2	4	1	4	4	1*
Carbonic Acid	2	1	1	1	1	1
Castor Oil	1	2	1	1	1	1
Cellosolve	4	2	4	4	4	1
Cellosolve Acetate	4	2	4	4	4	1
Cellosolve, Butyl	4	2	4	4	4	1
Celluguard	1	1	1	1	1	1
China Wood Oil (Tung Oil)	1	4	1	2	4	1
Chloroacetic Acid	4	2	4	4	X	1
Chlordane	2	4	1	3	4	1
Chlorextol	2	4	1	2	4	1
Chlorinated Solvents, Dry	4	4	1	4	4	1
Chlorinated Solvents, Wet	4	4	1	4	4	1

1 = Satisfactory 2 = Fair 3 = Marginal 4 = Unsatisfactory X = Consult Factory (Insufficient Data)
 * indicates that differences may exist between KALREZ® compounds in certain applications

Fluid	Nitrile	EPDM	Viton®	Neoprene	Silicone	Kalrez®
Chlorine, Dry	4	X	2	2	4	1
Chlorine, Wet	4	X	2	4	4	2*
Chlorine Dioxide	4	3	1	4	X	1*
Chlorine Trifluoride	4	4	4	4	4	2*
Chloroacetone	4	1	4	4	4	1
Chlorobenzene	4	4	1	4	4	1
Chloroform	4	4	1	4	4	1
Chlorosulphonic Acid	4	4	4	4	4	1
Chlorotoluene	4	4	1	4	4	1
Citric Acid	1	1	1	1	1	1
Cobalt Chloride	1	1	1	1	2	1
Cod Liver Oil	1	1	1	2	2	1
Coffee	1	1	1	1	1	1
Coke Oven Gas	4	4	1	4	2	1
Coliche Liquors	2	2	X	1	X	1
Copper Acetate	2	1	4	2	4	1
Copper Chloride	1	1	1	2	1	1
Copper Cyanide	1	1	1	1	1	1
Copper Salts	1	1	1	1	1	1
Copper Sulfate	1	1	1	1	1	1
Copper Sulfate 10%	1	1	1	1	1	1
Copper Sulfate 50%	1	1	1	1	1	1
Corn Oil	1	3	1	3	1	1
Cottonseed Oil	1	3	1	3	1	1
Creosote, Coal Tar	1	4	1	2	4	1
Creosote, Wood	1	4	1	2	4	1
Cresylic Acid	4	4	1	4	4	1
Crude Oil	2	4	1	4	4	1
Cutting Oil	1	4	1	2	4	1
Cyclohexane	1	4	1	3	4	1
Cyclohexanol	1	4	1	2	4	1

Fluid	Nitrile	EPDM	Viton®	Neoprene	Silicone	Kalrez®
Cyclohexanone	4	2	4	4	4	4
Denatured Alcohol	1	1	1	1		1
Detergent, Water Solution	1	1	1	2	1	1
Developing Fluids (Photo)	1	2	1	1	1	1
Dexron	1	4	1	2	4	1
Diacetone	4	1	4	4	4	1
Diacetone Alcohol	4	1	4	2	4	1
Diazinon	3	4	2	3	4	1
Dibenzyl Ether	4	2	4	4	X	1
Dibenzyl Sebacate	4	2	2	4	3	1
Dibromoethyl Benzene	4	4	1	4	4	1
Dibutylamine	4	4	4	3	3	1
Dibutyl Ether	4	3	3	4	4	1
Dibutyl Phthalate	4	2	3	4	2	1
Dichloro-Butane	2	4	1	4	4	1
Dichloro-Isopropyl Ether	4	3	3	4	4	1
Diesel Oil	1	4	1	3	4	1
Di-ester Lubricant MIL-L-7808	2	4	1	4	4	1
Di-ester Synthetic Lubricants	2	4	1	4	4	1
Diethylamine	2	2	4	2	2	1*
Diethyl Ether	4	4	4	3	4	1
Diethylene Glycol	1	1	1	1	2	1
Dimethyl Phthalate	4	2	2	4	X	1
Dioxane	4	2	4	4	4	1
Dioxolane	4	2	4	4	4	1
Dipentene	2	4	1	4	4	1
Diphenyl	4	4	1	4	4	1
Diphenyl Oxides	4	4	1	4	3	1
Dowtherm, A	4	4	1	4	4	1
Drinking Water	1	1	1	2	1	1
Dry Cleaning Fluids	3	4	1	4	4	1

1 = Satisfactory 2 = Fair 3 = Marginal 4 = Unsatisfactory X = Consult Factory (Insufficient Data)
 * indicates that differences may exist between KALREZ® compounds in certain applications

Fluid	Nitrile	EPDM	Viton®	Neoprene	Silicone	Kalrez®
Epichlorohydrin	4	2	4	4	4	1
Epoxy Resins	X	1	4	1	X	1
Ethane	1	4	1	2	4	1
Ethanol	3	1	3	1		1
Ethanol Amine	2	2	4	2	2	1
Ethers	4	3	3	4	4	1
Ethyl Acetate-Organic ester	4	2	4	4	2	1
Ethyl Acetoacetate	4	2	4	4	2	1
Ethyl Acrylate	4	2	4	4	2	1
Ethylacrylic Acid	4	2	X	2	4	1
Ethyl Alcohol	3	1	3	1		1
Ethyl Benzene	4	4	1	4	4	1
Ethyl Benzoate	4	4	1	4	4	1
Ethyl Bromide	2	4	1	4	X	1
Ethyl Cellosolve	4	2	4	4	4	1
Ethyl Cellulose	2	2	4	2	2	1
Ethyl Chloride	1	3	1	4	4	1
Ethyl Chlorocarbonate	4	2	1	4	4	1
Ethyl Chloroformate	4	2	4	4	4	1
Ethylcyclopentane	1	4	1	3	4	1
Ethylene Chloride	4	4	2	4	4	1
Ethylene Chlorohydrin	4	2	1	2	3	1
Ethylene Diamine	1	1	4	1	1	1*
Ethylene Dibromide	4	3	1	4	4	1
Ethylene Dichloride	4	3	1	4	4	1
Ethyl Ether	3	3	4	4	4	1
Ethyl Formate	4	2	1	2	X	1*
Ethylene Glycol	1	1	1	1	1	1
Ethylene Oxide	4	3	4	4	4	1
Ethylene Trichloride	4	3	1	4	4	1
Ethyl Hexanol	1	1	1	1	2	1

Fluid	Nitrile	EPDM	Viton®	Neoprene	Silicone	Kalrez®
Ethyl Mercaptan	4	X	2	3	3	1
Ethyl Oxalate	4	1	2	4	4	1
Ethyl Silicate	1	1	1	1	X	1
Fatty Acids	2	3	1	2	3	1
Ferric Chloride	1	1	1	2	2	1
Ferric Nitrate	1	1	1	1	2	1
Formaldehyde	3	2	4	3	2	1
Freon, 11	4	4	2	4	4	2*
Freon, 12	2	3	3	1	4	2*
Freon, 13	1	1	1	1	4	2*
Freon, 14	1	1	1	1	4	2*
Freon, 21	4	4	4	3	4	1*
Freon, 22	4	3	4	1	4	1*
Freon, 31	4	1	4	1	X	1*
Freon, 32	1	1	4	1	X	1*
Fuel Oil, 1 and 2	1	4	1	2	4	1
Fuel Oil, Acidic	1	4	1	2	1	1
Fuel Oil, #6	2	4	1	4	1	1
Fuming Sulphuric Acid	4	4	1	4	4	1
Furfural	4	2	4	4	4	1
Furfuraldehyde	4	2	4	4	4	1
Furyl Carbinol	4	2	X	4	4	1
Gallic Acid	2	2	1	2	X	1
Gasoline	1	4	1	4	4	1
Gelatin	1	1	1	1	1	1
Glacial Acetic Acid	2	2	4	4	2	1
Glucose	1	1	1	1	1	1
Glycerine - Glycerol	1	1	1	1	1	1
Glycols	1	1	1	1	1	1
Grease, Petroleum Base	1	4	1	3	4	1
Green Sulphate Liquor	2	1	1	2	X	1

1 = Satisfactory 2 = Fair 3 = Marginal 4 = Unsatisfactory X = Consult Factory (Insufficient Data)
 * indicates that differences may exist between KALREZ® compounds in certain applications

Fluid	Nitrile	EPDM	Viton®	Neoprene	Silicone	Kalrez®
Halowax Oil	4	4	1	4	4	1*
Heavy Water	1	1	X	2	1	1
Helium	1	1	1	1	1	1
Hydraulic Oil, Petroleum Base, Ind.	1	4	1	2	2	1
Hydrazine	2	1	4	2	2	1*
Hydrobromic Acid	4	1	1	4	4	1
Hydrobromic Acid 40%	4	1	1	2	4	2
Hydrocarbons, Saturated	1	4	1	2	4	1
Hydrochloric Acid	2	1	1	2	4	1
Hydrocyanic Acid	2	1	1	2	3	1
Hydrofluosilicic Acid	2	1	1	2	4	1
Hydrogen Gas, Cold	1	1	1	1	3	1
Hydrogen Gas, Hot	1	1	1	1	3	1
Hydrogen Peroxide	2	1	1	1	1	1
Hydrogen Peroxide 90%	4	3	1	4	2	1
Hydrogen Sulfide Dry, Cold	1	1	4	1	3	1
Hydrogen Sulfide Dry, Hot	4	1	4	2	3	1
Hydrogen Sulfide Wet, Cold	4	1	4	1	3	1
Hydrogen Sulfide Wet, Hot	4	1	4	2	3	1
Hypochlorous Acid	4	2	1	4	X	1
Iodine	2	2	1	4	X	1
Iodine Pentafluoride	4	4	4	4	4	2*
Isobutyl Alcohol	2	1	1	1	1	1
Iso-Butyl N-Butyrate	4	1	1	4	X	1
Isododecane	1	4	1	2	4	1
Iso Octane	1	4	1	2	4	1
Isophorone (Ketone)	4	2	4	4	4	1
Isopropanol	2	1	1	2	1	1
Isopropyl Acetate	4	2	4	4	4	1
Isopropyl Alcohol	2	1	1	2	1	1
Isopropyl Chloride	4	4	1	4	4	1

Fluid	Nitrile	EPDM	Viton®	Neoprene	Silicone	Kalrez®
Isopropyl Ether	2	4	4	3	4	1
Lactic Acid, Cold	1	1	1	1	1	1
Lactic Acid, Hot	4	4	1	4	2	1
Lacquers	4	4	4	4	4	1
Lacquer Solvents	4	4	4	4	4	1
Lard, Animal Fat	1	2	1	2	2	1
Lead Acetate	2	1	4	2	4	1
Lead Nitrate	1	1	X	1	2	1
Lead Sulphamate	2	1	1	1	2	1
Linoleic Acid	2	4	2	2	2	1
Linseed Oil	1	3	1	3	1	1
Liquid Oxygen	4	4	4	4	4	1
Liquid Petroleum Gas	1	4	1	2	3	1
Lubricating Oils, Di-ester	2	4	1	3	4	1
Lubricating Oils, petroleum	1	4	1	2	4	1
Lye Solutions	2	1	2	2	2	1
Magnesium Chloride	1	1	1	1	1	1
Magnesium Hydroxide	2	1	1	2	X	1
Magnesium Sulphite	1	1	1	1	1	1
Magnesium Salts	1	1	1	1	1	1
Maleic Acid	4	4	1	4	X	1
Maleic Anhydride	4	2	4	4	X	1
Malic Acid	1	2	1	2	2	1
Mercuric Chloride	1	1	1	1	X	1
Mercury	1	1	1	1	X	1
Mercury Vapors	1	1	1	1	X	1
Methane	1	4	1	2	4	1
Methanol	4	1	4	1	1	1
Methyl Acetate	4	2	4	2	4	1
Methyl Acetoacetate	4	2	4	4	2	1*
Methyl Acrylate	4	2	4	2	4	1

1 = Satisfactory 2 = Fair 3 = Marginal 4 = Unsatisfactory X = Consult Factory (Insufficient Data)
 * indicates that differences may exist between KALREZ® compounds in certain applications

Fluid	Nitrile	EPDM	Viton®	Neoprene	Silicone	Kalrez®
Methylacrylic Acid	4	2	3	2	4	1
Methyl Alcohol	4	1	4	1	1	1
Methyl Benzoate	4	4	1	4	4	1
Methyl Bromide	2	4	1	4	X	1
Methyl Butyl Ketone	4	1	4	4	4	1
Methyl Carbonate	4	4	1	4	4	1
Methyl Cellosolve	3	2	4	3	4	1
Methyl Cellulose	2	2	4	2	2	1
Methyl Chloride	4	3	1	4	4	1
Methyl Chloroformate	4	4	1	4	4	1
Methyl Ether	1	4	1	3	1	1
Methyl Ethyl Ketone	4	1	4	4	4	1
Methyl Ethyl Ketone Peroxide	4	4	4	4	2	1
Methyl Formate	4	2	X	2	X	1*
Methyl Isopropyl Ketone	4	2	4	4	4	1
Milk	1	1	1	1	1	1
Mineral Oils	1	3	1	2	2	1
Naptha	2	4	1	4	4	1
Naphthalene	4	4	1	4	4	1
Naphthenic Acid	2	4	1	4	4	1
Natural Gas	1	4	1	1	4	1
Neon	1	1	1	1	1	1
Nickel Acetate	2	1	4	2	4	1
Nickel Chloride	1	1	1	2	1	1
Nickel Salts	1	1	1	2	1	1
Nickel Sulfate	1	1	1	1	1	1
Niter Cake	1	1	1	1	1	1
Nitroethane	4	2	4	2	4	1
Nitrogen	1	1	1	1	1	1
Nitromethane	4	2	4	3	4	1
Nitropropane	4	2	4	4	4	1

Fluid	Nitrile	EPDM	Viton®	Neoprene	Silicone	Kalrez®
Nitrous Oxide	1	1	1	X	1	1
Octadecane	1	4	1	2	4	1
N-Octane	1	4	1	4	4	1
Octyl Alcohol	2	3	1	2	2	1
Oleic Acid	3	4	2	4	4	1
Oleum (Fuming Sulfuric Acid)	4	4	1	4	4	1
Oleum Spirits	2	4	1	3	4	1
Olive Oil	1	2	1	2	3	1
Orthochloro Ethyl Benzene	4	4	1	4	4	1
Ortho-Dichlorobenzene	4	4	1	4	4	1
Oxalic Acid	2	1	1	2	2	1
Oxygen, Cold	2	1	1	1	1	1*
Oxygen, 200-400°F	4	4	2	4	1	1*
Ozone	4	1	1	2	1	1
Paint Thinner, Duco	4	4	2	4	4	1
Peanut Oil	1	3	1	3	1	1
Pentane, 2 Methyl	1	4	1	2	4	1
Perchloric Acid - 2N	4	2	1	2	4	1*
Perchloroethylene	2	4	1	4	4	1*
Petrolatum	1	4	1	2	4	1
Petroleum Oil, Crude	1	4	1	2	4	1*
Petroleum Oil, Below 250°F	1	4	1	2	2	1
Petroleum Oil, Above 250°F	4	4	2	4	4	1
Phenol	4	4	1	4	4	1
Phenylbenzene	4	4	1	4	4	1
Phenyl Ethyl Ether	4	4	4	4	4	1
Phenylhydrazine	4	2	1	4	X	1
Phorone	4	3	4	4	4	1
Phosphoric Acid	2	1	1	2	3	1
Phosphorous Trichloride	4	1	1	4	X	1
Pickling Solution	4	3	2	4	4	1

1 = Satisfactory 2 = Fair 3 = Marginal 4 = Unsatisfactory X = Consult Factory (Insufficient Data)
 * indicates that differences may exist between KALREZ® compounds in certain applications

Fluid	Nitrile	EPDM	Viton®	Neoprene	Silicone	Kalrez®
Picric Acid, H2O Solution	1	1	1	1	X	1
Picric Acid, Molten	2	2	1	2	4	1
Pine Oil	1	4	1	4	4	1
Plating Solutions, Chrome	4	2	1	4	2	1
Plating Solutions, Others	1	1	1	4	4	1
Pneumatic Service	1	1	1	1	4	1
Polyvinyl Acetate Emulsion	X	1	X	2	X	1
Potassium Acetate	2	1	4	2	4	1
Potassium Chloride	1	1	1	1	1	1
Potassium Cupro Cyanide	1	1	1	1	1	1
Potassium Cyanide	1	1	1	1	1	1
Potassium Dichromate	1	1	1	1	1	1
Potassium Hydroxide, 50%	2	1	4	2	3	1
Potassium Nitrate	1	1	1	1	1	1
Potassium Salts	1	1	1	1	1	1
Potassium Sulphate	1	1	1	1	1	1
Potassium Sulfite	1	1	1	1	1	1
Producer Gas	1	4	1	2	2	1
Propane	1	4	1	2	4	1
Propyl Acetate	4	2	4	4	4	1
N-Propyl Acetone	4	1	4	4	4	1
Propyl Alcohol	1	1	1	1	1	1
Propylene	3	4	1	4	4	1
Propylene Oxide	4	2	4	4	4	1*
Propyl Nitrate	4	2	4	4	4	1
Rapeseed Oil	2	1	1	2	4	1
Salicylic Acid	2	1	1	X	X	1
Santo Safe 300	4	3	1	4	1	1
Sewage	1	1	1	2	1	1
Silicate Esters	2	4	1	1	4	1
Silicone Greases	1	1	1	1	3	1

Fluid	Nitrile	EPDM	Viton®	Neoprene	Silicone	Kalrez®
Silicone Oils	1	1	1	1	3	1
Silver Nitrate	2	1	1	1	1	1
Soap Solutions	1	1	1	2	1	1
Soda Ash	1	1	1	1	1	1
Sodium Acetate	2	1	4	2	4	1
Sodium Bicarbonate	1	1	1	1	1	1
Sodium Borate	1	1	1	1	1	1
Sodium Carbonate (Soda Ash)	1	1	1	1	1	1
Sodium Bisulfate or Bisulfite	1	1	1	1	1	1
Sodium Chloride	1	1	1	1	1	1
Sodium Cyanide	1	1	X	1	1	1
Sodium Hypochlorite	2	1	1	2	2	1
Sodium Metaphosphate	1	1	1	2	X	1
Sodium Nitrate	2	1	X	2	4	1
Sodium Perborate	2	1	1	2	2	1
Sodium Peroxide	2	1	1	2	4	1
Sodium Phosphate	1	1	1	2	4	1
Sodium Salts	1	1	1	2	1	1
Sodium Silicate	1	1	1	1	X	1
Sodium Sulphate	1	1	1	1	1	1
Sodium Sulphide and Sulfite	1	1	1	1	1	1
Sodium Thiosulfate	2	1	1	1	1	1
Sour Crude Oil	3	4	1	4	4	1*
Sour Natural Gas	3	4	1	4	4	1*
Soybean Oil	1	3	1	3	1	1
Steam, Below 400°F	4	1	4	4	3	1*
Steam, 400° - 500°F	4	3	4	4	4	1*
Sucrose Solutions	1	1	1	2	1	1
Sulfur Liquors	2	2	1	2	4	1
Sulfur	4	1	1	1	X	1
Sulfur Molten	4	3	1	3	3	1

1 = Satisfactory 2 = Fair 3 = Marginal 4 = Unsatisfactory X = Consult Factory (Insufficient Data)
 * indicates that differences may exist between KALREZ® compounds in certain applications

Fluid	Nitrile	EPDM	Viton®	Neoprene	Silicone	Kalrez®
Sulfur Chloride	4	4	1	4	3	1
Sulfur Dioxide, Wet	4	1	4	2	2	1
Sulfur Dioxide, Dry	4	1	4	4	2	1
Sulfuric Acid	X	3	1	X	X	1
Sulfurous Acid	2	2	1	2	4	1
Sulfur Trioxide, Dry	4	2	1	4	2	1
Tannic Acid (10%)	1	1	1	1	2	1
Tar, bituminous	2	4	1	3	2	1
Tartaric Acid	1	2	1	2	1	1
Terpineol	2	3	1	4	X	1
Tertiary Butyl Alcohol	2	2	1	2	2	1
Tetrabutyl Titanate	2	1	1	2	4	1
Tetrachoroethane	4	4	1	4	X	1
Tetrachloroethylene	4	4	1	4	4	1
Tetraethyl Lead	2	4	1	2	X	1
Tetrahydrofuran	4	2	4	4	4	1
Toluene	4	4	1	4	4	1
Toluene Diisocyanate	4	2	4	4	4	1
Transmission Fluid Type A	1	4	1	2	2	1
Triacetin	2	1	4	2	X	1
Triaryl Phosphate	4	1	1	4	3	1
Tributoxyethyl Phosphate	4	1	1	4	X	1
Tributyl Mercaptan	4	4	1	4	4	1
Tributyl Phosphate	4	1	4	4	4	1
Trichloroacetic Acid	2	2	3	4	X	1
Trichloroethane	4	4	1	4	4	1
Trichloroethylene	3	4	1	4	4	1
Tricresyl Phosphate	4	1	2	3	3	1

Fluid	Nitrile	EPDM	Viton®	Neoprene	Silicone	Kalrez®
Triethanol Amine	3	2	4	2	X	1*
Trifluoroethane	4	4	1	4	4	1
Trinitrololuene	4	4	2	2	X	1
Trioctyl Phosphate	4	1	2	4	3	1
Tripoly Phosphate	4	1	2	3	3	1
Tung Oil (China Wood Oil)	1	4	1	2	4	1
Turbine Oil	1	4	1	4	4	1
Turpentine	1	4	1	4	4	1
Varnish	2	4	1	4	4	1
Vegetable Oil	1	3	1	3	1	1
Vinegar	2	2	3	2	3	1
Vinyl Chloride	X	4	X	X	X	1
Water	1	1	2	2	1	1*
Whiskey and Wines	1	1	1	1	1	1
White Pine Oil	2	4	1	4	4	1
White Oil	1	4	1	2	4	1
Wood Alcohol	1	1	4	1	1	1
Wood Oil	1	4	1	2	4	1
Xylene	4	4	1	4	4	1
Zinc Acetate	2	1	4	2	4	1
Zinc Chloride	1	1	1	1	X	1
Zinc Salts	1	1	1	1	1	1
Zinc Sulfate	1	1	1	1	1	1

1 = Satisfactory 2 = Fair 3 = Marginal 4 = Unsatisfactory X = Consult Factory (Insufficient Data)
 * indicates that differences may exist between KALREZ® compounds in certain applications

GROOVE DESIGN FOR O-RING INSTALLATION

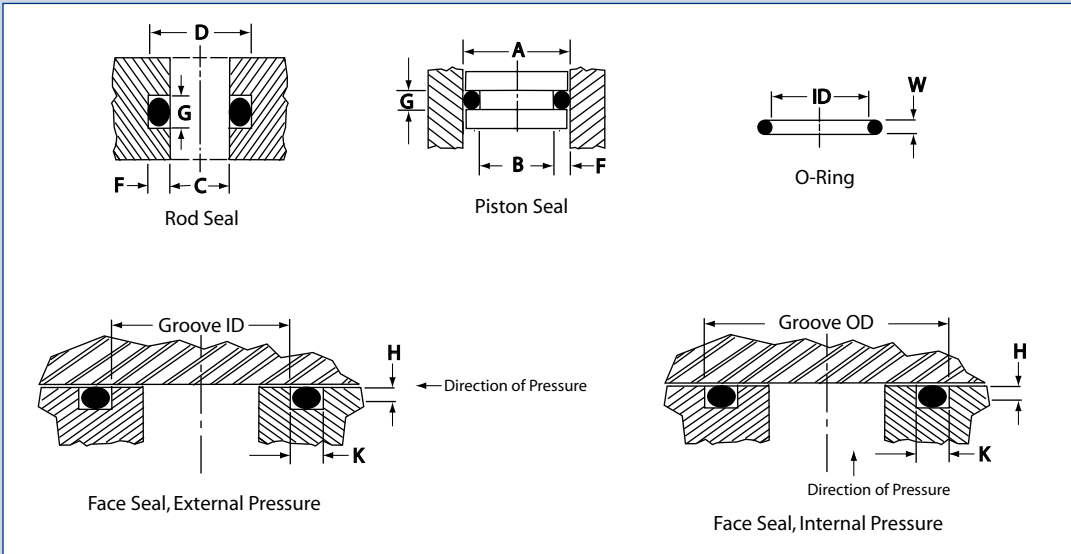

Uniform Dash Number	Actual Cross Section Diameter	Diametrical Squeeze (Minimum)		Gland Depth F		Groove Width G +/- .003			Flange Groove		Diametrical Clearance (Maximum) D		Eccentricity ³	Radius (R)
		Dynamic	Static	Dynamic +.000 -.001	Static +.000 -.004	No Backup Ring	One Backup Ring	Two Backup Rings	Depth H	K min	500 PSI	1500 PSI		
- 001	.040 + .003	.004	.006	.033	.031	.056	-	-	.028/.032	.068	.005	.0025	.002	.010
- 002	.050 + .003	.005	.008	.042	.039	.070	-	-	.037/.041	.078	.006	.003	.002	.010
- 003	.060 + .003	.006	.009	.051	.048	.084	-	-	.045/.050	.091	.007	.0035	.002	.016
- 004 thru -050	.070 + .003	.007	.011	.056	.051	.098	.140	.207	.051/.061	.095	.008	.004	.002	.016
102 thru -178	.103 + .003	.010	.015	.090	.082	.144	.173	.240	.081/.091	.140	.009	.004	.002	.016
-201 thru -284	.139 + .004	.014	.021	.121	.114	.195	.210	.277	.110/.120	.190	.010	.006	.003	.031
-309 thru -395	.210 + .005	.021	.032	.184	.173	.294	.313	.412	.170/.180	.280	.011	.007	.004	.031
-425 thru -475	.275 + .006	.028	.042	.241	.227	.385	.410	.540	.231/.241	.370	.012	.008	.005	.047

Note 1. The following sizes are not normally recommended for dynamic service, although special applications may permit their use:

-001 thru -003 -013 thru -050
 -117 thru -178 -223 thru -284
 -350 thru -395 -461 thru -475

Note 2. Clearances shown are based on 70 durometer materials. The clearances must be held to an absolute minimum consistent with design requirements for temperature variations and should not exceed the values shown.

Note 3. Total indicator reading between groove and adjacent bearing surface. All surfaces and corners must be free of tool marks and scratches.

GROOVE DESIGN FOR O-RING INSTALLATION (CONT.)

O-Ring groove dimensions may be calculated as follows (refer to figures and chart on page 22):

Given:	Example	Given:	Example
Rod Diameter C	= 500	Cylinder Bore A	= 1000
O-ring Cross Section W	= 3/32" nominal	O-ring Cross Section W	= 1/8" nominal
Dynamic application		Static application	
No back-ups required		No back-ups required	
Determine:		Determine:	
O-ring size = AS-568-112 (1/2" ID x 3/32" W nominal dimensions)		O-ring size = AS568-210 (1" OD x 1/8" W nominal dimensions)	
Gland Depth F = 0.090 +.000 / -.001" (from chart)		Gland Depth F = 0.114" +.000 / -.004" (from chart)	
Groove Width G = .144 +/- .003" (from chart)		Groove Width G = .195 +/- .003" (from chart)	
Rod Gland D = C + 2F = .500" + 2 x .090" = .680"		Rod Gland B = A-2F = 1.000" - 2 x .114" = .772"	

GENERAL PURPOSE LUBRICANTS FOR COMMON O-RING ELASTOMERS

In all dynamic applications, proper lubrication and good heat dissipation are essential to long seal life and performance. In pneumatic applications, supplemental lubrication should be provided. Lubricants should be selected on the basis of the material of which the O-Ring is made and the type of service to which it will be subjected. (See Table). In other instances the lubricant can be molded into the O-Ring, or Teflon or other coatings can be applied to the surface.

Type of Elastomer	Type of Service	Lubricant	Temperature Range, °F
Nitrile	Hydraulic Oils	Petroleum	-20 to 180
	Severe Service	Barium Grease	-20 to 300
	Pneumatic or Vacuum	Dow Corning: DC-55	-65 to 275
Fluorocarbon	Hydraulic Oils	Petrolatum	-20 to 180
	High Temperature & Vacuum	Dow Corning: DC-55	-65 to 275
Chloroprene	Hydraulic Oils Vacuum	Petrolatum	-20 to 180
Silicone	General	Dow Corning: FS-1292	-20 to 180
	High Temperature Petrolatum		-20 to 400
Ethylene-Propylene	Skydrol Steam & Hot Water	Aviation Fuel	-65 to 300
		Service Co: MCS-352	-32 to 350
		Dow Corning: DC4, DC-7, DC-55	

Size Ref. AS 568	Nominal Size (Inches)			Actual Size (Inches)		Actual Size (Millimeters)	
	I.D.	O.D.	W	I.D.	W	I.D.	W
-001	1/32	3/32	1/32	.029+/- .004	.040+/- .003	.74 +/- 0.10	1.02 +/- 0.08
-002	3/64	9/64	3/64	.042 +/- .004	.050 +/- .003	1.07 +/- 0.10	1.27 +/- 0.08
-003	1/16	3/16	1/16	.056 +/- .004	.060 +/- .003	1.42 +/- 0.10	1.53 +/- 0.08
-004	5/64	13/64	1/16	.070 +/- .005	.070 +/- .003	1.78 +/- 0.12	1.78 +/- 0.08
-005	3/32	7/32	1/16	.101 +/- .005	.070 +/- .003	2.57 +/- 0.12	1.78 +/- 0.08
-006	1/8	1/4	1/16	.114 +/- .005	.070 +/- .003	2.90 +/- 0.12	1.78 +/- 0.08
-007	5/32	9/32	1/16	.145 +/- .005	.070 +/- .003	3.69 +/- 0.12	1.78 +/- 0.08
-008	3/16	5/16	1/16	.176 +/- .005	.070 +/- .003	4.47 +/- 0.12	1.78 +/- 0.08
-009	7/32	11/32	1/16	.208 +/- .005	.070 +/- .003	5.29 +/- 0.12	1.78 +/- 0.08
-010	1/4	3/8	1/16	.239 +/- .005	.070 +/- .003	6.07 +/- 0.12	1.78 +/- 0.08
-011	5/16	7/16	1/16	.301 +/- .005	.070 +/- .003	7.65 +/- 0.12	1.78 +/- 0.08
-012	3/8	1/2	1/16	.364 +/- .005	.070 +/- .003	9.25 +/- 0.12	1.78 +/- 0.08
-013	7/16	9/16	1/16	.426 +/- .005	.070 +/- .003	10.82 +/- 0.12	1.78 +/- 0.08
-014	1/2	5/8	1/16	.489 +/- .005	.070 +/- .003	12.42 +/- 0.12	1.78 +/- 0.08
-015	9/16	11/16	1/16	.551 +/- .007	.070 +/- .003	14.00 +/- 0.17	1.78 +/- 0.08
-016	5/8	3/4	1/16	.614 +/- .009	.070 +/- .003	15.60 +/- 0.22	1.78 +/- 0.08
-017	11/16	13/16	1/16	.676 +/- .009	.070 +/- .003	17.17 +/- 0.22	1.78 +/- 0.08
-018	3/4	7/8	1/16	.739 +/- .009	.070 +/- .003	18.77 +/- 0.22	1.78 +/- 0.08
-019	13/16	15/16	1/16	.801 +/- .009	.070 +/- .003	20.35 +/- 0.22	1.78 +/- 0.08
-020	7/8	1	1/16	.864 +/- .009	.070 +/- .003	21.95 +/- 0.22	1.78 +/- 0.08
-021	15/16	1-1/16	1/16	.926 +/- .009	.070 +/- .003	23.52 +/- 0.23	1.78 +/- 0.08
-022	1	1-1/8	1/16	.989 +/- .010	.070 +/- .003	25.12 +/- 0.25	1.78 +/- 0.08
-023	1-1/16	1-3/16	1/16	1.051 +/- .010	.070 +/- .003	26.70 +/- 0.25	1.78 +/- 0.08
-024	1-1/8	1-1/4	1/16	1.114 +/- .010	.070 +/- .003	28.30 +/- 0.25	1.78 +/- 0.08
-025	1-3/16	1-5/16	1/16	1.176 +/- .011	.070 +/- .003	29.87 +/- 0.28	1.78 +/- 0.08
-026	1-1/4	1-3/8	1/16	1.239 +/- .011	.070 +/- .003	31.47 +/- 0.28	1.78 +/- 0.08
-027	1-5/16	1-7/16	1/16	1.301 +/- .011	.070 +/- .003	33.05 +/- 0.28	1.78 +/- 0.08
-028	1-3/8	1-1/2	1/16	1.364 +/- .013	.070 +/- .003	34.65 +/- 0.33	1.78 +/- 0.08
-029	1-1/2	1-5/8	1/16	1.489 +/- .013	.070 +/- .003	37.82 +/- 0.33	1.78 +/- 0.08
-030	1-5/8	1-3/4	1/16	1.614 +/- .013	.070 +/- .003	41.00 +/- 0.33	1.78 +/- 0.08
-031	1-3/4	1-7/8	1/16	1.739 +/- .015	.070 +/- .003	44.17 +/- 0.38	1.78 +/- 0.08
-032	1-7/8	2	1/16	1.864 +/- .015	.070 +/- .003	47.35 +/- 0.38	1.78 +/- 0.08
-033	2	2-1/8	1/16	1.989 +/- .018	.070 +/- .003	50.52 +/- 0.46	1.78 +/- 0.08
-034	2-1/8	2-1/4	1/16	2.114 +/- .018	.070 +/- .003	53.70 +/- 0.46	1.78 +/- 0.08
-035	2-1/4	2-3/8	1/16	2.239 +/- .018	.070 +/- .003	56.87 +/- 0.46	1.78 +/- 0.08
-036	2-3/8	2-1/2	1/16	2.364 +/- .018	.070 +/- .003	60.04 +/- 0.46	1.78 +/- 0.08
-037	2-1/2	2-5/8	1/16	2.489 +/- .018	.070 +/- .003	63.22 +/- 0.46	1.78 +/- 0.08
-038	2-5/8	2-3/4	1/16	2.614 +/- .020	.070 +/- .003	66.40 +/- 0.50	1.78 +/- 0.08
-039	2-3/4	2-7/8	1/16	2.739 +/- .020	.070 +/- .003	69.57 +/- .050	1.78 +/- 0.08
-040	2-7/8	3	1/16	2.864 +/- .020	.070 +/- .003	72.75 +/- .050	1.78 +/- 0.08

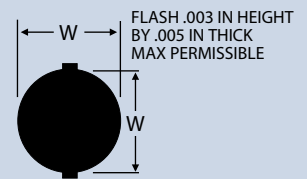
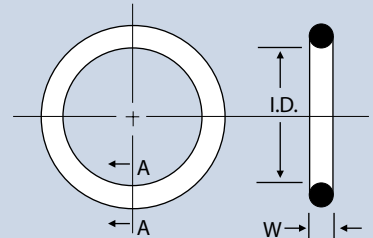

ENLARGED SECTION A.A

STATIC SEALING

Most O-Rings are used in static service (the O-Ring and metal surfaces remain relatively fixed). They may be applied as face seals or radial seals. In face seal applications, the O-Ring should seat against the low pressure side of the groove .

Size Ref. AS 568	Nominal Size (Inches)			Actual Size (Inches)		Actual Size (Millimeters)	
	I.D.	O.D.	W	I.D.	W	I.D.	W
-041	3	3-1/8	1/16	2.989 +/- .024	.070 +/- .003	75.92 +/- 0.61	1.78 +/- 0.08
-042	3-1/4	3-3/8	1/16	3.239 +/- .024	.070 +/- .003	82.27 +/- 0.61	1.78 +/- 0.08
-043	3-1/2	3-5/8	1/16	3.489 +/- .024	.070 +/- .003	88.62 +/- 0.61	1.78 +/- 0.08
-044	3-3/4	3-7/8	1/16	3.739 +/- .027	.070 +/- .003	94.97 +/- 0.69	1.78 +/- 0.08
-045	4	4-1/8	1/16	3.989 +/- .027	.070 +/- .003	101.32 +/- 0.69	1.78 +/- 0.08
-046	4-1/4	4-3/8	1/16	4.239 +/- .030	.070 +/- .003	107.67 +/- 0.76	1.78 +/- 0.08
-047	4-1/2	4-5/8	1/16	4.489 +/- .030	.070 +/- .003	114.02 +/- 0.76	1.78 +/- 0.08
-048	4-3/4	4-7/8	1/16	4.739 +/- .030	.070 +/- .003	120.37 +/- 0.76	1.78 +/- 0.08
-049	5	5-1/8	1/16	4.989 +/- .037	.070 +/- .003	126.72 +/- 0.94	1.78 +/- 0.08
-050	5-1/4	5-3/8	1/16	5.239 +/- .037	.070 +/- .003	133.07 +/- 0.94	1.78 +/- 0.08
-051	O ring sizes not assigned						
Thru	O ring sizes not assigned						
-101	O ring sizes not assigned						
-102	1/16	1/4	3/32	.049 +/- .005	.103 +/- .003	1.24 +/- 0.12	2.62 +/- 0.08
-103	3/32	9/32	3/32	.081 +/- .005	.103 +/- .003	2.05 +/- 0.12	2.62 +/- 0.08
-104	1/8	5/16	3/32	.112 +/- .005	.103 +/- .003	2.84 +/- 0.12	2.62 +/- 0.08
-105	5/32	11/32	3/32	.143 +/- .005	.103 +/- .003	3.63 +/- 0.12	2.62 +/- 0.08
-106	3/16	3/8	3/32	.174 +/- .005	.103 +/- .003	4.42 +/- 0.12	2.62 +/- 0.08
-107	7/32	13/32	3/32	.206 +/- .005	.103 +/- .003	5.23 +/- 0.12	2.62 +/- 0.08
-108	1/4	7/16	3/32	.237 +/- .005	.103 +/- .003	6.02 +/- 0.12	2.62 +/- 0.08
-109	5/16	1/2	3/32	.299 +/- .005	.103 +/- .003	7.60 +/- 0.12	2.62 +/- 0.08
-110	3/8	9/16	3/32	.362 +/- .005	.103 +/- .003	9.19 +/- 0.12	2.62 +/- 0.08
-111	7/16	5/8	3/32	.424 +/- .005	.103 +/- .003	10.77 +/- 0.12	2.62 +/- 0.08
-112	1/2	11/16	3/32	.487 +/- .005	.103 +/- .003	12.37 +/- 0.12	2.62 +/- 0.08
-113	9/16	3/4	3/32	.549 +/- .005	.103 +/- .003	13.95 +/- 0.17	2.62 +/- 0.08
-114	5/8	13/16	3/32	.612 +/- .009	.103 +/- .003	15.54 +/- 0.22	2.62 +/- 0.08
-115	11/16	7/8	3/32	.674 +/- .009	.103 +/- .003	17.12 +/- 0.22	2.62 +/- 0.08
-116	3/4	15/16	3/32	.737 +/- .009	.103 +/- .003	18.72 +/- 0.22	2.62 +/- 0.08
-117	13/16	1	3/32	.799 +/- .010	.103 +/- .003	20.29 +/- 0.25	2.62 +/- 0.08
-118	7/8	1-1/16	3/32	.862 +/- .010	.103 +/- .003	21.90 +/- 0.25	2.62 +/- 0.08
-119	15/16	1-1/8	3/32	.924 +/- .010	.103 +/- .003	23.47 +/- 0.25	2.62 +/- 0.08
-120	1	1-3/16	3/32	.987 +/- .010	.103 +/- .003	25.07 +/- 0.25	2.62 +/- 0.08
-121	1-1/16	1-1/4	3/32	1.049 +/- .010	.103 +/- .003	26.65 +/- 0.25	2.62 +/- 0.08
-122	1-1/8	1-5/16	3/32	1.112 +/- .010	.103 +/- .003	28.25 +/- 0.25	2.62 +/- 0.08
-123	1-3/16	1-3/8	3/32	1.174 +/- .012	.103 +/- .003	29.82 +/- 0.30	2.62 +/- 0.08
-124	1-1/4	1-7/16	3/32	1.237 +/- .012	.103 +/- .003	31.42 +/- 0.30	2.62 +/- 0.08
-125	1-5/16	1-1/2	3/32	1.299 +/- .012	.103 +/- .003	32.99 +/- 0.30	2.62 +/- 0.08
-126	1-3/8	1-9/16	3/32	1.362 +/- .012	.103 +/- .003	34.60 +/- 0.30	2.62 +/- 0.08
-127	1-7/16	1-5/8	3/32	1.424 +/- .012	.103 +/- .003	36.17 +/- 0.30	2.62 +/- 0.08
-128	1-1/2	1-11/16	3/32	1.487 +/- .012	.103 +/- .003	37.77 +/- .030	2.62 +/- 0.08
-129	1-9/16	1-3/4	3/32	1.549 +/- .015	.103 +/- .003	39.35 +/- 0.38	2.62 +/- 0.08
-130	1-5/8	1-13/16	3/32	1.612 +/- .015	.103 +/- .003	40.95 +/- 0.38	2.62 +/- 0.08

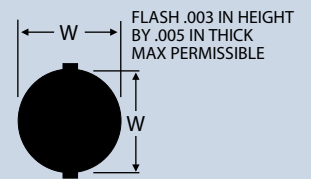
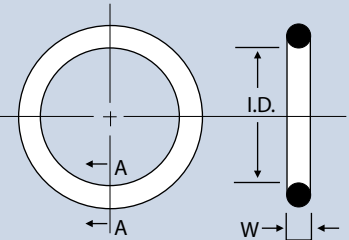

ENLARGED SECTION A.A.

DYNAMIC SEALING

The O-Ring moves relative to the mating surface. A moving seal may be further classified by the type of motion: reciprocating, oscillating, or rotating. The greatest number of dynamic seals are used in reciprocating service in cylinders, valves, and linear actuators. Oscillating motion is encountered in swivels and valve stems. When an O-Ring is used on a rotating shaft, it should be limited to light duty where the shaft speed is low and some fluid bypass is acceptable.

Size Ref. AS 568	Nominal Size (Inches)			Actual Size (Inches)		Actual Size (Millimeters)	
	I.D.	O.D.	W	I.D.	W	I.D.	W
-131	1-11/16	1-7/8	3/32	1.674 +/- .015	.103 +/- .003	42.52 +/- 0.38	2.62 +/- 0.08
-132	1-3/4	1-15/16	3/32	1.737 +/- .015	.103 +/- .003	44.12 +/- 0.38	2.62 +/- 0.08
-133	1-13/16	2	3/32	1.799 +/- .015	.103 +/- .003	45.70 +/- 0.38	2.62 +/- 0.08
-134	1-7/8	2-1/16	3/32	1.862 +/- .015	.103 +/- .003	47.30 +/- 0.38	2.62 +/- 0.08
-135	1-15/16	2-1/8	3/32	1.925 +/- .017	.103 +/- .003	48.90 +/- 0.43	2.62 +/- 0.08
-136	2	2-3/16	3/32	1.987 +/- .017	.103 +/- .003	50.47 +/- 0.43	2.62 +/- 0.08
-137	2-1/16	2-1/4	3/32	2.050 +/- .017	.103 +/- .003	52.07 +/- 0.43	2.62 +/- 0.08
-138	2-1/8	2-5/16	3/32	2.112 +/- .017	.103 +/- .003	53.65 +/- 0.43	2.62 +/- 0.08
-139	2-3/16	2-3/8	3/32	2.175 +/- .017	.103 +/- .003	55.25 +/- 0.43	2.62 +/- 0.08
-140	2-1/4	2-7/16	3/32	2.237 +/- .017	.103 +/- .003	56.82 +/- 0.43	2.62 +/- 0.08
-141	2-5/16	2-1/2	3/32	2.300 +/- .020	.103 +/- .003	58.42 +/- 0.50	2.62 +/- 0.08
-142	2-3/8	2-9/16	3/32	2.362 +/- .020	.103 +/- .003	60.00 +/- 0.50	2.62 +/- 0.08
-143	2-7/16	2-5/8	3/32	2.425 +/- .020	.103 +/- .003	61.60 +/- 0.50	2.62 +/- 0.08
-144	2-1/2	2-11/16	3/32	2.487 +/- .020	.103 +/- .003	63.17 +/- 0.50	2.62 +/- 0.08
-145	2-9/16	2-3/4	3/32	2.550 +/- .020	.103 +/- .003	64.77 +/- 0.50	2.62 +/- 0.08
-146	2-5/8	2-13/16	3/32	2.612 +/- .020	.103 +/- .003	66.35 +/- 0.50	2.62 +/- 0.08
-147	2-11/16	2-7/8	3/32	2.675 +/- .022	.103 +/- .003	67.95 +/- 0.55	2.62 +/- 0.08
-148	2-3/4	2-15/16	3/32	2.737 +/- .022	.103 +/- .003	69.52 +/- 0.55	2.62 +/- 0.08
-149	2-13/16	3	3/32	2.800 +/- .022	.103 +/- .003	71.12 +/- 0.55	2.62 +/- 0.08
-150	2-7/8	3-1/16	3/32	2.862 +/- .022	.103 +/- .003	72.70 +/- 0.55	2.62 +/- 0.08
-151	3	3-3/16	3/32	2.987 +/- .024	.103 +/- .003	75.87 +/- 0.61	2.62 +/- 0.08
-152	3-1/4	3-7/16	3/32	3.237 +/- .024	.103 +/- .003	82.22 +/- 0.61	2.62 +/- 0.08
-153	3-1/2	3-11/16	3/32	3.487 +/- .024	.103 +/- .003	88.57 +/- 0.61	2.62 +/- 0.08
-154	3-3/4	3-15/16	3/32	3.737 +/- .028	.103 +/- .003	94.92 +/- 0.71	2.62 +/- 0.08
-155	4	4-3/16	3/32	3.987 +/- .028	.103 +/- .003	101.27 +/- 0.71	2.62 +/- 0.08
-156	4-1/4	4-7/16	3/32	4.237 +/- .030	.103 +/- .003	107.62 +/- 0.76	2.62 +/- 0.08
-157	4-1/2	4-11/16	3/32	4.487 +/- .030	.103 +/- .003	113.97 +/- 0.76	2.62 +/- 0.08
-158	4-3/4	4-15/16	3/32	4.737 +/- .030	.103 +/- .003	120.32 +/- 0.76	2.62 +/- 0.08
-159	5	5-3/16	3/32	4.987 +/- .035	.103 +/- .003	126.67 +/- 0.89	2.62 +/- 0.08
-160	5-1/4	5-7/16	3/32	5.237 +/- .035	.103 +/- .003	133.02 +/- 0.89	2.62 +/- 0.08
-161	5-1/2	5-11/16	3/32	5.487 +/- .035	.103 +/- .003	139.37 +/- 0.89	2.62 +/- 0.08
-162	5-3/4	5-15/16	3/32	5.737 +/- .035	.103 +/- .003	145.72 +/- 0.89	2.62 +/- 0.08
-163	6	6-3/16	3/32	5.987 +/- .035	.103 +/- .003	152.07 +/- 0.89	2.62 +/- 0.08
-164	6-1/4	6-7/16	3/32	6.237 +/- .040	.103 +/- .003	158.42 +/- 1.02	2.62 +/- 0.08
-165	6-1/2	6-11/16	3/32	6.487 +/- .040	.103 +/- .003	164.77 +/- 1.02	2.62 +/- 0.08
-166	6-3/4	6-15/16	3/32	6.737 +/- .040	.103 +/- .003	171.12 +/- 1.02	2.62 +/- 0.08
-167	7	7-3/16	3/32	6.987 +/- .040	.103 +/- .003	177.47 +/- 1.02	2.62 +/- 0.08
-168	7-1/4	7-7/16	3/32	7.237 +/- .045	.103 +/- .003	183.82 +/- 1.14	2.62 +/- 0.08
-169	7-1/2	7-11/16	3/32	7.487 +/- .045	.103 +/- .003	190.17 +/- 1.14	2.62 +/- 0.08
-170	7-3/4	7-15/16	3/32	7.737 +/- .045	.103 +/- .003	196.52 +/- 1.14	2.62 +/- 0.08

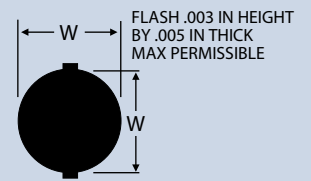
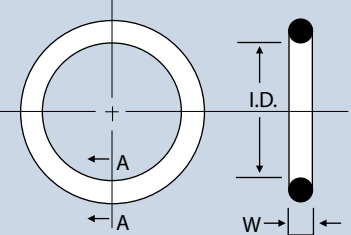

ENLARGED SECTION A.A

CAUSES OF O-RING FAILURE

- Extrusion and Nibbling
- Compression Set
- Spiral Failure
- Explosive Compression
- Abrasion
- Installation Damage
- Weather & Ozone Degradation
- Heat Aging & Oxidation
- Loss of Plasticizer

*Refer to the section Identifying O-Ring Failure for detailed descriptions.

Size Ref. AS 568	Nominal Size (Inches)			Actual Size (Inches)		Actual Size (Millimeters)	
	I.D.	O.D.	W	I.D.	W	I.D.	W
-171	8	8-3/16	3/32	7.987 +/- .045	.103 +/- .003	202.87 +/- 1.14	2.62 +/- 0.08
-172	8-1/4	8-7/16	3/32	8.237 +/- .050	.103 +/- .003	209.22 +/- 1.25	2.62 +/- 0.08
-173	8-1/2	8-11/16	3/32	8.487 +/- .050	.103 +/- .003	215.57 +/- 1.25	2.62 +/- 0.08
-174	8-3/4	8-15/16	3/32	8.737 +/- .050	.103 +/- .003	221.92 +/- 1.25	2.62 +/- 0.08
-175	9	9-3/16	3/32	8.987 +/- .050	.103 +/- .003	228.27 +/- 1.25	2.62 +/- 0.08
-176	9-1/4	9-7/16	3/32	9.237 +/- .055	.103 +/- .003	234.62 +/- 1.40	2.62 +/- 0.08
-177	9-1/2	9-11/16	3/32	9.487 +/- .055	.103 +/- .003	240.97 +/- 1.40	2.62 +/- 0.08
-178	9-3/4	9-15/16	3/32	9.737 +/- .055	.103 +/- .003	247.32 +/- 1.40	2.62 +/- 0.08
-179	O ring sizes not assigned						
Thru -200	O ring sizes not assigned						
-201	3/16	7/16	1/8	.171 +/- .005	.139 +/- .004	4.34 +/- 0.12	3.53 +/- 0.10
-202	1/4	1/2	1/8	.234 +/- .005	.139 +/- .004	5.94 +/- 0.12	3.53 +/- 0.10
-203	5/16	9/16	1/8	.296 +/- .005	.139 +/- .004	7.52 +/- 0.12	3.53 +/- 0.10
-204	3/8	5/8	1/8	.359 +/- .005	.139 +/- .004	9.12 +/- 0.12	3.53 +/- 0.10
-205	7/16	11/16	1/8	.421 +/- .005	.139 +/- .004	10.69 +/- 0.12	3.53 +/- 0.10
-206	1/2	3/4	1/8	.484 +/- .005	.139 +/- .004	12.29 +/- 0.12	3.53 +/- 0.10
-207	9/16	13/16	1/8	.546 +/- .007	.139 +/- .004	13.87 +/- 0.17	3.53 +/- 0.10
-208	5/8	7/8	1/8	.609 +/- .009	.139 +/- .004	15.47 +/- 0.23	3.53 +/- 0.10
-209	11/16	15/16	1/8	.671 +/- .009	.139 +/- .004	17.04 +/- 0.23	3.53 +/- 0.10
-210	3/4	1	1/8	.734 +/- .010	.139 +/- .004	18.64 +/- 0.25	3.53 +/- 0.10
-211	13/16	1-1/16	1/8	.796 +/- .010	.139 +/- .004	20.22 +/- 0.25	3.53 +/- 0.10
-212	7/8	1-1/8	1/8	.859 +/- .010	.139 +/- .004	21.82 +/- 0.25	3.53 +/- 0.10
-213	15/16	1-3/16	1/8	.921 +/- .010	.139 +/- .004	23.40 +/- 0.25	3.53 +/- 0.10
-214	1	1-1/4	1/8	.984 +/- .010	.139 +/- .004	25.00 +/- 0.25	3.53 +/- 0.10
-215	1-1/16	1-5/16	1/8	1.046 +/- .010	.139 +/- .004	26.57 +/- 0.25	3.53 +/- 0.10
-216	1-1/8	1-3/8	1/8	1.109 +/- .012	.139 +/- .004	28.17 +/- 0.30	3.53 +/- 0.10
-217	1-3/16	1-7/16	1/8	1.171 +/- .012	.139 +/- .004	29.75 +/- 0.30	3.53 +/- 0.10
-218	1-1/4	1-1/2	1/8	1.234 +/- .012	.139 +/- .004	31.34 +/- 0.30	3.53 +/- 0.10
-219	1-5/16	1-9/16	1/8	1.296 +/- .012	.139 +/- .004	32.92 +/- 0.30	3.53 +/- 0.10
-220	1-3/8	1-5/8	1/8	1.359 +/- .012	.139 +/- .004	34.52 +/- 0.30	3.53 +/- 0.10
-221	1-7/16	1-11/16	1/8	1.421 +/- .012	.139 +/- .004	36.10 +/- 0.30	3.53 +/- 0.10
-222	1-1/2	1-3/4	1/8	1.484 +/- .015	.139 +/- .004	37.70 +/- 0.38	3.53 +/- 0.10
-223	1-5/8	1-7/8	1/8	1.609 +/- .015	.139 +/- .004	40.87 +/- 0.38	3.53 +/- 0.10
-224	1-3/4	2	1/8	1.734 +/- .015	.139 +/- .004	44.05 +/- 0.38	3.53 +/- 0.10
-225	1-7/8	2-1/8	1/8	1.859 +/- .018	.139 +/- .004	47.22 +/- 0.46	3.53 +/- 0.10
-226	2	2-1/4	1/8	1.984 +/- .018	.139 +/- .004	50.40 +/- 0.46	3.53 +/- 0.10
-227	2-1/8	2-3/8	1/8	2.109 +/- .018	.139 +/- .004	53.57 +/- 0.46	3.53 +/- 0.10
-228	2-1/4	2-1/2	1/8	2.234 +/- .020	.139 +/- .004	56.75 +/- 0.50	3.53 +/- 0.10
-229	2-3/8	2-5/8	1/8	2.359 +/- .020	.139 +/- .004	59.92 +/- 0.50	3.53 +/- 0.10
-230	2-1/2	2-3/4	1/8	2.484 +/- .020	.139 +/- .004	63.10 +/- 0.50	3.53 +/- 0.10

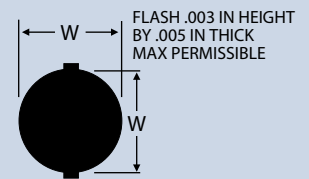
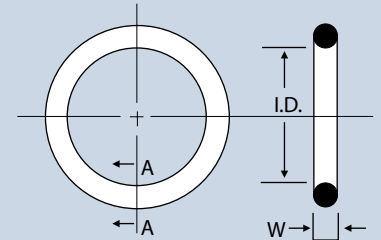

ENLARGED SECTION A.A

DMR™ O-RING KITS AND CUSTOM PACKAGING

A wide variety of O-Rings are standard in our kits, giving you the flexibility and the versatility to find the right fit for your application.

Daemar® can also provide you with custom kits to suit your needs. Call your Daemar® sales representative to find out more.

*Refer to the section O-Ring Kits for detailed descriptions of kit contents.

Size Ref. AS 568	Nominal Size (Inches)			Actual Size (Inches)		Actual Size (Millimeters)	
	I.D.	O.D.	W	I.D.	W	I.D.	W
-231	2-5/8	2-7/8	1/8	2.609 +/- .020	.139 +/- .004	66.27 +/- 0.50	3.53 +/- 0.10
-232	2-3/4	3	1/8	2.734 +/- .024	.139 +/- .004	69.44 +/- 0.61	3.53 +/- 0.10
-233	2-7/8	3-1/8	1/8	2.859 +/- .024	.139 +/- .004	72.62 +/- 0.61	3.53 +/- 0.10
-234	3	3-1/4	1/8	2.984 +/- .024	.139 +/- .004	75.79 +/- 0.61	3.53 +/- 0.10
-235	3-1/8	3-3/8	1/8	3.109 +/- .024	.139 +/- .004	78.97 +/- 0.61	3.53 +/- 0.10
-236	3-1/4	3-1/2	1/8	3.234 +/- .024	.139 +/- .004	82.14 +/- 0.61	3.53 +/- 0.10
-237	3-3/8	3-5/8	1/8	3.359 +/- .024	.139 +/- .004	85.32 +/- 0.61	3.53 +/- 0.10
-238	3-1/2	3-3/4	1/8	3.484 +/- .024	.139 +/- .004	88.49 +/- 0.61	3.53 +/- 0.10
-239	3-5/8	3-7/8	1/8	3.609 +/- .028	.139 +/- .004	91.67 +/- 0.71	3.53 +/- 0.10
-240	3-3/4	4	1/8	3.734 +/- .028	.139 +/- .004	94.84 +/- 0.71	3.53 +/- 0.10
-241	3-7/8	4-1/8	1/8	3.859 +/- .028	.139 +/- .004	98.02 +/- 0.71	3.53 +/- 0.10
-242	4	4-1/4	1/8	3.984 +/- .028	.139 +/- .004	101.19 +/- 0.71	3.53 +/- 0.10
-243	4-1/8	4-3/8	1/8	4.109 +/- .028	.139 +/- .004	104.37 +/- 0.71	3.53 +/- 0.10
-244	4-1/4	4-1/2	1/8	4.234 +/- .030	.139 +/- .004	107.54 +/- 0.76	3.53 +/- 0.10
-245	4-3/8	4-5/8	1/8	4.359 +/- .030	.139 +/- .004	110.72 +/- 0.76	3.53 +/- 0.10
-246	4-1/2	4-3/4	1/8	4.484 +/- .030	.139 +/- .004	113.89 +/- 0.76	3.53 +/- 0.10
-247	4-5/8	4-7/8	1/8	4.609 +/- .030	.139 +/- .004	117.89 +/- 0.76	3.53 +/- 0.10
-248	4-3/4	5	1/8	4.734 +/- .030	.139 +/- .004	120.24 +/- 0.76	3.53 +/- 0.10
-249	4-7/8	5-1/8	1/8	4.859 +/- .035	.139 +/- .004	123.42 +/- 0.89	3.53 +/- 0.10
-250	5	5-1/4	1/8	4.984 +/- .035	.139 +/- .004	126.59 +/- 0.89	3.53 +/- 0.10
-251	5-1/8	5-3/8	1/8	5.109 +/- .035	.139 +/- .004	129.77 +/- 0.89	3.53 +/- 0.10
-252	5-1/4	5-1/2	1/8	5.234 +/- .035	.139 +/- .004	132.94 +/- 0.89	3.53 +/- 0.10
-253	5-3/8	5-5/8	1/8	5.359 +/- .035	.139 +/- .004	136.12 +/- 0.89	3.53 +/- 0.10
-254	5-1/2	5-3/4	1/8	5.484 +/- .035	.139 +/- .004	139.30 +/- 0.89	3.53 +/- 0.10
-255	5-5/8	5-7/8	1/8	5.609 +/- .035	.139 +/- .004	142.47 +/- 0.89	3.53 +/- 0.10
-256	5-3/4	6	1/8	5.734 +/- .035	.139 +/- .004	145.65 +/- 0.89	3.53 +/- 0.10
-257	5-7/8	6-1/8	1/8	5.859 +/- .035	.139 +/- .004	148.82 +/- 0.89	3.53 +/- 0.10
-258	6	6-1/4	1/8	5.984 +/- .035	.139 +/- .004	152.00 +/- 0.89	3.53 +/- 0.10
-259	6-1/4	6-1/2	1/8	6.234 +/- .040	.139 +/- .004	158.35 +/- 1.02	3.53 +/- 0.10
-260	6-1/2	6-3/4	1/8	6.484 +/- .040	.139 +/- .004	164.70 +/- 1.02	3.53 +/- 0.10
-261	6-3/4	7	1/8	6.734 +/- .040	.139 +/- .004	171.05 +/- 1.02	3.53 +/- 0.10
-262	7	7-1/4	1/8	6.984 +/- .040	.139 +/- .004	177.40 +/- 1.02	3.53 +/- 0.10
-263	7-1/4	7-1/2	1/8	7.234 +/- .045	.139 +/- .004	183.75 +/- 1.14	3.53 +/- 0.10
-264	7-1/2	7-3/4	1/8	7.484 +/- .045	.139 +/- .004	190.10 +/- 1.14	3.53 +/- 0.10
-265	7-3/4	8	1/8	7.734 +/- .045	.139 +/- .004	196.45 +/- 1.14	3.53 +/- 0.10
-266	8	8-1/4	1/8	7.984 +/- .045	.139 +/- .004	202.80 +/- 1.14	3.53 +/- 0.10
-267	8-1/4	8-1/2	1/8	8.234 +/- .050	.139 +/- .004	209.15 +/- 1.25	3.53 +/- 0.10
-268	8-1/2	8-3/4	1/8	8.484 +/- .050	.139 +/- .004	215.50 +/- 1.25	3.53 +/- 0.10
-269	8-3/4	9	1/8	8.734 +/- .050	.139 +/- .004	221.85 +/- 1.25	3.53 +/- 0.10
-270	9	9-1/4	1/8	8.984 +/- .050	.139 +/- .004	228.20 +/- 1.25	3.53 +/- 0.10

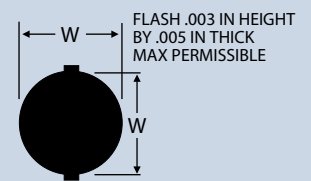
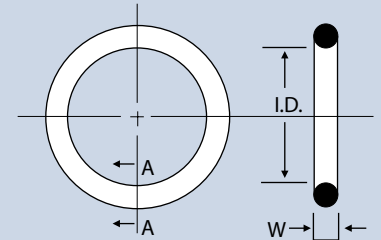

ENLARGED SECTION A.A

GRADE OF FLUOROCARBON

DMR™ o-rings use a grade of fluorocarbon equivalent to Dupont Grade A Viton.

Size Ref. AS 568	Nominal Size (Inches)			Actual Size (Inches)		Actual Size (Millimeters)	
	I.D.	O.D.	W	I.D.	W	I.D.	W
-271	9-1/4	9-1/2	1/8	9.234 +/- .055	.139 +/- .004	234.55 +/- 1.40	3.53 +/- 0.10
-272	9-1/2	9-3/4	1/8	9.484 +/- .055	.139 +/- .004	240.90 +/- 1.40	3.53 +/- 0.10
-273	9-3/4	10	1/8	9.734 +/- .055	.139 +/- .004	247.25 +/- 1.40	3.53 +/- 0.10
-274	10	10-1/4	1/8	9.984 +/- .055	.139 +/- .004	253.60 +/- 1.40	3.53 +/- 0.10
-275	10-1/2	10-3/4	1/8	10.484 +/- .055	.139 +/- .004	266.30 +/- 1.40	3.53 +/- 0.10
-276	11	11-1/4	1/8	10.984 +/- .065	.139 +/- .004	279.00 +/- 1.65	3.53 +/- 0.10
-277	11-1/2	11-3/4	1/8	11.484 +/- .065	.139 +/- .004	291.70 +/- 1.65	3.53 +/- 0.10
-278	12	12-1/4	1/8	11.984 +/- .065	.139 +/- .004	304.40 +/- 1.65	3.53 +/- 0.10
-279	13	13-1/4	1/8	12.984 +/- .065	.139 +/- .004	329.80 +/- 1.65	3.53 +/- 0.10
-280	14	14-1/4	1/8	13.984 +/- .065	.139 +/- .004	355.20 +/- 1.65	3.53 +/- 0.10
-281	15	15-1/4	1/8	14.984 +/- .065	.139 +/- .004	380.60 +/- 1.65	3.53 +/- 0.10
-282	16	16-1/4	1/8	15.955 +/- .075	.139 +/- .004	405.26 +/- 1.90	3.53 +/- 0.10
-283	17	17-1/4	1/8	16.955 +/- .080	.139 +/- .004	430.66 +/- 2.05	3.53 +/- 0.10
-284	18	18-1/4	1/8	17.955 +/- .085	.139 +/- .004	456.06 +/- 2.15	3.53 +/- 0.10
-285							
Thru	O ring sizes not assigned						
-308							
-309	7/16	13/16	3/16	.412 +/- .005	.210 +/- .005	10.46 +/- 0.12	5.34 +/- 0.12
-310	1/2	7/8	3/16	.475 +/- .005	.210 +/- .005	12.07 +/- 0.12	5.34 +/- 0.12
-311	9/16	15/16	3/16	.537 +/- .007	.210 +/- .005	13.64 +/- 0.17	5.34 +/- 0.12
-312	5/8	1	3/16	.600 +/- .009	.210 +/- .005	15.24 +/- 0.22	5.34 +/- 0.12
-313	11/16	1-1/16	3/16	.662 +/- .009	.210 +/- .005	16.81 +/- 0.22	5.34 +/- 0.12
-314	3/4	1-1/8	3/16	.725 +/- .010	.210 +/- .005	18.42 +/- 0.25	5.34 +/- 0.12
-315	13/16	1-3/16	3/16	.787 +/- .010	.210 +/- .005	19.99 +/- 0.25	5.34 +/- 0.12
-316	7/8	1-1/4	3/16	.850 +/- .010	.210 +/- .005	21.59 +/- 0.25	5.34 +/- 0.12
-317	15/16	1-5/16	3/16	.912 +/- .010	.210 +/- .005	23.16 +/- 0.25	5.34 +/- 0.12
-318	1	1-3/8	3/16	.975 +/- .010	.210 +/- .005	24.77 +/- 0.25	5.34 +/- 0.12
-319	1-1/16	1-7/16	3/16	1.037 +/- .010	.210 +/- .005	26.34 +/- 0.25	5.34 +/- 0.12
-320	1-1/8	1-1/2	3/16	1.100 +/- .012	.210 +/- .005	27.94 +/- 0.30	5.34 +/- 0.12
-321	1-3/16	1-9/16	3/16	1.162 +/- .012	.210 +/- .005	29.51 +/- 0.30	5.34 +/- 0.12
-322	1-1/4	1-5/8	3/16	1.225 +/- .012	.210 +/- .005	31.12 +/- 0.30	5.34 +/- 0.12
-323	1-5/16	1-11/16	3/16	1.287 +/- .012	.210 +/- .005	32.69 +/- 0.30	5.34 +/- 0.12
-324	1-3/8	1-3/4	3/16	1.350 +/- .012	.210 +/- .005	34.29 +/- 0.30	5.34 +/- 0.12
-325	1-1/2	1-7/8	3/16	1.475 +/- .015	.210 +/- .005	37.47 +/- 0.38	5.34 +/- 0.12
-326	1-5/8	2	3/16	1.600 +/- .015	.210 +/- .005	40.65 +/- 0.38	5.34 +/- 0.12
-327	1-3/4	2-1/8	3/16	1.725 +/- .015	.210 +/- .005	43.82 +/- 0.38	5.34 +/- 0.12
-328	1-7/8	2-1/4	3/16	1.850 +/- .015	.210 +/- .005	46.99 +/- 0.38	5.34 +/- 0.12
-329	2	2-3/8	3/16	1.975 +/- .018	.210 +/- .005	50.16 +/- 0.46	5.34 +/- 0.12
-330	2-1/8	2-1/2	3/16	2.100 +/- .018	.210 +/- .005	53.34 +/- 0.46	5.34 +/- 0.12

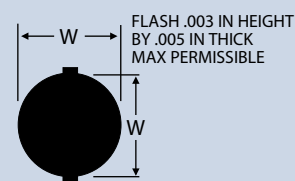
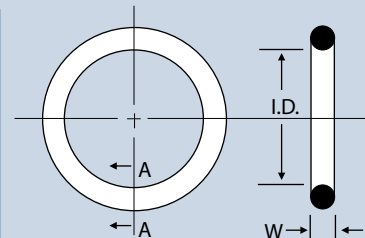

ENLARGED SECTION A.A.

EXTENDING O-RING SHELF LIFE

For materials such as Buna 'N', which are subject to deterioration, the following conditions are suggested for maximum life:

1. Ambient temperature not exceeding 120°F (49°C)
2. Exclusion of air (oxygen)
3. Exclusion of contamination
4. Exclusion of light (particularly sunlight)
5. Exclusion of ozone generating electrical devices
6. Exclusion of radiation

*Refer to the section Storage & Shelf Life for a more detailed description.

Size Ref. AS 568	Nominal Size (Inches)			Actual Size (Inches)		Actual Size (Millimeters)	
	I.D.	O.D.	W	I.D.	W	I.D.	W
-331	2-1/4	2-5/8	3/16	2.225 +/- .018	.210 +/- .005	56.52 +/- 0.46	5.34 +/- 0.12
-332	2-3/8	2-3/4	3/16	2.350 +/- .018	.210 +/- .005	59.69 +/- 0.46	5.34 +/- 0.12
-333	2-1/2	2-7/8	3/16	2.475 +/- .020	.210 +/- .005	62.87 +/- 0.50	5.34 +/- 0.12
-334	2-5/8	3	3/16	2.600 +/- .020	.210 +/- .005	66.04 +/- 0.50	5.34 +/- 0.12
-335	2-3/4	3-1/8	3/16	2.725 +/- .020	.210 +/- .005	69.22 +/- 0.50	5.34 +/- 0.12
-336	2-7/8	3-1/4	3/16	2.850 +/- .020	.210 +/- .005	72.39 +/- 0.50	5.34 +/- 0.12
-337	3	3-3/8	3/16	2.975 +/- .024	.210 +/- .005	75.57 +/- 0.61	5.34 +/- 0.12
-338	3-1/8	3-1/2	3/16	3.100 +/- .024	.210 +/- .005	78.74 +/- 0.61	5.34 +/- 0.12
-339	3-1/4	3-5/8	3/16	3.225 +/- .024	.210 +/- .005	81.92 +/- 0.61	5.34 +/- 0.12
-340	3-3/8	3-3/4	3/16	3.350 +/- .024	.210 +/- .005	85.09 +/- 0.61	5.34 +/- 0.12
-341	3-1/2	3-7/8	3/16	3.475 +/- .024	.210 +/- .005	88.27 +/- 0.61	5.34 +/- 0.12
-342	3-5/8	4	3/16	3.600 +/- .028	.210 +/- .005	91.44 +/- 0.71	5.34 +/- 0.12
-343	3-3/4	4-1/8	3/16	3.725 +/- .028	.210 +/- .005	94.62 +/- 0.71	5.34 +/- 0.12
-344	3-7/8	4-1/4	3/16	3.850 +/- .028	.210 +/- .005	97.79 +/- 0.71	5.34 +/- 0.12
-345	4	4-3/8	3/16	3.975 +/- .028	.210 +/- .005	100.96 +/- 0.71	5.34 +/- 0.12
-346	4-1/8	4-1/2	3/16	4.100 +/- .028	.210 +/- .005	104.14 +/- 0.71	5.34 +/- 0.12
-347	4-1/4	4-5/8	3/16	4.225 +/- .030	.210 +/- .005	107.32 +/- 0.76	5.34 +/- 0.12
-348	4-3/8	4-3/4	3/16	4.350 +/- .030	.210 +/- .005	110.49 +/- 0.76	5.34 +/- 0.12
-349	4-1/2	4-7/8	3/16	4.475 +/- .030	.210 +/- .005	113.67 +/- 0.76	5.34 +/- 0.12
-350	4-5/8	5	3/16	4.600 +/- .030	.210 +/- .005	116.84 +/- 0.76	5.34 +/- 0.12
-351	4-3/4	5-1/8	3/16	4.725 +/- .030	.210 +/- .005	120.02 +/- 0.76	5.34 +/- 0.12
-352	4-7/8	5-1/4	3/16	4.850 +/- .030	.210 +/- .005	123.19 +/- 0.76	5.34 +/- 0.12
-353	5	5-3/8	3/16	4.975 +/- .037	.210 +/- .005	126.37 +/- 0.94	5.34 +/- 0.12
-354	5-1/8	5-1/2	3/16	5.100 +/- .037	.210 +/- .005	129.54 +/- 0.94	5.34 +/- 0.12
-355	5-1/4	5-5/8	3/16	5.225 +/- .037	.210 +/- .005	132.72 +/- 0.94	5.34 +/- 0.12
-356	5-3/8	5-3/4	3/16	5.350 +/- .037	.210 +/- .005	135.89 +/- 0.94	5.34 +/- 0.12
-357	5-1/2	5-7/8	3/16	5.475 +/- .037	.210 +/- .005	139.07 +/- 0.94	5.34 +/- 0.12
-358	5-5/8	6	3/16	5.600 +/- .037	.210 +/- .005	142.24 +/- 0.94	5.34 +/- 0.12
-359	5-3/4	6-1/8	3/16	5.725 +/- .037	.210 +/- .005	145.42 +/- 0.94	5.34 +/- 0.12
-360	5-7/8	6-1/4	3/16	5.850 +/- .037	.210 +/- .005	148.59 +/- 0.94	5.34 +/- 0.12
-361	6	6-3/8	3/16	5.975 +/- .037	.210 +/- .005	151.77 +/- 0.94	5.34 +/- 0.12
-362	6-1/4	6-5/8	3/16	6.225 +/- .040	.210 +/- .005	158.12 +/- 1.02	5.34 +/- 0.12
-363	6-1-2	6-7/8+	3/16	6.475 +/- .040	.210 +/- .005	164.47 +/- 1.02	5.34 +/- 0.12
-364	6-3/4	7-1/8	3/16	6.725 +/- .040	.210 +/- .005	170.82 +/- 1.02	5.34 +/- 0.12
-365	7	7-3/8	3/16	6.975 +/- .040	.210 +/- .005	177.17 +/- 1.02	5.34 +/- 0.12
-366	7-1/4	7-5/8	3/16	7.225 +/- .045	.210 +/- .005	183.52 +/- 1.14	5.34 +/- 0.12
-367	7-1/2	7-7/8	3/16	7.475 +/- .045	.210 +/- .005	189.87 +/- 1.14	5.34 +/- 0.12
-368	7-3/4	8-1/8	3/16	7.725 +/- .045	.210 +/- .005	196.22 +/- 1.14	5.34 +/- 0.12
-369	8	8-3/8	3/16	7.975 +/- .045	.210 +/- .005	202.57 +/- 1.14	5.34 +/- 0.12
-370	8-1/4	8-5/8	3/16	8.225 +/- .050	.210 +/- .005	208.92 +/- 1.30	5.34 +/- 0.12

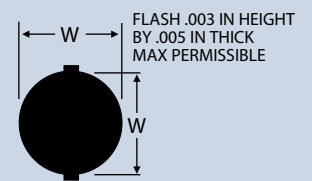
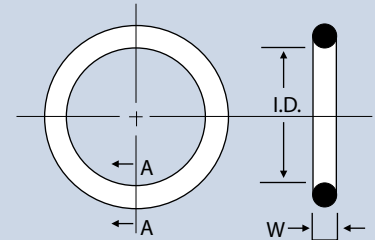

ENLARGED SECTION A.A

PRE-INSTALLATION

Lightly coat the O-Ring with lubricant before installation. Be sure to confirm compatibility of lubricant and O-Ring compound*.

*Refer to the table General Purpose Lubricants for Common O-Ring Elastomers on page 24.

Size Ref. AS 568	Nominal Size (Inches)			Actual Size (Inches)		Actual Size (Millimeters)	
	I.D.	O.D.	W	I.D.	W	I.D.	W
-371	8-1/2	8-7/8	3/16	8.475 +/- .050	.210 +/- .005	215.27 +/- 1.30	5.34 +/- 0.12
-372	8-3/4	9-1/8	3/16	8.725 +/- .050	.210 +/- .005	221.62 +/- 1.30	5.34 +/- 0.12
-373	9	9-3/8	3/16	8.975 +/- .050	.210 +/- .005	227.97 +/- 1.30	5.34 +/- 0.12
-374	9-1/4	9-5/8	3/16	9.225 +/- .055	.210 +/- .005	234.32 +/- 1.40	5.34 +/- 0.12
-375	9-1/2	9-7/8	3/16	9.475 +/- .055	.210 +/- .005	240.67 +/- 1.40	5.34 +/- 0.12
-376	9-3/4	10-1/8	3/16	9.725 +/- .055	.210 +/- .005	247.02 +/- 1.40	5.34 +/- 0.12
-377	10	10-3/8	3/16	9.975 +/- .055	.210 +/- .005	253.37 +/- 1.40	5.34 +/- 0.12
-378	10-1/2	10-7/8	3/16	10.475 +/- .060	.210 +/- .005	266.07 +/- 1.52	5.34 +/- 0.12
-379	11	11-3/8	3/16	10.975 +/- .060	.210 +/- .005	278.77 +/- 1.52	5.34 +/- 0.12
-380	11-1/2	11-7/8	3/16	11.475 +/- .065	.210 +/- .005	291.47 +/- 1.65	5.34 +/- 0.12
-381	12	12-3/8	3/16	11.975 +/- .065	.210 +/- .005	304.17 +/- 1.65	5.34 +/- 0.12
-382	13	13-3/8	3/16	12.975 +/- .065	.210 +/- .005	329.55 +/- 1.65	5.34 +/- 0.12
-383	14	14-3/8	3/16	13.975 +/- .070	.210 +/- .005	354.97 +/- 1.78	5.34 +/- 0.12
-384	15	15-3/8	3/16	14.975 +/- .070	.210 +/- .005	380.37 +/- 1.78	5.34 +/- 0.12
-385	16	16-3/8	3/16	15.955 +/- .075	.210 +/- .005	405.26 +/- 1.90	5.34 +/- 0.12
-386	17	17-3/8	3/16	16.955 +/- .080	.210 +/- .005	430.65 +/- 2.05	5.34 +/- 0.12
-387	18	18-3/8	3/16	17.955 +/- .085	.210 +/- .005	456.06 +/- 2.15	5.34 +/- 0.12
-388	19	19-3/8	3/16	18.955 +/- .090	.210 +/- .005	481.46 +/- 2.25	5.34 +/- 0.12
-389	20	20-3/8	3/16	19.955 +/- .095	.210 +/- .005	506.86 +/- 2.25	5.34 +/- 0.12
-390	21	21-3/8	3/16	20.955 +/- .095	.210 +/- .005	532.26 +/- 2.25	5.34 +/- 0.12
-391	22	22-3/8	3/16	21.955 +/- .100	.210 +/- .005	557.66 +/- 2.55	5.34 +/- 0.12
-392	23	23-3/8	3/16	22.940 +/- .105	.210 +/- .005	582.65 +/- 2.65	5.34 +/- 0.12
-393	24	24-3/8	3/16	23.940 +/- .110	.210 +/- .005	608.10 +/- 2.80	5.34 +/- 0.12
-394	25	25-3/8	3/16	24.940 +/- .115	.210 +/- .005	633.50 +/- 2.90	5.34 +/- 0.12
-395	26	26-3/8	3/16	25.940 +/- .120	.210 +/- .005	658.85 +/- 3.05	5.34 +/- 0.12
-396 thru -424	Call Daemar for Spec Information & Pricing						
-425	4-1/2	5	1/4	4.475 +/- .033	.275 +/- .006	113.67 +/- 0.83	6.98 +/- 0.15
-426	4-5/8	5-1/8	1/4	4.600 +/- .033	.275 +/- .006	116.84 +/- 0.83	6.98 +/- 0.15
-427	4-3/4	5-1/4	1/4	4.725 +/- .033	.275 +/- .006	120.02 +/- 0.83	6.98 +/- 0.15
-428	4-7/8	5-3/8	1/4	4.850 +/- .033	.275 +/- .006	123.19 +/- 0.83	6.98 +/- 0.15
-429	5	5-1/2	1/4	4.975 +/- .037	.275 +/- .006	126.37 +/- 0.93	6.98 +/- 0.15
-430	5-1/8	5-5/8	1/4	5.100 +/- .037	.275 +/- .006	129.54 +/- 0.93	6.98 +/- 0.15
-431	5-1/4	5-3/4	1/4	5.225 +/- .037	.275 +/- .006	132.72 +/- 0.93	6.98 +/- 0.15
-432	5-3/8	5-7/8	1/4	5.350 +/- .037	.275 +/- .006	135.89 +/- 0.93	6.98 +/- 0.15
-433	5-1/2	6	1/4	5.475 +/- .037	.275 +/- .006	139.07 +/- 0.93	6.98 +/- 0.15
-434	5-5/8	6-1/8	1/4	5.600 +/- .037	.275 +/- .006	142.24 +/- 0.93	6.98 +/- 0.15
-435	5-3/4	6-1/4	1/4	5.725 +/- .037	.275 +/- .006	145.42 +/- 0.93	6.98 +/- 0.15

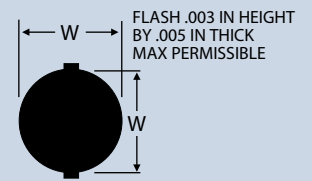
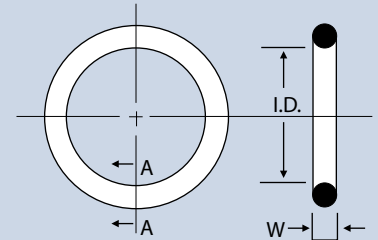

ENLARGED SECTION A.A.

DUROMETER SELECTION

70-durometer hardness should be used wherever possible as it offers the best combination of properties for most O-Ring applications. Softer compounds stretch easier and seal better on rough surfaces. Harder compounds offer greater abrasion resistance and resistance to extrusion.

Size Ref. AS 568	Nominal Size (Inches)			Actual Size (Inches)		Actual Size (Millimeters)	
	I.D.	O.D.	W	I.D.	W	I.D.	W
-436	5-7/8	6-3/8	1/4	5.850 +/- .037	.275 +/- .006	148.59 +/- 0.93	6.98 +/- 0.15
-437	6	6-1/2	1/4	5.975 +/- .037	.275 +/- .006	151.77 +/- 0.93	6.98 +/- 0.15
-438	6-1/4	6-3/4	1/4	6.225 +/- .040	.275 +/- .006	158.12 +/- 1.01	6.98 +/- 0.15
-439	6-1/2	7	1/4	6.475 +/- .040	.275 +/- .006	164.47 +/- 1.01	6.98 +/- 0.15
-440	6-3/4	7-1/4	1/4	6.725 +/- .040	.275 +/- .006	170.82 +/- 1.01	6.98 +/- 0.15
-441	7	7-1/2	1/4	6.975 +/- .040	.275 +/- .006	177.17 +/- 1.01	6.98 +/- 0.15
-442	7-1/4	7-3/4	1/4	7.225 +/- .045	.275 +/- .006	183.52 +/- 1.14	6.98 +/- 0.15
-443	7-1/2	8	1/4	7.475 +/- .045	.275 +/- .006	189.87 +/- 1.14	6.98 +/- 0.15
-444	7-3/4	8-1/4	1/4	7.725 +/- .045	.275 +/- .006	196.22 +/- 1.14	6.98 +/- 0.15
-445	8	8-1/2	1/4	7.975 +/- .045	.275 +/- .006	202.57 +/- 1.14	6.98 +/- 0.15
-446	8-1/2	9	1/4	8.475 +/- .055	.275 +/- .006	215.27 +/- 1.40	6.98 +/- 0.15
-447	9	9-1/2	1/4	8.975 +/- .055	.275 +/- .006	227.97 +/- 1.40	6.98 +/- 0.15
-448	9-1/2	10	1/4	9.475 +/- .055	.275 +/- .006	240.67 +/- 1.40	6.98 +/- 0.15
-449	10	10-1/2	1/4	9.975 +/- .055	.275 +/- .006	253.37 +/- 1.40	6.98 +/- 0.15
-450	10-1/2	11	1/4	10.475 +/- .060	.275 +/- .006	266.07 +/- 1.52	6.98 +/- 0.15
-451	11	11-1/2	1/4	10.975 +/- .060	.275 +/- .006	278.77 +/- 1.52	6.98 +/- 0.15
-452	11-1/2	12	1/4	11.475 +/- .060	.275 +/- .006	291.47 +/- 1.52	6.98 +/- 0.15
-453	12	12-1/2	1/4	11.975 +/- .060	.275 +/- .006	304.17 +/- 1.52	6.98 +/- 0.15
-454	12-1/2	13	1/4	12.475 +/- .060	.275 +/- .006	316.87 +/- 1.52	6.98 +/- 0.15
-455	13	13-1/2	1/4	12.975 +/- .060	.275 +/- .006	329.57 +/- 1.52	6.98 +/- 0.15
-456	13-1/2	14	1/4	13.475 +/- .070	.275 +/- .006	342.27 +/- 1.78	6.98 +/- 0.15
-457	14	14-1/2	1/4	13.975 +/- .070	.275 +/- .006	354.97 +/- 1.78	6.98 +/- 0.15
-458	14-1/2	15	1/4	14.475 +/- .070	.275 +/- .006	367.67 +/- 1.78	6.98 +/- 0.15
-459	15	15-1/2	1/4	14.975 +/- .070	.275 +/- .006	380.37 +/- 1.78	6.98 +/- 0.15
-460	15-1/2	16	1/4	15.475 +/- .070	.275 +/- .006	393.07 +/- 1.78	6.98 +/- 0.15
-461	16	16-1/2	1/4	15.955 +/- .075	.275 +/- .006	405.26 +/- 1.90	6.98 +/- 0.15
-462	16-1/2	17	1/4	16.455 +/- .075	.275 +/- .006	417.96 +/- 1.90	6.98 +/- 0.15
-463	17	17-1/2	1/4	16.955 +/- .080	.275 +/- .006	430.66 +/- 2.05	6.98 +/- 0.15
-464	17-1/2	18	1/4	17.455 +/- .085	.275 +/- .006	443.36 +/- 2.15	6.98 +/- 0.15
-465	18	18-1/2	1/4	17.955 +/- .085	.275 +/- .006	456.06 +/- 2.15	6.98 +/- 0.15
-466	18-1/2	19	1/4	18.455 +/- .085	.275 +/- .006	468.76 +/- 2.15	6.98 +/- 0.15
-467	19	19-1/2	1/4	18.955 +/- .090	.275 +/- .006	481.46 +/- 2.25	6.98 +/- 0.15
-468	19-1/2	20	1/4	19.455 +/- .090	.275 +/- .006	494.16 +/- 2.25	6.98 +/- 0.15
-469	20	20-1/2	1/4	19.955 +/- .090	.275 +/- .006	506.86 +/- 2.45	6.98 +/- 0.15
-470	21	21-1/2	1/4	20.955 +/- .090	.275 +/- .006	532.26 +/- 2.45	6.98 +/- 0.15
-471	22	22-1/2	1/4	21.955 +/- .100	.275 +/- .006	557.66 +/- 2.55	6.98 +/- 0.15
-472	23	23-1/2	1/4	22.940 +/- .105	.275 +/- .006	582.65 +/- 2.65	6.98 +/- 0.15
-473	24	24-1/2	1/4	23.940 +/- .110	.275 +/- .006	608.10 +/- 2.80	6.98 +/- 0.15
-474	25	25-1/2	1/4	24.940 +/- .115	.275 +/- .006	633.50 +/- 2.90	6.98 +/- 0.15
-475	26	26-1/2	1/4	25.940 +/- .120	.275 +/- .006	658.85 +/- 3.05	6.98 +/- 0.15

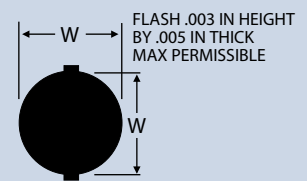
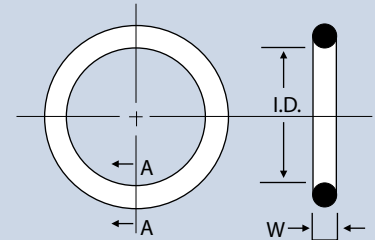

ENLARGED SECTION A.A.

LUBRICANTS

Lubricants should be selected on the following basis:

- 1) the type of material of which the O-Ring is constructed.
- 2) the type of service to which the O-Ring will be subjected.

Do not use a lubricant composed of the same base material as the O-Ring being lubricated.

Size Ref. AS 568	Tube Size O.D.	Inch Standard		Vol. Cu. In.	Metric Standard		Vol. Cu. In.
		I.D.	W		I.D.	W	
-901	3/32	.185 +/- .005	.056 +/- .003	0.0019	4.70 +/- 0.13	1.42 +/- 0.08	0.031
-902	1/8	.239 +/- .005	.064 +/- .003	0.0031	6.07 +/- 0.13	1.63 +/- 0.08	0.051
-903	3/16	.301 +/- .005	.064 +/- .003	0.0037	7.65 +/- 0.13	1.63 +/- 0.08	0.061
-904	1/4	.351 +/- .005	.072 +/- .003	0.0054	8.92 +/- 0.13	1.83 +/- 0.08	0.088
-905	5/16	.414 +/- .005	.072 +/- .003	0.0062	10.52 +/- 0.13	1.83 +/- 0.08	0.102
-906	3/8	.468 +/- .005	.078 +/- .003	0.0082	11.89 +/- 0.13	1.98 +/- 0.08	0.134
-907	7/16	.530 +/- .005	.082 +/- .003	0.0102	13.46 +/- 0.18	2.08 +/- 0.08	0.167
-908	1/2	.644 +/- .009	.087 +/- .003	0.0137	16.36 +/- 0.23	2.21 +/- 0.08	0.225
-909	9/16	.706 +/- .009	.097 +/- .003	0.0186	17.94 +/- 0.23	2.46 +/- 0.08	0.305
-910	5/8	.755 +/- .009	.097 +/- .003	0.0198	19.18 +/- 0.23	2.46 +/- 0.08	0.324
-911	11/16	.863 +/- .009	.116 +/- .004	0.0325	21.92 +/- .023	2.95 +/- 0.10	0.533
-912	3/4	.924 +/- .009	.116 +/- .004	0.0345	23.47 +/- 0.23	2.95 +/- 0.10	0.565
-913	13/16	.986 +/- .010	.116 +/- .004	0.0366	25.04 +/- 0.25	2.95 +/- 0.10	0.600
-914	7/8	1.047 +/- .010	.116 +/- .004	0.0386	26.60 +/- 0.25	2.95 +/- 0.10	0.633
-916	1	1.171 +/- .010	.116 +/- .004	0.0427	29.75 +/- 0.25	2.95 +/- 0.10	0.700
-918	1-1/8	1.355 +/- .012	.116 +/- .004	0.0488	34.42 +/- 0.30	2.95 +/- 0.10	0.800
-920	1-1/4	1.475 +/- .014	.118 +/- .004	0.0547	37.46 +/- 0.35	3.00 +/- 0.10	0.896
-924	1-1/2	1.720 +/- .014	.118 +/- .004	0.0631	43.68 +/- 0.35	3.00 +/- 0.10	1.034
-928	1-3/4	2.090 +/- .018	.118 +/- .004	0.0759	53.09 +/- 0.45	3.00 +/- 0.10	1.244
-932	2	2.337 +/- .018	.118 +/- .004	0.0843	59.36 +/- 0.45	3.00 +/- 0.10	1.381

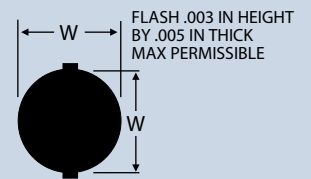
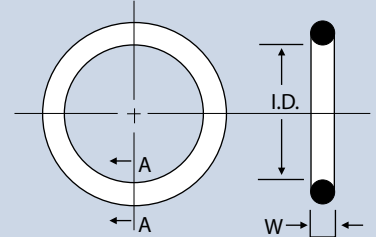

ENLARGED SECTION A.A.

DESIGN NOTES:

Durometer: O-Ring sizes for Boss Tube Fittings are available in both 70 & 90 Durometer.

Application: providing a seal for straight-thread tube fittings on a boss.

Numbering System: The two digits after the -9 represent the Tube Size O.D. in 16ths of an inch. For example -905 is sized for a Tube O.D. of 5/16". The one exception is for -901 where the Tube Size O.D. is 3/32".

I.D.	W	I.D.	W	I.D.	W	I.D.	W
1.50	1.00	5.00	1.50	8.90	1.90	12.50	1.50
1.78	1.02	5.00	1.60	8.90	2.70	12.50	2.00
1.80	1.00	5.00	2.00	9.00	1.00	12.50	2.50
1.80	1.50	5.00	2.50	9.00	1.50	12.60	2.40
1.85	1.50	5.00	3.00	9.00	2.00	12.70	2.62
2.00	1.00	5.10	1.60	9.00	2.50	13.00	1.00
2.00	1.50	5.30	2.40	9.00	3.00	13.00	1.50
2.20	1.60	5.36	0.81	9.10	1.60	13.00	2.00
2.40	1.90	5.50	2.40	9.20	3.50	13.00	2.50
2.50	1.00	5.60	2.40	9.30	2.40	13.00	3.00
2.50	1.50	5.70	1.90	9.50	1.50	13.10	1.60
2.50	2.00	6.00	1.00	9.50	2.50	13.10	2.62
2.54	0.97	6.00	1.50	9.53	2.92	13.25	1.50
2.60	1.90	6.00	2.00	9.60	2.40	13.30	2.40
2.60	2.00	6.00	2.50	9.92	2.62	13.50	2.50
2.70	1.00	6.00	3.00	10.00	1.00	13.60	2.40
2.75	1.60	6.00	4.00	10.00	1.50	13.60	2.70
2.80	1.50	6.10	1.60	10.00	2.00	14.00	1.00
3.00	1.00	6.30	2.40	10.00	2.50	14.00	1.50
3.00	1.50	6.35	1.78	10.00	3.00	14.00	2.00
3.00	2.00	6.40	1.90	10.10	1.60	14.00	2.50
3.10	1.60	6.50	1.00	10.30	2.40	14.00	3.00
3.17	1.78	6.50	1.50	10.50	1.50	14.00	3.50
3.25	1.27	6.50	3.00	10.50	2.00	14.10	1.60
3.30	1.00	6.60	2.40	10.50	2.70	14.30	2.40
3.30	2.40	6.75	1.78	10.60	2.40	14.60	2.40
3.40	1.90	7.00	1.50	11.00	1.00	15.00	1.00
3.50	1.00	7.00	2.00	11.00	1.50	15.00	1.50
3.50	1.20	7.00	2.50	11.00	2.00	15.00	2.00
3.50	1.50	7.00	3.00	11.00	2.50	15.00	2.50
3.60	2.40	7.10	1.60	11.00	3.00	15.00	3.00
3.70	1.90	7.20	1.00	11.00	3.50	15.00	3.50
3.80	1.25	7.20	1.90	11.00	4.00	15.08	2.62
3.91	1.27	7.30	2.40	11.10	1.60	15.10	1.60
4.00	1.00	7.50	1.50	11.11	1.78	15.10	2.70
4.00	1.50	7.60	2.40	11.30	2.40	15.30	2.40
4.00	2.00	7.60	4.00	11.50	1.00	15.60	2.40
4.10	1.60	7.94	1.78	11.50	3.00	15.88	2.62
4.20	1.90	8.00	1.00	11.60	2.40	16.00	1.50
4.30	2.40	8.00	1.50	11.91	2.62	16.00	2.00
4.32	1.19	8.00	1.90	12.00	1.00	16.00	2.50
4.47	1.27	8.00	2.00	12.00	1.50	16.00	3.00
4.50	1.50	8.00	2.40	12.00	2.00	16.00	3.50
4.60	2.00	8.00	2.50	12.00	2.50	16.00	5.00
4.60	2.40	8.00	3.00	12.00	3.00	16.10	1.60
4.60	2.50	8.00	3.50	12.00	3.50	16.30	2.40
4.70	1.60	8.10	1.60	12.10	1.60	16.60	2.40
4.76	1.78	8.30	2.40	12.10	2.70	16.90	2.70
4.90	1.90	8.60	2.40	12.30	2.40	17.00	1.00
5.00	1.00	8.73	1.78	12.40	2.18	17.00	1.50

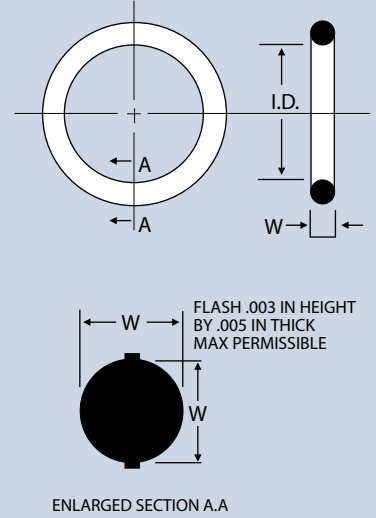

O-RING STRETCH

As a general rule of thumb the groove I.D. should stretch the O-Ring I.D. by between 1 to 3% and by no more than 5%. Exceeding this limit may over stress the material (see Gow-Joule Effect on page 36).

I.D.	W	I.D.	W	I.D.	W	I.D.	W
17.00	2.00	21.00	4.00	25.50	3.00	31.50	3.00
17.00	2.50	21.10	1.60	25.60	2.40	31.60	2.40
17.00	3.00	21.30	2.40	25.80	3.53	32.00	1.00
17.10	1.60	21.30	3.60	26.00	1.50	32.00	2.00
17.30	2.40	21.50	2.40	26.00	2.00	32.00	2.50
17.46	2.62	21.50	3.00	26.00	2.50	32.00	3.00
17.50	2.00	21.60	2.40	26.00	4.00	32.00	3.50
17.50	3.50	22.00	1.00	26.00	5.00	32.00	4.00
17.60	2.40	22.00	1.50	26.20	3.00	32.00	5.00
17.86	2.62	22.00	2.00	26.20	3.60	32.10	1.60
18.00	1.50	22.00	2.50	26.50	3.00	32.50	3.00
18.00	2.00	22.00	3.00	27.00	1.50	32.50	3.60
18.00	2.50	22.10	1.60	27.00	2.00	33.00	3.00
18.00	3.00	22.20	3.00	27.00	2.50	34.00	2.50
18.00	3.50	22.22	2.62	27.00	3.00	34.00	4.00
18.00	4.00	22.30	2.40	27.00	3.50	34.10	3.60
18.10	1.60	22.50	2.00	27.00	4.00	34.20	3.00
18.30	2.40	22.50	3.00	27.10	1.60	34.50	3.00
18.30	3.60	22.60	2.40	27.30	2.40	34.60	2.40
18.40	2.70	23.00	1.50	27.30	2.70	35.00	2.00
18.60	2.40	23.00	2.00	27.50	3.00	35.00	3.00
18.60	2.70	23.00	2.50	27.60	2.40	35.00	3.50
19.00	1.50	23.00	3.00	27.80	3.60	35.00	4.00
19.00	2.00	23.00	3.50	28.00	1.50	35.10	1.60
19.00	2.50	23.00	3.60	28.00	2.00	35.20	5.70
19.00	3.00	23.00	4.00	28.00	2.50	35.50	3.00
19.00	3.50	23.30	2.40	28.00	3.00	35.60	3.60
19.10	1.60	23.50	3.00	28.00	4.00	36.00	2.00
19.20	3.00	23.60	2.40	28.50	2.50	36.00	2.50
19.30	2.40	23.81	2.62	28.50	3.00	36.00	3.00
19.50	1.50	24.00	1.50	29.00	1.50	36.00	5.00
19.50	3.00	24.00	2.00	29.00	2.00	36.20	3.00
19.60	2.40	24.00	2.50	29.00	2.50	36.20	5.70
19.80	3.60	24.00	3.00	29.00	3.50	36.27	1.78
20.00	1.50	24.00	3.50	29.00	4.00	36.50	2.40
20.00	2.00	24.20	3.00	29.10	1.60	36.50	3.00
20.00	2.50	24.30	2.40	29.20	3.00	37.00	2.00
20.00	4.00	24.40	3.10	29.30	3.60	37.00	2.50
20.00	3.00	24.50	3.00	29.40	2.70	37.00	3.00
20.00	3.50	24.60	2.40	29.50	1.50	37.00	3.50
20.10	1.60	24.60	3.00	29.50	3.00	37.10	1.60
20.30	2.40	24.60	3.60	29.60	2.40	37.20	3.00
20.50	2.40	25.00	2.00	30.00	1.50	37.20	5.70
20.64	2.62	25.00	2.40	30.00	2.50	37.30	3.60
21.00	1.00	25.00	2.50	30.00	3.00	37.50	3.00
21.00	1.50	25.00	3.00	30.00	4.00	37.60	2.40
21.00	2.00	25.00	3.50	30.50	3.00	38.00	1.50
21.00	2.50	25.00	4.00	30.80	3.60	38.00	2.50
21.00	3.00	25.10	1.60	31.00	2.50	38.00	3.00
21.00	3.50	25.30	2.40	31.00	3.00	38.00	3.50

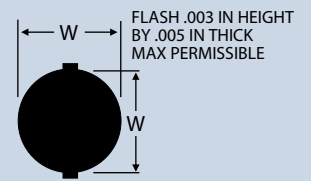
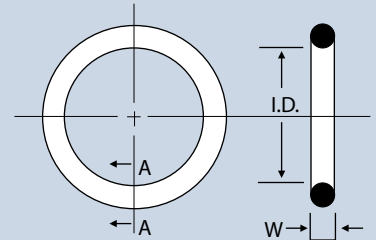

ENLARGED SECTION A.A

GROOVE DESIGN

Groove depth should be less than the cross sectional width of the O-Ring. The groove width should be wider than the cross sectional width of the O-Ring in order to accommodate O-Ring compression.

I.D.	W	I.D.	W	I.D.	W	I.D.	W
38.00	4.00	49.60	2.40	59.00	5.00	69.00	5.70
39.00	3.00	50.00	2.50	59.20	5.70	69.20	5.70
40.00	2.00	50.00	3.00	59.50	3.00	69.50	3.00
40.00	4.00	50.00	4.00	59.60	2.40	69.60	2.40
41.20	5.70	50.00	5.00	59.70	5.70	69.85	3.53
42.00	3.00	50.50	3.00	60.00	3.00	70.00	3.00
42.00	3.50	50.80	3.53	60.00	4.00	70.00	4.00
42.00	4.00	51.00	2.50	60.00	5.00	70.00	5.00
42.20	3.00	51.00	3.00	60.32	3.53	70.20	5.70
42.50	3.00	51.00	4.00	61.00	3.00	71.00	3.00
42.86	3.53	51.00	5.00	61.00	3.50	71.20	5.70
43.00	3.00	51.20	5.70	61.00	4.00	71.44	3.53
43.00	4.00	51.60	2.40	61.00	5.00	72.00	3.00
43.40	3.60	52.00	3.00	61.20	5.70	72.00	4.00
44.00	2.50	52.00	3.50	61.60	2.40	72.00	5.00
44.00	3.00	52.00	4.00	61.90	3.53	72.20	5.70
44.20	3.00	52.00	5.00	62.00	3.00	73.00	3.00
44.20	5.70	52.20	5.70	62.00	4.00	73.00	5.00
44.45	3.53	52.39	3.53	62.00	4.50	73.03	3.53
44.50	3.00	52.50	5.70	62.00	5.00	74.00	5.70
44.60	2.40	53.00	2.50	62.00	5.70	74.30	2.62
45.00	2.00	53.00	4.00	62.20	5.70	74.20	5.70
45.00	3.00	53.00	5.00	63.00	3.00	74.50	3.00
45.00	3.50	53.97	3.53	63.00	4.00	74.61	3.53
45.00	4.00	54.00	3.00	63.00	5.00	75.00	4.00
45.00	5.00	54.00	4.00	63.50	3.53	75.00	5.00
45.20	5.70	54.00	5.00	64.00	3.00	76.00	3.00
46.00	3.00	54.20	5.70	64.00	3.50	77.00	3.50
46.00	4.00	54.20	3.00	64.00	4.00	77.00	4.00
46.00	5.00	54.60	2.40	64.00	5.00	77.00	5.00
46.04	3.53	55.00	3.50	64.00	5.70	77.20	5.70
47.00	2.50	55.00	4.00	64.20	5.70	77.50	2.62
47.00	3.00	55.00	5.00	64.50	3.00	78.00	3.00
47.00	4.00	55.20	5.70	64.60	2.40	78.00	5.00
47.00	5.00	55.56	3.53	65.00	3.00	79.00	1.78
47.20	5.70	56.00	3.00	65.00	4.00	79.00	3.00
47.60	2.40	56.00	4.00	65.00	5.00	79.00	5.70
47.63	3.53	56.00	5.00	65.10	3.53	79.20	5.70
48.00	2.00	57.00	3.00	66.00	3.00	79.50	3.00
48.00	3.00	57.00	4.00	66.00	4.00	79.77	5.33
48.00	3.50	57.00	5.00	66.00	5.00	80.00	3.00
48.00	4.00	57.15	3.53	66.68	3.53	80.00	3.50
48.00	5.00	57.20	5.70	67.00	3.00	80.00	4.00
49.00	2.50	57.60	2.40	67.00	5.00	80.00	5.00
49.00	3.00	58.00	3.00	67.20	5.70	80.60	2.62
49.00	4.00	58.00	3.50	67.60	2.40	81.00	5.00
49.00	5.00	58.00	5.00	68.00	3.00	82.00	3.00
49.20	3.53	58.74	3.53	68.26	3.53	82.20	5.70
49.20	5.70	59.00	3.00	69.00	3.00	83.00	3.00
49.50	3.00	59.00	4.00	69.00	3.50	83.00	5.00

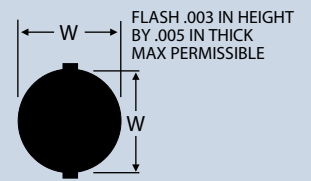
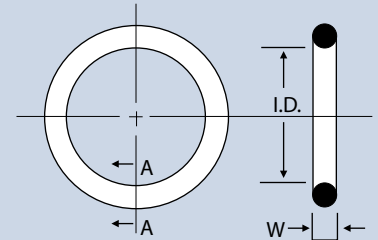

ENLARGED SECTION A.A

THE GOW-JOULE EFFECT

This effect can occur when elastomers are subjected to heat or friction. It is characterized by the tendency of elastomers under tension to shrink when heated rather than expand as is most commonly believed. This effect sets up a destructive situation where as heat and friction build up the O-Ring shrinks thus causing more heat and friction.

The Gow-Joule Effect can be avoided by installing the O-Ring in compression rather than tension.

I.D.	W	I.D.	W	I.D.	W	I.D.	W
83.80	2.62	110.00	3.00	139.20	5.70	169.00	3.50
84.00	5.70	110.00	3.50	139.50	3.00	169.10	8.40
84.20	5.70	112.00	5.00	139.70	5.33	169.30	5.70
84.50	3.00	114.00	3.00	140.00	3.00	169.50	3.00
85.00	2.50	114.00	5.70	140.00	5.00	170.00	3.00
85.00	3.00	114.20	5.70	142.00	4.00	170.00	5.00
85.00	4.00	114.50	3.00	143.00	5.00	171.00	5.00
85.00	5.00	114.70	6.99	144.10	8.40	172.00	3.00
85.34	1.78	115.00	4.00	144.20	5.70	172.00	5.00
86.00	3.00	117.00	5.00	144.50	3.00	173.00	3.50
87.00	5.00	117.48	5.33	145.00	3.00	174.00	3.00
87.20	5.70	118.00	3.00	145.00	5.00	174.10	8.40
89.00	5.70	119.00	5.70	146.00	3.00	174.30	5.70
89.20	5.70	119.30	5.70	146.05	5.33	174.50	3.00
89.50	3.00	119.50	3.00	148.00	3.00	174.60	6.99
89.69	5.33	120.00	3.00	149.10	8.40	175.00	5.00
90.00	4.00	120.00	5.00	149.30	5.70	177.00	5.00
90.00	5.00	120.65	5.33	149.50	3.00	178.00	5.00
91.70	1.78	122.00	3.00	150.00	5.00	179.10	8.40
92.20	5.70	122.00	4.00	152.00	3.00	179.30	5.70
93.00	4.00	123.83	5.33	152.00	5.00	180.00	5.00
94.20	5.70	124.00	4.00	153.00	5.00	181.00	6.99
94.50	3.00	124.30	5.70	154.00	5.00	182.00	5.00
95.00	5.00	124.50	3.00	154.10	8.40	183.00	5.00
97.20	5.70	125.00	5.00	154.30	5.70	184.10	8.40
99.20	5.70	125.30	5.70	154.50	3.00	184.30	5.70
99.50	3.00	126.00	3.00	155.00	4.00	184.50	3.00
100.00	2.00	126.00	4.00	155.00	5.00	185.00	5.00
100.00	3.00	126.50	3.00	155.60	6.99	187.30	6.99
100.00	3.50	127.00	5.33	156.00	3.00	188.00	5.00
100.00	4.00	128.00	3.00	156.00	5.00	189.10	8.40
100.00	5.00	128.00	5.00	157.00	3.50	189.03	5.70
100.00	5.33	129.20	5.70	158.00	5.00	189.50	3.00
102.00	3.00	129.50	3.00	159.10	8.40	193.70	6.99
102.00	5.00	130.00	3.00	159.30	5.70	194.10	8.40
104.00	4.00	130.00	5.00	159.50	3.00	194.20	5.70
104.20	5.70	130.18	5.33	159.50	6.99	194.50	3.00
104.40	1.78	132.00	3.00	160.00	4.00	195.00	5.00
104.50	3.00	132.00	3.50	160.00	5.00	197.00	5.00
105.00	3.00	132.20	5.70	161.30	5.33	199.10	8.40
105.00	3.50	133.20	5.70	161.90	6.99	199.30	5.70
105.00	5.00	133.35	5.33	164.10	8.40	199.50	3.00
106.00	3.00	134.00	3.00	164.30	5.70	200.00	3.00
107.00	5.00	134.20	5.70	164.50	3.00	200.00	5.00
108.00	3.00	134.50	6.99	165.00	5.00	200.00	6.99
108.00	5.00	135.00	5.00	166.70	6.99	202.00	5.00
109.20	5.70	136.53	5.33	167.00	5.00	204.10	8.40
109.50	3.00	138.00	4.00	168.00	3.50	204.20	5.70
109.54	5.33	138.00	5.00	168.00	5.70	204.50	3.00
110.00	2.50	139.00	4.20	168.30	6.99	205.00	5.00

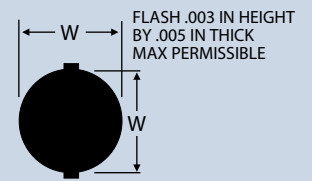
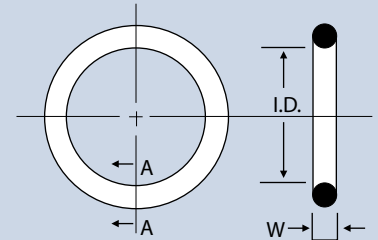

SEALING PRESSURE

Created by compression of the seal between the mating surfaces of the gland and external forces such as the pressure exerted by the fluid being sealed. Low-pressure applications (below 100 psi), rely on the O-Ring's ability to deform (material hardness) and the surface finish of the seal and the gland. In high-pressure environments, system pressure compresses the seal and thus factors such as seal material hardness, cross sectional width and gap clearance are more important than seal and gland surface finishes.

I.D.	W
208.92	6.99
209.10	8.40
209.20	5.70
209.50	3.00
210.00	5.00
215.00	5.00
219.10	8.40
219.30	5.70
219.50	3.00
220.00	5.00
221.62	6.99
222.00	5.00
225.00	5.00
229.10	8.40
229.30	5.70
230.00	3.00
230.00	5.00
234.10	8.40
234.32	6.99
235.00	5.00

I.D.	W
238.00	5.00
239.10	8.40
239.30	5.70
240.00	5.00
245.00	5.00
247.00	6.99
249.10	8.40
249.30	5.70
249.50	3.00
250.00	5.00
255.00	5.00
259.30	5.70
260.00	5.00
265.00	5.00
269.30	5.70
270.00	5.00
272.00	5.00
272.40	6.99
275.00	5.00
279.30	5.70

I.D.	W
280.00	5.00
285.00	5.00
285.10	6.99
189.30	5.70
290.00	5.00
295.00	5.00
299.30	5.70
300.00	5.00
319.30	5.70
329.30	5.70

I.D.	W
339.30	5.70
359.30	5.70
379.30	5.70
399.30	5.70
419.30	5.70
439.30	5.70
449.20	5.70
459.30	5.70
479.30	5.70
499.30	5.70

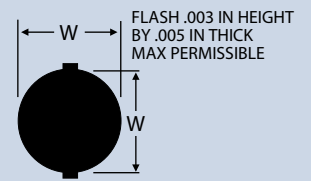
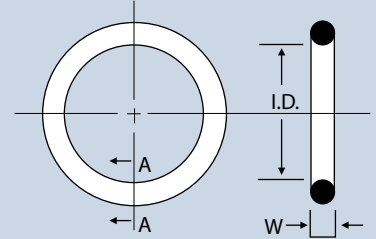

ENLARGED SECTION A.A.

ASK THE EXPERTS

If you can't find the answer to your questions in our catalogue or if you have application specific technical questions please contact your local Daemar sales representative.

Back-up rings are washer-like devices that are used to prevent a seal from extruding through any gaps while under pressure. These seals are installed in the downstream side of the gland. Back-up rings are not seals themselves, but are usually used in conjunction with O-rings in high-pressure applications (over 1500 psi) for support or as spacers. Typical applications include hydraulic cylinders and high-pressure hydraulic systems, and high-pressure valves. In many applications it is best to use two back-up rings; one above the o-ring and one below, to provide maximum support.

Back-up rings are available in two distinct face design configurations – a flat, washer style where the ring has two flat, parallel surfaces, much like a washer and a contoured style where one face is straight and the opposite face is curved or contoured. The contoured face is the one that comes in contact with the o-ring, providing better grip and support.

FLAT/WASHER STYLE:

Metric and Standard

Configuration: Solid, Split, Spiral

Materials: PTFE, URETHANE, NYLON

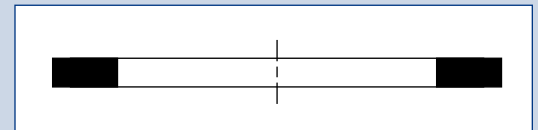

CONTOURED STYLE: (“PARBACK” STYLE):

Material: Nitrile 90 Durometer, Fluoroelastomer 90 Durometer

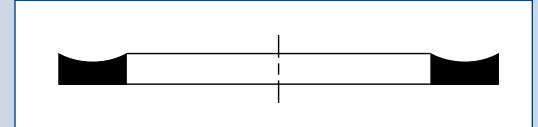

574 STYLE ("STANDARD ONLY")

Molded of a 90A Durometer Buna-N Rubber. The 574 Style dished Cross section back-up rings provide excellent extrusion resistance. Stretched for installation, they return quickly to their original size for easy installation.

PLEASE NOTE: Sizes (Dash NO.) Corresponds to standard o-ring numbers.

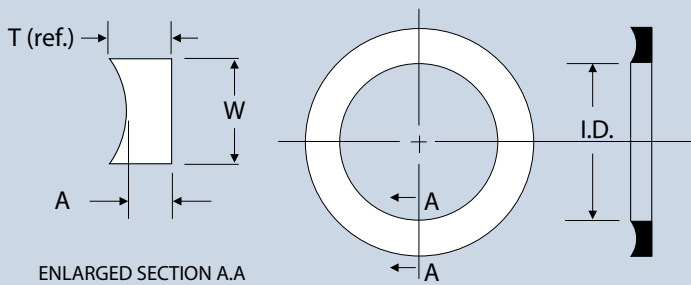

Part Numbers	T(ref.)	A
574-004 thru 574-050	.049	.045 +/- .003
574-102 thru 574-178	.053	.045 +/- .003
574-201 thru 574-284	.050	.040 +/- .003
574-309 thru 574-395	.076	.060 +/- .004
574-425 thru 574-475	.117	.096 +/- .005

Back-Up Rings Style 574 Buna-N				
Part Number	I.D.	Tol. +/-	W	Tol. +/-
574-004	0.096	0.005	0.053	0.003
574-005	0.127	0.005	0.053	0.003
574-006	0.14	0.005	0.053	0.003
574-007	0.171	0.005	0.053	0.003
574-008	0.202	0.005	0.053	0.003
574-009	0.234	0.005	0.053	0.003
574-010	0.265	0.005	0.053	0.003
574-011	0.327	0.005	0.053	0.003
574-012	0.39	0.005	0.053	0.003
574-013	0.455	0.005	0.053	0.003
574-014	0.518	0.005	0.053	0.003
574-015	0.58	0.005	0.053	0.003
574-016	0.643	0.009	0.053	0.003
574-017	0.705	0.009	0.053	0.003
574-018	0.768	0.009	0.053	0.003
574-019	0.83	0.009	0.053	0.003
574-020	0.893	0.009	0.053	0.003

Back-Up Rings Style 574 Buna-N				
Part Number	I.D.	Tol. +/-	W	Tol. +/-
574-021	0.955	0.009	0.053	0.003
574-022	1.018	0.01	0.053	0.003
574-023	1.08	0.01	0.053	0.003
574-024	1.143	0.01	0.053	0.003
574-025	1.205	0.011	0.053	0.003
574-026	1.268	0.011	0.053	0.003
574-027	1.33	0.011	0.053	0.003
574-028	1.393	0.013	0.053	0.003
574-029	1.518	0.013	0.053	0.003
574-030	1.643	0.013	0.053	0.003
574-031	1.768	0.015	0.053	0.003
574-032	1.893	0.015	0.053	0.003
574-033	2.018	0.018	0.053	0.003
574-034	2.143	0.018	0.053	0.003
574-035	2.268	0.018	0.053	0.003
574-036	2.393	0.018	0.053	0.003
574-037	2.519	0.018	0.053	0.003

Back-Up Rings Style 574 Buna-N

Part Number	I.D.	Tol. +/-	W	Tol. +/-
574-038	2.643	0.018	0.053	0.003
574-039	2.768	0.02	0.053	0.003
574-040	2.893	0.02	0.053	0.003
574-041	3.018	0.024	0.053	0.003
574-042	3.268	0.024	0.053	0.003
574-043	3.518	0.024	0.053	0.003
574-044	3.768	0.027	0.053	0.003
574-045	4.018	0.027	0.053	0.003
574-046	4.268	0.03	0.053	0.003
574-047	4.518	0.03	0.053	0.003
574-048	4.768	0.03	0.053	0.003
574-049	5.018	0.037	0.053	0.003
574-050	5.268	0.037	0.053	0.003
574-102	0.077	0.005	0.086	0.003
574-103	0.109	0.005	0.086	0.003
574-104	0.14	0.005	0.086	0.003
574-105	0.171	0.005	0.086	0.003
574-106	0.202	0.005	0.086	0.003
574-107	0.234	0.005	0.086	0.003
574-108	0.265	0.005	0.086	0.003
574-109	0.327	0.005	0.086	0.003
574-110	0.39	0.005	0.086	0.003
574-111	0.452	0.005	0.086	0.003
574-112	0.515	0.007	0.086	0.003
574-113	0.577	0.007	0.086	0.003
574-114	0.64	0.009	0.086	0.003
574-115	0.702	0.009	0.086	0.003
574-116	0.765	0.009	0.086	0.003
574-117	0.831	0.01	0.086	0.003
574-118	0.893	0.01	0.086	0.003
574-119	0.956	0.01	0.086	0.003
574-120	1.018	0.01	0.086	0.003
574-121	1.081	0.01	0.086	0.003
574-122	1.143	0.01	0.086	0.003

Back-Up Rings Style 574 Buna-N

Part Number	I.D.	Tol. +/-	W	Tol. +/-
574-123	1.206	0.012	0.086	0.003
574-124	1.268	0.012	0.086	0.003
574-125	1.331	0.012	0.086	0.003
574-126	1.393	0.012	0.086	0.003
574-127	1.456	0.012	0.086	0.003
574-128	1.518	0.012	0.086	0.003
574-129	1.581	0.015	0.086	0.003
574-130	1.643	0.015	0.086	0.003
574-131	1.706	0.015	0.086	0.003
574-132	1.768	0.015	0.086	0.003
574-133	1.831	0.015	0.086	0.003
574-134	1.893	0.015	0.086	0.003
574-135	1.956	0.017	0.086	0.003
574-136	2.018	0.017	0.086	0.003
574-137	2.081	0.017	0.086	0.003
574-138	2.143	0.017	0.086	0.003
574-139	2.206	0.017	0.086	0.003
574-140	2.268	0.017	0.086	0.003
574-141	2.331	0.02	0.086	0.003
574-142	2.393	0.02	0.086	0.003
574-143	2.456	0.02	0.086	0.003
574-144	2.528	0.02	0.086	0.003
574-145	2.518	0.02	0.086	0.003
574-146	2.643	0.02	0.086	0.003
574-147	2.706	0.022	0.086	0.003
574-148	2.768	0.022	0.086	0.003
574-149	2.831	0.022	0.086	0.003
574-150	2.893	0.022	0.086	0.003
574-151	3.018	0.024	0.086	0.003
574-152	3.268	0.024	0.086	0.003
574-153	3.518	0.024	0.086	0.003
574-154	3.768	0.028	0.086	0.003
574-155	4.018	0.028	0.086	0.003
574-156	4.268	0.03	0.086	0.003

Back-Up Rings Style 574 Buna-N

Part Number	I.D.	Tol. +/-	W	Tol. +/-
574-157	4.518	0.03	0.086	0.003
574-158	4.768	0.03	0.086	0.003
574-159	5.018	0.035	0.086	0.003
574-160	5.268	0.035	0.086	0.003
574-161	5.518	0.035	0.086	0.003
574-162	5.768	0.035	0.086	0.003
574-163	6.018	0.035	0.086	0.003
574-164	6.268	0.04	0.086	0.003
574-165	6.518	0.04	0.086	0.003
574-166	6.768	0.04	0.086	0.003
574-167	7.018	0.04	0.086	0.003
574-168	7.268	0.045	0.086	0.003
574-169	7.518	0.045	0.086	0.003
574-170	7.768	0.045	0.086	0.003
574-171	8.018	0.045	0.086	0.003
574-172	8.268	0.05	0.086	0.003
574-173	8.518	0.05	0.086	0.003
574-174	8.768	0.05	0.086	0.003
574-175	9.018	0.05	0.086	0.003
574-176	9.268	0.05	0.086	0.003
574-177	9.518	0.055	0.086	0.003
574-178	9.768	0.055	0.086	0.003
574-201	0.202	0.005	0.118	0.004
574-202	0.265	0.005	0.118	0.004
574-203	0.327	0.005	0.118	0.004
574-204	0.39	0.005	0.118	0.004
574-205	0.455	0.005	0.118	0.004
574-206	0.518	0.007	0.118	0.004
574-207	0.58	0.007	0.118	0.004
574-208	0.643	0.009	0.118	0.004
574-209	0.705	0.009	0.118	0.004
574-210	0.765	0.01	0.118	0.004
574-211	0.828	0.01	0.118	0.004
574-212	0.891	0.01	0.118	0.004

Back-Up Rings Style 574 Buna-N

Part Number	I.D.	Tol. +/-	W	Tol. +/-
574-213	0.953	0.01	0.118	0.004
574-214	1.016	0.01	0.118	0.004
574-215	1.078	0.01	0.118	0.004
574-216	1.141	0.012	0.118	0.004
574-217	1.203	0.012	0.118	0.004
574-218	1.266	0.012	0.118	0.004
574-219	1.334	0.012	0.118	0.004
574-220	1.397	0.012	0.118	0.004
574-221	1.459	0.012	0.118	0.004
574-222	1.522	0.015	0.118	0.004
574-223	1.647	0.015	0.118	0.004
574-224	1.772	0.015	0.118	0.004
574-225	1.897	0.018	0.118	0.004
574-226	2.022	0.018	0.118	0.004
574-227	2.147	0.018	0.118	0.004
574-228	2.272	0.02	0.118	0.004
574-229	2.397	0.02	0.118	0.004
574-230	2.522	0.02	0.118	0.004
574-231	2.631	0.02	0.118	0.004
574-232	2.756	0.024	0.118	0.004
574-233	2.881	0.024	0.118	0.004
574-234	3.006	0.024	0.118	0.004
574-235	3.131	0.024	0.118	0.004
574-236	3.256	0.024	0.118	0.004
574-237	3.381	0.024	0.118	0.004
574-238	3.506	0.024	0.118	0.004
574-239	3.631	0.028	0.118	0.004
574-240	3.756	0.028	0.118	0.004
574-241	3.881	0.028	0.118	0.004
574-242	4.006	0.028	0.118	0.004
574-243	4.131	0.028	0.118	0.004
574-244	4.256	0.03	0.118	0.004
574-245	4.381	0.03	0.118	0.004
574-246	4.506	0.03	0.118	0.004

Back-Up Rings Style 574 Buna-N

Part Number	I.D.	Tol. +/-	W	Tol. +/-
574-247	4.631	0.03	0.118	0.004
574-248	4.768	0.03	0.118	0.004
574-249	4.893	0.035	0.118	0.004
574-250	5.018	0.035	0.118	0.004
574-251	5.143	0.035	0.118	0.004
574-252	5.268	0.035	0.118	0.004
574-253	5.393	0.035	0.118	0.004
574-254	5.518	0.035	0.118	0.004
574-255	5.643	0.035	0.118	0.004
574-256	5.768	0.035	0.118	0.004
574-257	5.893	0.035	0.118	0.004
574-258	6.018	0.035	0.118	0.004
574-259	6.268	0.04	0.118	0.004
574-260	6.518	0.04	0.118	0.004
574-261	6.768	0.04	0.118	0.004
574-262	7.018	0.04	0.118	0.004
574-263	7.268	0.045	0.118	0.004
574-264	7.518	0.045	0.118	0.004
574-265	7.768	0.045	0.118	0.004
574-266	8.018	0.045	0.118	0.004
574-267	8.268	0.05	0.118	0.004
574-268	8.518	0.05	0.118	0.004
574-269	8.768	0.05	0.118	0.004
574-270	9.018	0.05	0.118	0.004
574-271	9.268	0.055	0.118	0.004
574-272	9.518	0.055	0.118	0.004
574-273	9.768	0.055	0.118	0.004
574-274	10.018	0.055	0.118	0.004
574-275	10.518	0.055	0.118	0.004
574-276	11.018	0.065	0.118	0.004
574-277	11.518	0.065	0.118	0.004
574-278	12.018	0.065	0.118	0.004
574-279	13.018	0.065	0.118	0.004
574-280	14.018	0.065	0.118	0.004

Back-Up Rings Style 574 Buna-N

Part Number	I.D.	Tol. +/-	W	Tol. +/-
574-281	15.018	0.065	0.118	0.004
574-282	15.989	0.075	0.118	0.004
574-283	16.989	0.08	0.118	0.004
574-284	17.989	0.085	0.118	0.004
574-309	0.45	0.005	0.183	0.005
574-310	0.513	0.007	0.183	0.005
574-311	0.575	0.007	0.183	0.005
574-312	0.638	0.009	0.183	0.005
574-313	0.7	0.009	0.183	0.005
574-314	0.763	0.01	0.183	0.005
574-315	0.825	0.01	0.183	0.005
574-316	0.888	0.01	0.183	0.005
574-317	0.95	0.01	0.183	0.005
574-318	1.013	0.01	0.183	0.005
574-319	1.075	0.01	0.183	0.005
574-320	1.138	0.012	0.183	0.005
574-321	1.2	0.012	0.183	0.005
574-322	1.263	0.012	0.183	0.005
574-323	1.316	0.012	0.183	0.005
574-324	1.388	0.012	0.183	0.005
574-325	1.513	0.015	0.183	0.005
574-326	1.638	0.015	0.183	0.005
574-327	1.763	0.015	0.183	0.005
574-328	1.888	0.015	0.183	0.005
574-329	2.013	0.018	0.183	0.005
574-330	2.138	0.018	0.183	0.005
574-331	2.268	0.018	0.183	0.005
574-332	2.393	0.018	0.183	0.005
574-333	2.518	0.02	0.183	0.005
574-334	2.643	0.02	0.183	0.005
574-335	2.768	0.02	0.183	0.005
574-336	2.893	0.02	0.183	0.005
574-337	3.018	0.024	0.183	0.005
574-338	3.143	0.024	0.183	0.005

Back-Up Rings Style 574 Buna-N

Part Number	I.D.	Tol. +/-	W	Tol. +/-
574-339	3.273	0.024	0.183	0.005
574-340	3.398	0.024	0.183	0.005
574-341	3.523	0.024	0.183	0.005
574-342	3.648	0.028	0.183	0.005
574-343	3.773	0.028	0.183	0.005
574-344	3.898	0.028	0.183	0.005
574-345	4.028	0.028	0.183	0.005
574-346	4.153	0.028	0.183	0.005
574-347	4.278	0.03	0.183	0.005
574-348	4.403	0.03	0.183	0.005
574-349	4.528	0.03	0.183	0.005
574-350	4.653	0.03	0.183	0.005
574-351	4.778	0.03	0.183	0.005
574-352	4.903	0.03	0.183	0.005
574-353	5.028	0.037	0.183	0.005
574-354	5.153	0.037	0.183	0.005
574-355	5.278	0.037	0.183	0.005
574-356	5.403	0.037	0.183	0.005
574-357	5.528	0.037	0.183	0.005
574-358	5.653	0.037	0.183	0.005
574-359	5.778	0.037	0.183	0.005
574-360	5.903	0.037	0.183	0.005
574-361	6.028	0.037	0.183	0.005
574-362	6.278	0.04	0.183	0.005
574-363	6.528	0.04	0.183	0.005
574-364	6.778	0.04	0.183	0.005
574-365	7.028	0.04	0.183	0.005
574-366	7.278	0.045	0.183	0.005
574-367	7.528	0.045	0.183	0.005
574-368	7.778	0.045	0.183	0.005
574-369	8.028	0.045	0.183	0.005
574-370	8.278	0.05	0.183	0.005
574-371	8.528	0.05	0.183	0.005
574-372	8.778	0.05	0.183	0.005

Back-Up Rings Style 574 Buna-N

Part Number	I.D.	Tol. +/-	W	Tol. +/-
574-373	9.028	0.05	0.183	0.005
574-374	9.278	0.055	0.183	0.005
574-375	9.528	0.055	0.183	0.005
574-376	9.778	0.055	0.183	0.005
574-377	10.028	0.055	0.183	0.005
574-378	10.528	0.06	0.183	0.005
574-379	11.028	0.06	0.183	0.005
574-380	11.528	0.065	0.183	0.005
574-381	12.028	0.065	0.183	0.005
574-382	13.028	0.065	0.183	0.005
574-383	14.028	0.07	0.183	0.005
574-384	15.028	0.07	0.183	0.005
574-385	16.008	0.075	0.183	0.005
574-386	17.008	0.08	0.183	0.005
574-387	18.008	0.085	0.183	0.005
574-388	19.006	0.09	0.183	0.005
574-389	20.006	0.095	0.183	0.005
574-390	21.006	0.095	0.183	0.005
574-391	22.006	0.1	0.183	0.005
574-392	22.993	0.105	0.183	0.005
574-393	23.993	0.11	0.183	0.005
574-394	24.993	0.115	0.183	0.005
574-395	25.993	0.12	0.183	0.005
574-425	4.551	0.033	0.236	0.006
574-426	4.676	0.033	0.236	0.006
574-427	4.801	0.033	0.236	0.006
574-428	4.926	0.033	0.236	0.006
574-429	5.051	0.037	0.236	0.006
574-430	5.176	0.037	0.236	0.006
574-431	5.301	0.037	0.236	0.006
574-432	5.426	0.037	0.236	0.006
574-433	5.551	0.037	0.236	0.006
574-434	5.676	0.037	0.236	0.006
574-435	5.801	0.037	0.236	0.006

Back-Up Rings Style 574 Buna-N

Part Number	I.D.	Tol. +/-	W	Tol. +/-
574-436	5.926	0.037	0.236	0.006
574-437	6.051	0.037	0.236	0.006
574-438	6.274	0.04	0.236	0.006
574-439	6.525	0.04	0.236	0.006
574-440	6.774	0.04	0.236	0.006
574-441	7.024	0.04	0.236	0.006
574-442	7.274	0.045	0.236	0.006
574-443	7.524	0.045	0.236	0.006
574-444	7.774	0.045	0.236	0.006
574-445	8.024	0.045	0.236	0.006
574-446	8.524	0.055	0.236	0.006
574-447	9.024	0.055	0.236	0.006
574-448	9.524	0.055	0.236	0.006
574-449	10.024	0.055	0.236	0.006
574-450	10.524	0.06	0.236	0.006
574-451	11.024	0.06	0.236	0.006
574-452	11.524	0.06	0.236	0.006
574-453	12.024	0.06	0.236	0.006
574-454	12.524	0.06	0.236	0.006
574-455	13.024	0.06	0.236	0.006
574-456	13.524	0.07	0.236	0.006

Back-Up Rings Style 574 Buna-N

Part Number	I.D.	Tol. +/-	W	Tol. +/-
574-457	14.024	0.07	0.236	0.006
574-458	14.524	0.07	0.236	0.006
574-459	15.024	0.07	0.236	0.006
574-460	15.524	0.07	0.236	0.006
574-461	16.004	0.075	0.236	0.006
574-462	16.504	0.075	0.236	0.006
574-463	17.004	0.08	0.236	0.006
574-464	17.504	0.085	0.236	0.006
574-465	18.004	0.085	0.236	0.006
574-466	18.504	0.085	0.236	0.006
574-467	19.004	0.09	0.236	0.006
574-468	19.504	0.09	0.236	0.006
574-469	20.004	0.096	0.236	0.006
574-470	21.004	0.095	0.236	0.006
574-471	22.004	0.1	0.236	0.006
574-472	23.004	0.105	0.236	0.006
574-473	24.004	0.11	0.236	0.006
574-474	25.004	0.115	0.236	0.006
574-475	26.004	0.12	0.236	0.006
574-474	25.004	0.115	0.236	0.006
574-475	26.004	0.12	0.236	0.006



AVOIDING SPIRAL TWIST

To minimize breakaway friction, an O-Ring groove must be wide enough to allow rolling or twisting of the seal. In the long stroke of a reciprocating seal application, this twisting action can strain and eventually tear the rubber, causing a failure mode known as spiral twist.

To prevent spiral twist, the Quad-Ring® seal's four-lobed configuration is designed to withstand the distortion and extrusion often caused by high or pulsating pressure. To accommodate these forces, a Quad-Ring® seal uses a narrower groove than a comparable O-Ring seal.

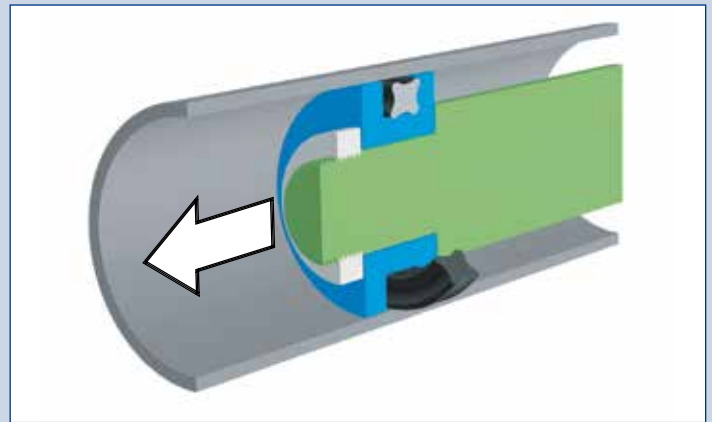
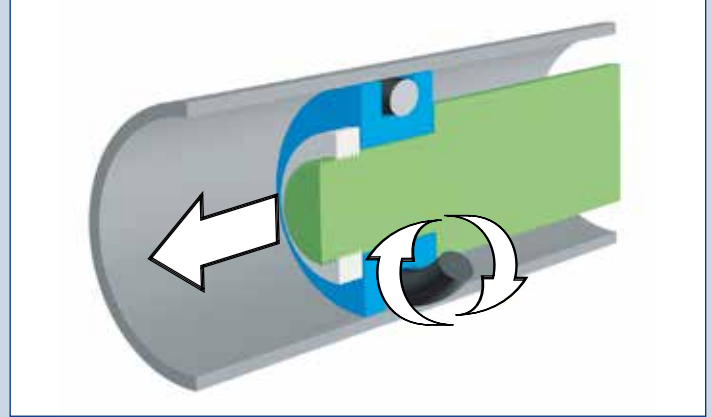
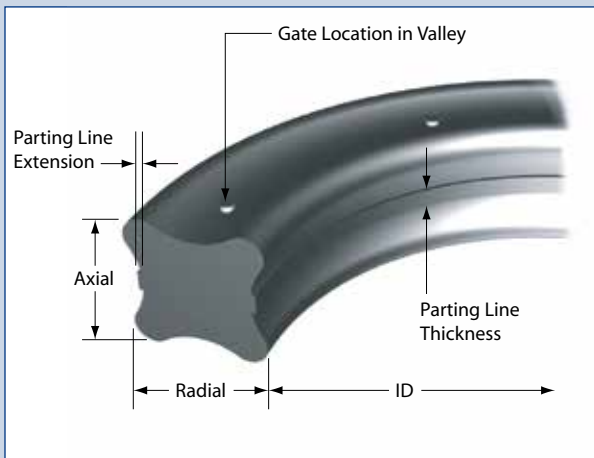

LONGER SEAL LIFE

Because less squeeze means less friction with the four-lobe design, seals last longer. This means equipment in which the Quad-Ring® seal is installed will operate longer and require less maintenance.

NO PARTING LINE ON SEALING SURFACE

Unlike O-Rings, where partitioning lines are on the sealing surface, Quad-Rings® seal's parting lines lie between the lobes, away from the sealing surface. This design eliminates the problems of leakage resulting from a parting line's irregular surface.

RING SIZE	CROSS-SECTION		DYNAMIC RECOMMENDED GLAND DEPTH "C"		STATIC RECOMMENDED GLAND DEPTH "C"		AXIAL GROOVE WIDTH "D"		GROOVE ECCENTRICITY (TIR)	
	(inches)	(mm)	(inches)	(mm)	(inches)	(mm)	+0.005/-0.000 (inches)	+0.005/-0.000 (mm)	(inches)	(mm)
Q4004-Q4050	.070 +/- .003	1.78 +/- 0.08	.061	1.55	.056	1.42	.080	2.03	.002	0.05
Q4102-Q4178	.103 +/- .003	2.62 +/- 0.08	.094	2.39	.089	2.26	.115	2.92	.002	0.05
Q4201-Q4284	.139 +/- .004	3.53 +/- 0.10	.128	3.25	.122	3.10	.155	3.94	.003	0.08
Q4309-Q4395	.210 +/- .005	5.33 +/- 0.13	.196	4.98	.188	4.78	.240	6.10	.004	0.10
Q4425-Q4475	.275 +/- .006	6.99 +/- 0.15	.256	6.50	.244	6.20	.310	7.87	.005	0.13

GROOVE DESIGN: QUAD-RING SEALS FOR STATIC AND NON-ROTARY DYNAMIC APPLICATIONS

1. Cross-section

Select a Quad-Ring cross section size from the available standard sizes.

2. Clearance

Determine the maximum clearance present in your application. For a radial seal, subtract the minimum rod (shaft) diameter. For a face seal, subtract the distance between the sealing surface and the mating surface.

3. Check the Clearance

Determine if the clearance is acceptable for the application pressures and the material hardness being used. Standard-line products are made from materials having a hardness of 70 Shore A. If the clearance is unacceptable, component tolerance will have to be tightened, a harder material will have to be special ordered, or a back-up ring will have to be used.

4. Calculate Quad-Ring Groove Dimensions

Using the table above, determine the maximum recommended gland depth for your application. Then, calculate the Quad-Ring groove diameter as follows:

a. For a rod (shaft) seal:

$$\text{Quad-Ring Groove Diameter} = \text{Min Shaft Diameter} + (2 \times \text{Recommended Gland Depth})$$

b. For a bore (piston) seal:

$$\text{Quad-Ring Groove Diameter} = \text{Max Bore Diameter} - (2 \times \text{Recommended Gland Depth})$$

c. For a face seal:

$$\text{Quad-Ring Groove Depth} = \text{Recommended Gland Depth} - \text{Application Clearance}$$

With a face seal, if the two surfaces to be sealed are in direct contact (such as with a cover), the seal groove depth is simply the Recommended Gland Depth.

5. Groove Width

Refer to the table above to determine the groove width for the Quad-Ring cross-section size you have selected. If you are using a back-up ring in your application, increase the groove width by the maximum thickness of the back-up ring.

6. Percent Gland Fill

If the gland fill exceeds 100%, the groove will have to be redesigned. A good "rule-of-thumb" is to not exceed about 90% gland fill.

7. Calculate the Seal Squeeze

The recommended gland values in the table above have been developed to create a proper range of squeeze for many applications involving oil, hydraulic fluid, or normal lubricants, providing component tolerances are sufficiently controlled. In applications involving high pressure, large component tolerances, the need for very low frictional forces, or other types of fluids, the seal and groove design should be verified through an acceptable method, such as testing or engineering analysis.

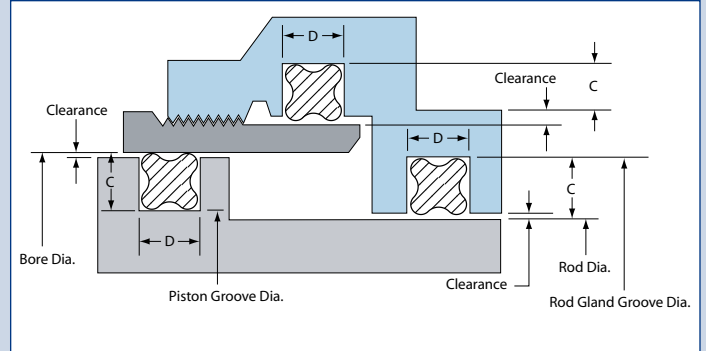

8. Select the Seal

If the bore or shaft size you are using is not listed, select the Quad-Ring with an inside diameter just smaller than the shaft you are using. If you are designing a face seal, select the Quad-Ring with an inside diameter which will position the Quad-Ring on the side of the groove opposite the pressure. Note: If the seal stretch is greater than 3% you may have to use the next size up.

9. Detail the Groove

Complete the groove design by specifying the proper radii and finish as indicated in the figure above.

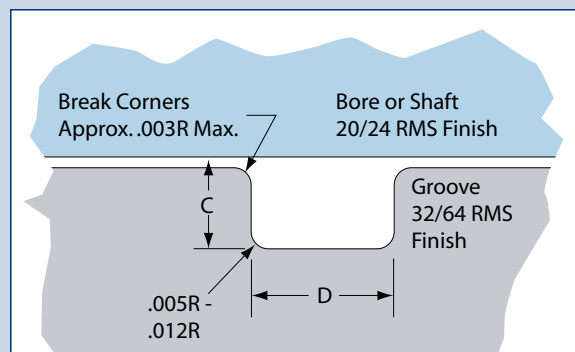

Daemar® Metallic O-Rings are designed to prevent leakage of gases or liquids under adverse sealing conditions. These static, metal-to-metal seals can withstand pressures from high vacuum to 100,000 psi (6,804 atm). They can endure continuous temperatures from - 425°F up to 1,800°F.

(-269°C to 982°C.), or intermittent temperatures up to 3,000°F. (1,650°C.). They resist radiation, chlorides, corrosives, and other hostile environments. They will not deteriorate with age, either in use or in storage.

Design, Materials, Coatings, Sizes

Daemar® Metallic O-Rings, designated MOR, are made of metal tubing (or solid rod) which is formed into circular or other shapes and the two ends welded together. The O-Ring metal is stainless steel or other alloys. The O-Ring can be electroplated with silver, copper, indium, nickel, gold, lead or other metals, or it can be coated with Teflon. The flow of the finish material improves the sealing, especially under high pressure and/or vacuum. Since tensile strength and resilience of the seal are determined in part by metal temper, Daemar® Components offers

a choice of heat treating to material specification or tempering to customer specifications.

Application Characteristics

The typical application places a Metallic O-Ring in axial compression between parallel faces, which are square to the fluid passage or vessel axis. The seal is usually located in an open or closed groove in one face. It can also be located in a retainer, which eliminates the need for machining a groove.

Upon compression to a predetermined fixed height, the seal tubing buckles slightly, resulting in two contact areas on the seal face and maximum contact stress between the seal and the mating faces. When the flange faces are closed, the O-Ring is under compression and tends to spring back against the flanges, thus exerting a positive sealing force. If the O-Ring is the self-energizing type, the pressure of the gas or liquid on the vented side energizes the seal and further increases the sealing force by pushing the seal against the flange face.

TYPES OF METALLIC O-RINGS

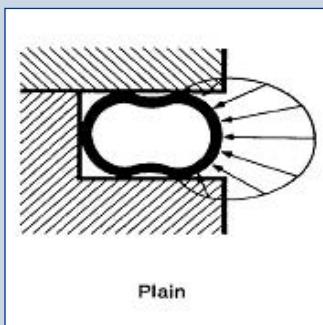

Plain

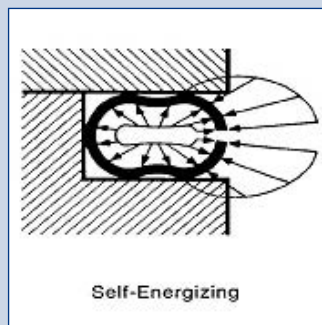

Self-Energizing

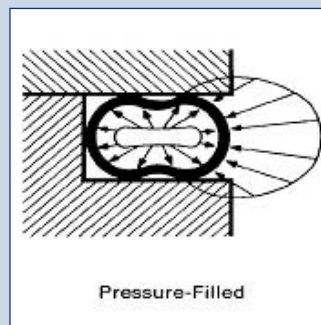

Pressure-Filled

Plain

(Not Self-Energizing or Pressure-Filled)

Made of metal tubing (or solid rod) in most metals. This type is the most economical O-Ring. It is designed for low to moderate pressure and vacuum conditions.

Self-Energizing

The inner periphery of the O-Ring is vented by small holes or a slot. The pressure inside the ring becomes the same as in

the system. Increasing the internal pressure increases sealing effectiveness.

Pressure-Filled

Pressure-filled O-Rings are designed for a temperature range of 800°F to 2,000°F (425°C to 1093°C). They cannot tolerate pressures as high as the self-energizing type. The ring is filled with an inert gas at about 600 psi (41 atm). At elevated temperatures, gas pressure increases, offsetting loss of strength in tubing and increasing sealing stress.

CHARACTERISTIC CURVE

Note: Actual spring back and load will vary based on material, geometry and wall thickness. Please check characteristic chart for specific information.

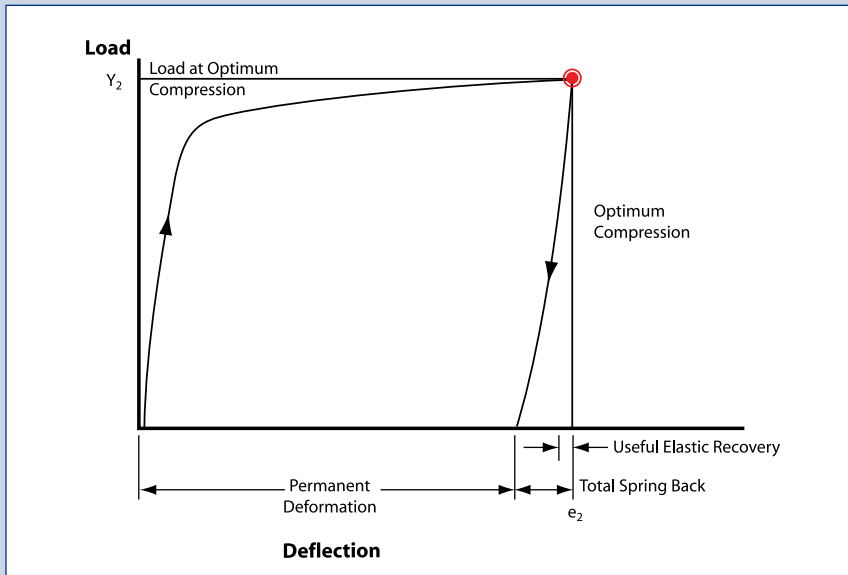

MATERIAL SELECTION

Material	Temperature	Heat Treatment
SS321	T < 700°F	NA
Alloy 600	T < 1,000°F	NA
Alloy X750	T < 1,100°F	NA
Alloy 718	T < 1,200°F	NA
Other	Contact a Daemar Technical Representative	

PLATING/COATING SELECTION

Plating/Coating	Standard Thickness	Temperature	Groove Finish*
PTFE	.001/.003	T < 500°F	16 –32 RMS
Silver	.001/.002	T < 800°F	16 –63 RMS
Silver w/ Gold Strike	.001/.002	T < 1,200°F	16 –63 RMS
Nickel	.001/.002	T < 1,600°F	16 –32 RMS
None	-	-	<16 RMS
Other	Contact a Daemar Technical Representative		

Dimensions in inches

*Groove finish must follow seal circumference (lathe turned finish).

Contact Daemar technical sales representative for non-standard thicknesses.

CHARACTERISTIC VALUES

Free Height	Compression e^2	Seal Diameter Range	Material Thickness	Thin (T) Medium (M) Heavy (H)	Characteristic Values at 70°F		
					SS321	Alloy 600	Alloy X-750
					Seating Load (PCI) Y2	Seating Load (PCI) Y2	Seating Load (PCI) Y2
0.032	0.006	0.500 to 4,000+	0.006	T	457	503	594
			0.010	M	1028	1131	1336
			-	H	-	-	-
0.063	0.012	2,000 to 40,000+	0.010	T	571	628	742
			0.012	M	799	879	1039
			0.014	H	1256	1382	1633
0.094	0.020	5,000 to 50,000+	0.010	T	343	377	446
			0.012	M	514	565	668
			0.018	H	1313	1444	1707
0.125	0.026	3,000 to 50,000+	0.010	T	343	377	446
			0.020	M	1142	1256	1485
			0.025	H	2056	2262	2673
0.156	0.031	5,000 to 50,000+	-	T	-	-	-
			0.020	M	857	943	1114
			0.025	H	1428	1571	1856
0.188	0.039	4,000 to 50,000+	-	T	-	-	-
			0.020	M	657	723	854
			0.032	H	2113	2324	2747
0.250	0.051	5,000 to 50,000+	0.025	T	799	879	1039
			0.032	M	1370	1507	1781
			0.049	H	3026	3329	3934

Dimensions in inches

Notes:

- 1) PCI = pounds force per circumferential inch
- 2) Seating Load (Y2) is an approximation and may vary based on groove clearance, sea; diameter, tolerance and plating thickness. It does not allow for system pressure requirements and should be verified for each application and seal size.
- 3) The customer must verify that system bolts and flanges can generate the required seating load without warping or distortion.
- 4) The customer must test and verify that the seal design meets the customer designated performance requirements.

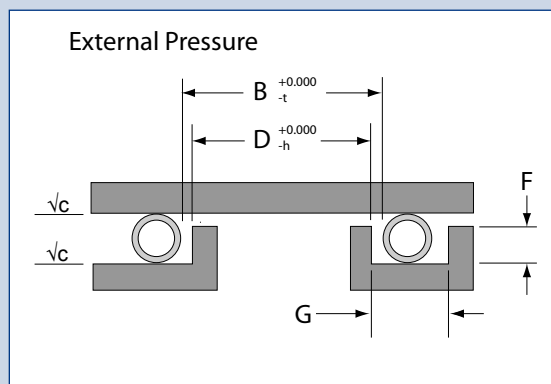
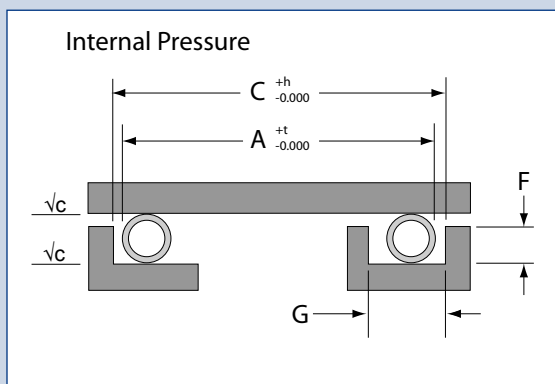

SEAL AND GROOVE SIZING CALCULATIONS

The equations below can be used for basic groove calculations. Applications that have significant thermal expansion may require additional clearance. Please contact Daemar for design assistance.

Determining Seal Diameter:

Internal

$$A = C - X - 2P_{max}$$

External

$$B = D + X + 2P_{max}$$

Determining Groove Diameter:

Internal

$$C = A + X + 2P_{max}$$

External

$$D = B - X - 2P_{max}$$

Tolerancing: See Chart

Where:

A = Seal Outer Diameter

B = Seal Inner Diameter

C = Groove Outer Diameter

D = Groove Inner Diameter

P_{max} = Maximum Plating or Coating Thickness

X = Diametrical Clearance

Groove Finish √ c: See Plating/Coating Section

SEAL AND GROOVE DIMENSIONS

Seal			Groove			
Free Height	Seal Diameter Range	Seal Tolerance t	Diametrical Clearance x	Groove Tolerance h	Groove Depth F	Groove Width (Min.) G
0.032	0.500 to 4.000	0.005	0.006	0.004	0.026±0.001	0.055
0.063	0.500 to 10.000	0.005	0.006	0.004	0.051±0.001	0.090
0.094	1.000 to 20.000	0.005	0.008	0.004	0.073±0.002	0.125
0.125	2.000 to 40.000	0.005	0.008	0.004	0.099±0.002	0.160
0.156	3.000 to 50.000+	0.005	0.014	0.006	0.125±0.002	0.200
0.188	4.000 to 50.000+	0.005	0.014	0.006	0.149±0.002	0.250
0.250	5.000 to 50.000+	0.008	0.019	0.008	0.199±0.002	0.350

Dimensions in inches

PART NUMBERING SYSTEM

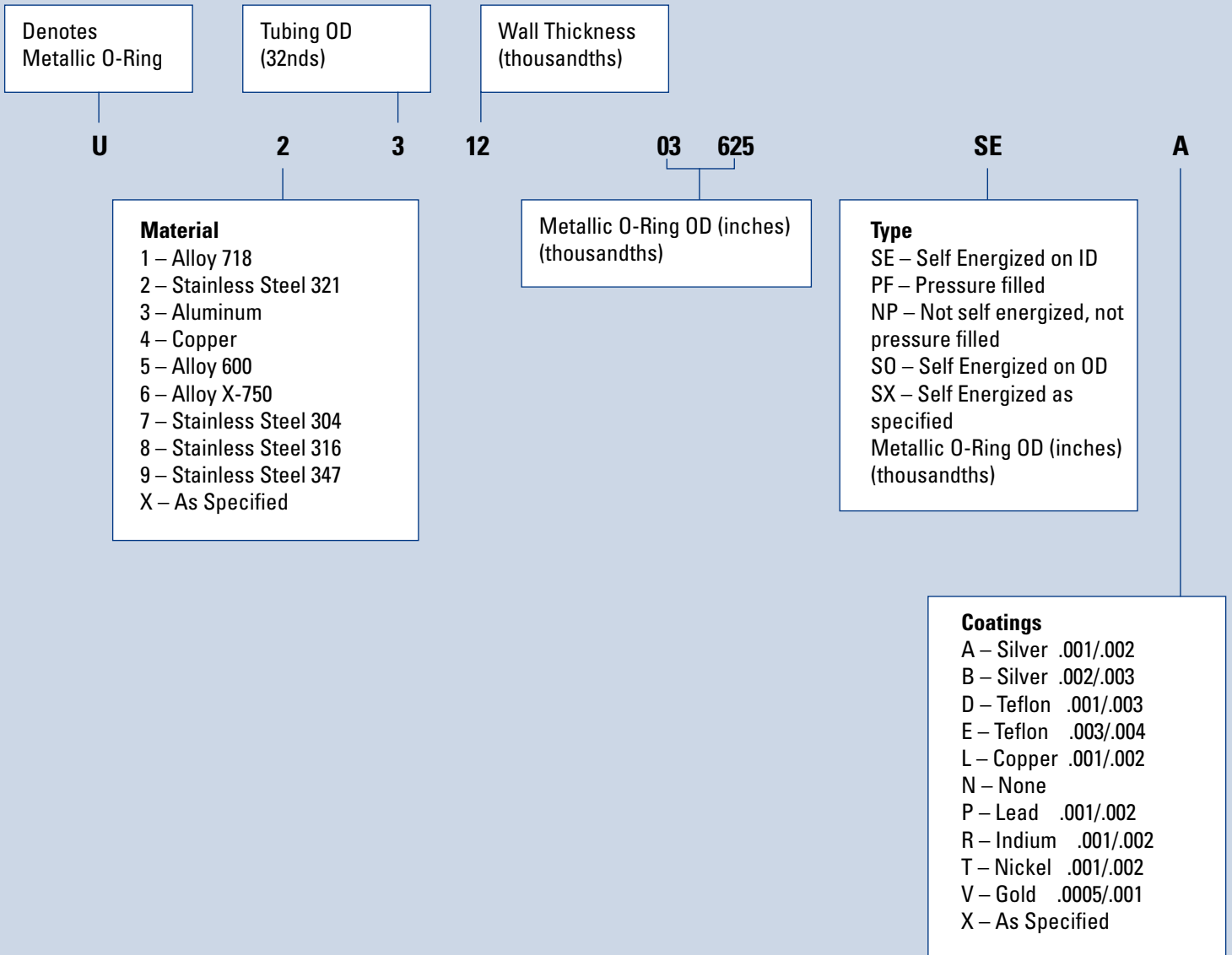

INCH O-RING KITS

ORK-2			Inch Sizes			382 Rings		
NO.	W	I.D.	O.D.	NO.	W	I.D.	O.D.	
006	1/16	1/8	1/4	211	1/8	13/16	1-1/16	
007	1/16	5/32	9/32	212	1/8	7/8	1-1/8	
008	1/16	3/16	5/16	213	1/8	15/16	1-3/16	
009	1/16	7/32	11/32	214	1/8	1	1-1/4	
010	1/16	1/4	3/8	215	1/8	1-1/16	1-5/16	
011	1/16	5/16	7/16	216	1/8	1-1/8	1-3/8	
012	1/16	3/8	1/2	217	1/8	1-3/16	1-7/16	
110	3/32	3/8	9/16	218	1/8	1-1/4	1-1/2	
111	3/32	7/16	5/8	219	1/8	1-5/16	1-9/16	
112	3/32	1/2	11/16	220	1/8	1-3/8	1-5/8	
113	3/32	9/16	3/4	221	1/8	1-7/16	1-11/16	
114	3/32	5/8	13/16	222	1/8	1-1/2	1-3/4	
115	3/32	11/16	7/8	325	3/16	1-1/2	1-7/8	
116	3/32	3/4	15/16	326	3/16	1-5/8	2	
210	1/8	3/4	1	327	3/16	1-3/4	2-1/8	

ORK-1-V			Inch Sizes			382 Rings		
NO.	W	I.D.	O.D.	NO.	W	I.D.	O.D.	
006	1/16	1/8	1/4	211	1/8	13/16	1-1/16	
007	1/16	5/32	9/32	212	1/8	7/8	1-1/8	
008	1/16	3/16	5/16	213	1/8	15/16	1-3/16	
009	1/16	7/32	11/32	214	1/8	1	1-1/4	
010	1/16	1/4	3/8	215	1/8	1-1/16	1-5/16	
011	1/16	5/16	7/16	216	1/8	1-1/8	1-3/8	
012	1/16	3/8	1/2	217	1/8	1-3/16	1-7/16	
110	3/32	3/8	9/16	218	1/8	1-1/4	1-1/2	
111	3/32	7/16	5/8	219	1/8	1-5/16	1-9/16	
112	3/32	1/2	11/16	220	1/8	1-3/8	1-5/8	
113	3/32	9/16	3/4	221	1/8	1-7/16	1-11/16	
114	3/32	5/8	13/16	222	1/8	1-1/2	1-3/4	
115	3/32	11/16	7/8	325	3/16	1-1/2	1-7/8	
116	3/32	3/4	15/16	326	3/16	1-5/8	2	
210	1/8	3/4	1	327	3/16	1-3/4	2-1/8	

METRIC O-RING KITS

MORK-1			Metric Sizes			401 Rings		
SIZE	QTY.	SIZE	QTY.	SIZE	QTY.	SIZE	QTY.	
3 x 1	38	14 x 2	17	20 x 4	9	45 x 4	9	
4 x 1	17	17 x 2	17	22 x 4	9	47 x 4	9	
5 x 2	9	20 x 2	17	24 x 4	9	50 x 4	9	
6 x 2	17	10 x 3	12	25 x 4	9	16 x 5	7	
8 x 2	17	12 x 3	12	30 x 4	9	25 x 5	14	
10 x 2	17	16 x 3	12	34 x 6	9	30 x 5	7	
11 x 2	17	18 x 3	12	36 x 4	9	32 x 5	7	
12 x 2	17	22 x 3	12	40 x 4	9	35 x 5	7	



SPECIALTY KITS

QUAD RING KIT				226 Rings			
SIZE	QTY.	SIZE	QTY.	SIZE	QTY.	SIZE	QTY.
4005	10	4014	6	4114	6	4211	5
4006	10	4015	6	4115	6	4212	5
4007	10	4016	6	4116	6	4213	5
4008	10	4017	5	4117	4	4214	5
4009	10	4018	5	4118	4	4215	5
4010	10	4110	6	4119	4	4216	5
4011	10	4111	6	4120	4	4217	5
4012	10	4112	6	4121	4	4218	5
4013	6	4113	6	4210	5	4219	5

SPLICING KITS (METRIC & INCH)

SPL-KT-BUNA	
SIZE	LENGTH
0.070"	1 M
0.103"	1 M
0.139"	1 M
0.210"	1 M
0.275"	1 M

SPL-KT-MET	
SIZE	LENGTH
1.50mm	1 M
2.00mm	1 M
2.50mm	1 M
3.00mm	1 M
3.50mm	1 M
4.00mm	1 M
5.00mm	1 M
5.70mm	1 M
8.40mm	1 M

BOSS KIT						212 Rings					
SIZE	QTY.	SIZE	QTY.	SIZE	QTY.	SIZE	QTY.	SIZE	QTY.	SIZE	QTY.
901	10	905	12	909	12	913	10	920	10		
902	10	906	12	910	12	914	10	924	10		
903	10	907	12	911	10	916	10	928	10		
904	10	908	12	912	10	918	10	932	10		

STORAGE & SHELF LIFE OF ELASTOMER COMPOUNDS

Storage life varies with resistance of each synthetic elastomer to normal storage conditions. Use this reference chart as a guideline as to how long an O-ring can be stored.

To more realistically meet the needs of the sealing industry in 1998 SAE (Society of Aerospace Engineers) developed ARP 5316 to provide a basis for establishing elastomer shelf life. The table below summarizes the recommended shelf life for the most common elastomers:

SHELF LIFE	ELASTOMER GROUPS
5 Years:	Polyurethane
15 Years:	Nitrile, Neoprene, SBR, HNBR, Polyacrylate
Unlimited:	Ethylene Propylene, Fluorocarbon, Perfluorinated Elastomer, Butyl, Silicone, Tetrafluoroethylene Propylene (Aflas®), Fluorosilicone.

This table and the complete ARP 5316 standard take into account the most recent technological advancements in polymer formulation and thus more accurately reflect the shelf life that should be expected from elastomeric o-rings.

Where non-age sensitive elastomers mentioned in 15 year and unlimited categories are involved, considerable storage life without detectable damage is common even under adverse conditions. For materials mentioned in the 5 year category, which are subject to deterioration, the following conditions are suggested for maximum life:

1. Ambient temperature not exceeding 120°F (49°C)
2. Exclusion of air (oxygen)
3. Exclusion of contamination
4. Exclusion of light (particularly sunlight)
5. Exclusion of ozone generating electrical devices
6. Exclusion of radiation

Generally, polyethylene bags stored in larger cardboard containers or polyethylene lined craft paper bags insure optimal storage life. However, in normal warehousing conditions, life of even the relatively age-sensitive elastomers is considerable.

Like any device subject to judgment in design, or to human error during installation, O-ring seals are liable to failure. The following brief summary of O-ring failure patterns is intended to give the designer/engineer a brief overview of the more common types of failure and a listing of recommended corrective actions. While there are a number of different types and causes to seal failure, we intend here to cover only the types encountered most frequently.

WHY AN O-RING FAILS

The failure of an O-ring in service can usually be attributed to a combination of causes. Most often, with the absence of one of the conditions existing at the time of failure, the O-ring would have continued performing. It is important to maximize sealing life and reliability by reducing the probability of seal failure at the onset by the use of good design practices, proper compound selection, pre-production testing, and continued education and training of assembly personnel.

EXTRUSION AND NIBBLING

Extrusion and nibbling of the O-ring is a primary cause of seal failure in dynamic applications such as Hydraulic Rod and Piston seals. This form of failure may also be found from time to time in static applications subject to high pressure pulsing which causes the clearance gap of the mating flanges to open and close, trapping the O-ring between the mating surfaces.

Failure Analysis

In general, EXTRUSION and NIBBLING are caused by one or more of the following conditions:

1. Excessive clearances.
2. High pressure (in excess of system design or high pressure excursions).
3. O-ring material too soft.
4. Degradation (swelling, softening, shrinking, cracking, etc.) of O-ring material by system fluid.
5. Irregular clearance gaps caused by eccentricity.
6. Increase in clearance gaps due to excessive system pressure.
7. Improper machining of O-ring gland (sharp edges).
8. Improper size (too large) O-ring installed causing excessive filling of groove.

Prevention/Correction

Suggested solutions to the causes of Extrusion and Nibbling listed above are:

1. Decrease clearance by reducing machining tolerances.
2. Use back-up devices.
3. Check O-ring material compatibility with system fluid.
4. Increase rigidity of metal components.
5. Replace current O-ring with a harder O-ring.
6. Break sharp edges of gland to a minimum radius 0.002 inches.
7. Insure installation of proper size O-rings.

Identification Of Extrusion Failure

A typical example of O-ring extrusion is when edges of the ring on the low pressure or downstream side of the gland exhibit a "chewed" or "chipped" appearance.

In an O-ring that has failed due to nibbling, it may have the appearance that many small pieces have been removed from the low pressure side. In some forms of extrusion, more than 50% of the O-ring may be destroyed before catastrophic leakage is observed.

COMPRESSION SET

Probably the most common cause of O-ring failure is compression set. An effective O-ring seal requires a continuous “seal line”

between the sealed surfaces. The establishment of this “seal line”

is a function of gland design and seal cross-section which determines the correct amount of squeeze (compression) on the O-ring to maintain seal integrity without excessive deformation of the seal element. There are a number of factors that can contribute to compression set failure of an O-ring seal. They are listed below.

Failure Analysis

In general, COMPRESSION SET is caused by one or more of the following conditions:

1. Selection of O-ring material with inherently poor compression set properties.
2. Improper gland design.
3. Excessive temperature developed causing the O-ring to harden and lose its elastic properties.
4. Volume swell of the O-ring due to system fluid.
5. Excessive squeeze due to over tightening of adjustable glands.
6. Incomplete curing (vulcanization) of O-ring material during production.
7. Introduction of fluid incompatible with O-ring material.

Prevention/correction

Suggested solutions to the causes of compression set are:

1. Use “LOW-SET” O-ring material whenever possible.
2. Select O-ring material compatible with intended service conditions.
3. Reduce system operating temperature.
4. Check frictional heat build-up at seal interface and reduce if excessive.
5. Inspect incoming O-ring shipments for correct physical properties.

IDENTIFICATION OF COMPRESSION SET FAILURE

A typical example of classic O-ring compression set in simplistic terms: the O-ring ceases to be “O” shaped and is permanently deformed into a flat sided oval, the flat sides of which were the original seal interface and under compression before failure.

SPIRAL FAILURE

Spiral failure of an O-ring is often found on long stroke hydraulic piston seals and to a lesser degree on rod seals. This type of O-ring failure is caused when the seal becomes “hung-up” at one point on its diameter (against the cylinder wall) and slides and rolls at the same time. The resultant twisting of the O-ring as the sealed device is cycled finally causes the seal to develop a series of deep spiral cuts (usually at a 45° angle) on the surface of the seal.

Failure Analysis

As stated above, spiral failure is generally caused by an O-ring both sliding and rolling at the same time. Conditions which may cause this to occur are:

1. Eccentric components.
2. Wide clearance combined with side loads.
3. Uneven surface finishes.
4. Inadequate or improper lubrication.
5. O-ring too soft.
6. Stroke speed (usually too slow).
7. Improper installation (O-ring pinched or rolled).

Prevention/correction

Suggested solutions to the causes of spiral failure are as follows:

1. Improve surface finish of sealed assembly at dynamic interface (Cylinder Bore, Piston Rod).
2. Check for out-of-round components (Cylinder Bores especially).
3. Provide proper lubrication.
4. Replace with a harder O-ring.
5. Consider use of alternate seal shapes

IDENTIFICATION OF SPIRAL FAILURE

You will see the typical cuts that gave this type of O-ring failure its name.

EXPLOSIVE DECOMPRESSION

With the advent of the space age we are seeing this type of O-ring failure with increasing frequency. It might be termed O-ring embolism, in that after a period of service under high pressure gas, when the pressure is reduced too rapidly, the gas trapped within the internal structure of the O-ring expands rapidly, causing small ruptures or pitting on the O-ring surface.

Failure Analysis

Explosive decompression, or gas expansion rupture is caused by high pressure gas trapped within the internal structure of the elastomeric seal element. Rapid decrease in system pressure causes the trapped gas to expand to match the external pressure and this expansion causes blisters and ruptures on the seal surface. If the volume of trapped gas is small, the blisters may recede as the pressure is equalized with little effect on seal integrity. Excessive trapped gas may cause total destruction of the seal.

Prevention/correction

Suggested solutions to explosive decompression are:

1. Increase decompression time to allow trapped gas to work out of seal material.
2. Choose a seal material with good resistance to explosive decompression.
3. If problem persists and pressures are very high consider use of metallic 'O' Ring or 'C' Ring.

IDENTIFICATION OF EXPLOSIVE DECOMPRESSION FAILURE

The seal subjected to explosive decompression will often exhibit small pits or blisters on its surface. In severe cases, examination of the internal structure of the O-ring will reveal other splits and fissures.

ABRASION

Another rather common type of O-ring failure is abrasion. This usually is found only in dynamic seals subject either to reciprocating, oscillating, or rotary motion. Possible causes of O-ring abrasion are listed below.

Failure Analysis

In general, abrasion of O-ring seals is caused by one or more of the following:

1. Improper finish of the surface in dynamic contact with the O-ring. This surface finish may be too rough, acting as an abrasive, or too smooth, causing inadequate lubrication due to inability of surface to hold lubricant.
2. Improper lubrication provided by system fluid.
3. Excessive temperatures.
4. Contamination of system fluid by abrasive particles.

Prevention And Correction

Suggested solutions to problems caused by abrasion are:

1. Use proper surface finish
2. Provide adequate lubrication by use of proper system fluid.
3. Consider use of internally lubricated O-rings to reduce friction and wear.
4. Check for contamination of fluid and eliminate source. Install filters if necessary.
5. Consider changing to an O-ring material with improved abrasion resistance.

IDENTIFICATION OF ABRASION FAILURE

The O-ring that has failed due to wear through abrasion usually exhibits a flat area on the side of the seal which was in contact with the dynamic surface. Frequently there will be wear lines on this flat surface parallel to the direction of motion. Abrasion failure may be differentiated from compression set failure in that with abrasion, only one side of the O-ring will be flat or worn while with compression set failure, both sides of the O-ring are equally deformed.

INSTALLATION DAMAGE

Many O-ring failures can be directly attributed to improper installation. In spite of its simple appearance, the O-ring is a precision device requiring care during installation. Some of the more frequent causes of O-ring failure due to careless handling are listed below.

Failure Analysis

Damage to an O-ring during installation can occur when:

1. There are sharp corners on mating metal components such as the O-ring gland or threads over which the O-ring must pass during assembly.
2. Insufficient lead-in chamfer.
3. Blind grooves in multi-port valves.
4. Oversize O-ring on piston seal application.
5. Under size O-ring on rod application.
6. O-ring twisted/pinched during installation.
7. O-ring not properly lubricated before installation.
8. O-ring dirty upon installation.
9. O-ring gland and/or other surfaces over which O-ring must pass during assembly contaminated with metal particles.
10. General carelessness.

Prevention And Correction

Probably the best way to prevent damage to O-rings during installation is the use of good common sense. There are some specific solutions which are listed below:

1. Break all sharp edges on metal components.
2. Provide a 20 degree lead-in chamfer.
3. Check all components for cleanliness before installation.
4. Tape all threads over which the O-ring will pass.
5. Use an O-ring lubricant
6. Double check O-ring to insure correct size and material.
7. Be CAREFUL.

IDENTIFICATION OF INSTALLATION FAILURE

It is difficult to properly illustrate the many possible results of installation failure. One of the more common failure modes is the "Skiving" of the O-ring surface due to cutting by metal components. Those cuts are usually very clean as if made with a very sharp knife. Another indication of bad installation will be small cuts or notches on the O-ring. In almost all cases, the damage will appear on the surface of the O-ring away from the bottom of the O-ring groove.

OTHER CAUSES OF O-RING FAILURE

Although not illustrated here, there are several other possible causes of O-ring failure. They are:

1. Weather and ozone degradation.
2. Heat aging and oxidation.
3. Loss of plasticizer.

SLIDE

SEAL

PROTECT

RETAIN

ALIGN



Dryslide™



Oil Seals



Tapered Caps and Plugs



Rotor Clip®



Woodruff Keys

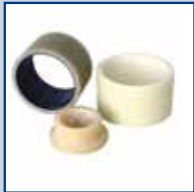

Fiber-Lube™



O-Ring Kits



Caps

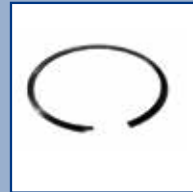

Spirolox®



Slotted Shim



Linear Motion



DMR Bearing Isolators



Plugs



Ring Masters®



Slotted Shim Kits



Powdered Metal



V-Rings



Finishing



Rotor Clamp®

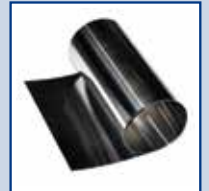

Shim Stock Rolls



Solid Metal



Shaft Repair Sleeves



Electronics



Retaining Ring Kits & Packs



Keystock



DMIR™

DAEMAR® INC.
861 CRANBERRY COURT
OAKVILLE, ON L6L 6J7
PH/905/847/6500
FX/905/847/6943
TF/800/387/7115
TFX/800/269/4571
sales@daemarinc.com

DAEMAR® INC.
548 MELOCHE
DORVAL, QC H9P 2T2
PH/514/636/3113
FX/514/633/1206
TF/800/361/6826
mtlsales@daemarinc.com

DAEMAR® INC.
4472-97TH STREET
EDMONTON, AB T6E 5R9
PH/780/435/8899
FX/780/435/9090
TF/800/214/9590
edmsales@daemarinc.com

DAEMAR® INC.
1635 Lakes Parkway, Suite F
Lawrenceville, GA 30043
PH/770/953/4710
FX/770/953/4711
TF/877/432/3627
atlanta@daemarinc.com

www.daemar.com

