

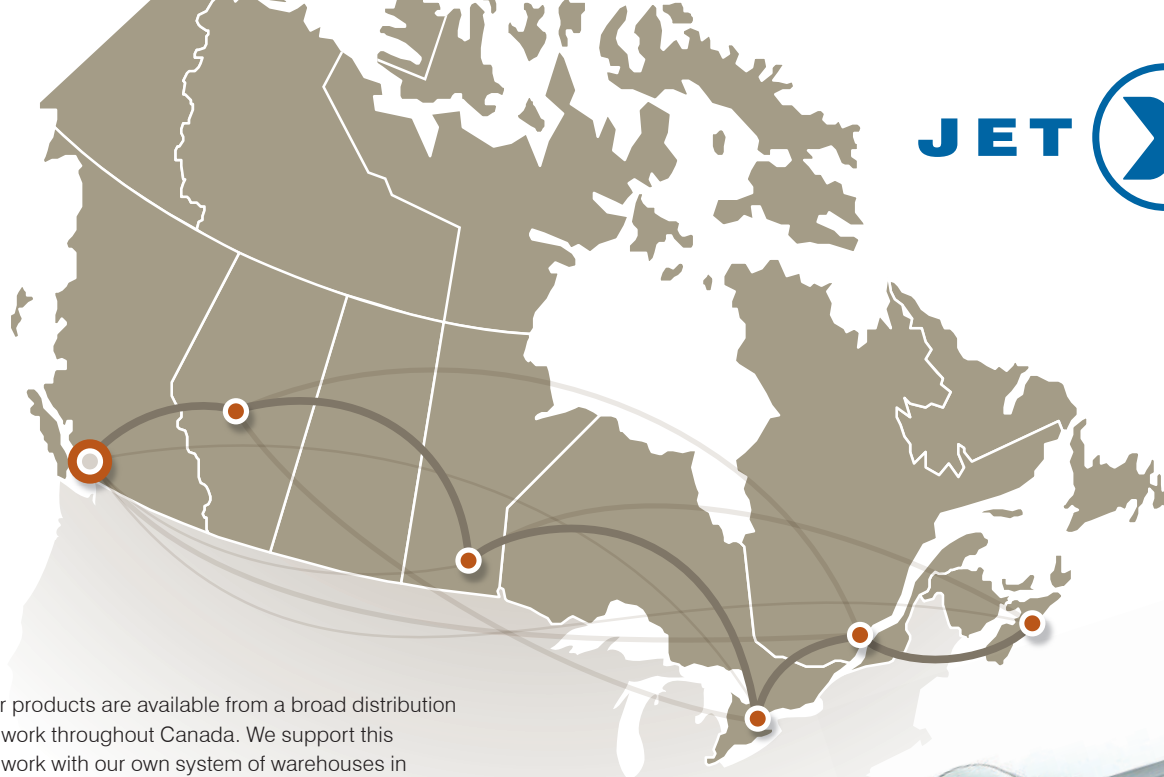

# HAND TOOLS

2014-15



Our products are available from a broad distribution network throughout Canada. We support this network with our own system of warehouses in Vancouver, Edmonton, Winnipeg, Toronto, Montréal and Halifax. This distribution network ensures fast deliveries and superior service to our customers.

Date of publication October, 2014  
Prod. No. **899907**



### **WESTERN CANADA & TERRITORIES (VANCOUVER CUSTOMER SERVICE CENTRE)**

Toll Free Tel.: 1-800-472-7685  
Toll Free Fax: 1-800-663-7742  
Sales Tel.: 604-523-7600  
Sales Fax: 604-523-7693

### **HEAD OFFICE (VANCOUVER)**

Tel.: 604-523-TOOL (8665)  
Fax: 604-526-JET1 (5381)



### **ONTARIO & QUEBEC (TORONTO CUSTOMER SERVICE CENTRE)**

Toll Free Tel.: 1-800-387-3879  
Toll Free Tel.: 1-800-363-2885 (French)  
Toll Free Fax: 1-800-267-3310  
Sales Tel.: 905-565-8661  
Sales Fax: 905-565-7266

### **ATLANTIC CANADA**

Toll Free Tel.: 1-800-472-7686  
Toll Free Fax: 1-877-468-3461  
Sales Tel.: 902-468-8324  
Sales Fax: 902-468-3461

# JET



Trades professionals everywhere understand the value of owning a JET quality hand tool. Whether your trade of choice is in the MRO, industrial or automotive after markets, JET has the quality and range of products to meet your most demanding needs. Each tool is carefully designed and manufactured using superior materials and workmanship in order to ensure the highest performance and productivity standards as well as long service life. When your livelihood depends on the tools that you use, JET is the brand of choice.

## Icon Legend

6 Point		Slotted Screwdriver		Warning Note	
12 Point		Slotted Screwdriver Square Shank		Made in Canada	
A2 Steel		Phillips Screwdriver		Made in USA	
S2 Steel		Square Screwdriver		Ball Bearing Slides	
Includes Case		Hex Screwdriver		New	
Includes Pouch		Torx® Screwdriver		JET Exclusive	
Chrome Molybdenum		Hex Key Head		Super Heavy Duty	
Chrome Nickel		Nut Driver			
Chrome Vanadium		TORX® Socket Head			
Use Eye Protection		External TORX®			



# Table of Contents

Table of Contents.....	4	New Products .....	8
Company Description .....	6		

## Tool Storage 10

Portable Tool Boxes.....	12	Shop Carts .....	28
Chests and Roller Cabinets.....	13-23	Workbenches .....	29
Job Site Tool Storage.....	21	Tool Organizers.....	30-31
Open Front Tool Chests.....	24-25		
Service Carts.....	26-27		

## Ratchet Wrenches 32

1/4", 3/8" & 1/2" Drive .....	34-38	3/4" & 1" Drive.....	39-40
-------------------------------	-------	----------------------	-------

## Chrome Sockets 41

<b>Socket Wrench Sets</b>		<i>TORX® Bits</i> .....	58
1/4" Drive.....	42-43	<b>External TORX®</b> .....	59
3/8" Drive.....	44-45	3/8" & 1/2" Drive External TORX® .....	60
1/2" Drive.....	46-47	<b>Open Stock</b>	
3/4" Drive.....	48	S.A.E. ....	60-61
1" Drive.....	49	Metric .....	62-63
<b>Sockets Sets</b>		S.A.E. Hex Bits.....	64
1/4" Drive.....	50	Metric Hex Bits.....	65
3/8" Drive.....	51-52	<i>TORX® Bits</i> .....	66
1/2" Drive.....	53-54	External TORX® .....	66
3/4" Drive.....	55	Socket Accessories.....	67-72
Hex Bits.....	56-57		

## Impact Sockets 73

<b>Sockets Sets</b>		1/2" Drive Hex Bit.....	84
3/8" Drive.....	74	3/4" Drive Hex Bit.....	85
1/2" Drive.....	75-77	3/8" & 1/2" Drive External TORX® .....	85
1/2" Drive Universal.....	78	Socket Accessories.....	86-87
Mag Wheel Sockets.....	78	<b>Open Stock</b>	
Torque Limiting Extensions .....	79	1" Drive Truck Tire.....	83
3/4" Drive.....	80-81	S.A.E. ....	88
1" Drive.....	81-82	Metric .....	89
1" Drive Truck Tire .....	83	Hex & TORX® Bits .....	90
1/2" Drive TORX® Bit .....	84		

## Wrenches 91

<b>Combination Wrenches</b>		<i>Ratcheting Wrenches</i> .....	102
Raised Panel.....	92-93	<i>Flare Nut Wrenches</i> .....	103
Multi-Fit.....	96	<i>Crowfoot Wrenches</i> .....	103
Fully Polished.....	94-95	<i>Adjustable Wrenches</i> .....	104-105
Stubby Polished.....	97	<i>Striking Wrenches</i> .....	106
<i>Ratcheting Wrench Sets</i> .....	98-100	<i>Structural Wrenches</i> .....	107
<i>Ratcheting Wrenches Open Stock</i> ....	101	<i>Adjustable Spanner Wrenches</i> .....	108

## Hex Key Wrenches 109

<b>Hex Key Wrenches</b>		<b>Open Stock</b>	
Folding Sets.....	110	<i>TORX® Key Wrenches</i> .....	114
Sets .....	111-113	<i>Hex Key Wrenches</i> .....	114

## Torque Wrenches 115

Torque Wrenches .....	116-118
Digital Torque Wrenches.....	119
Torque Multipliers.....	120

## Screwdrivers 121

<b>Jumbo Handle Series</b>		<b>Cushion Grip Screwdriver</b>	
Sets .....	122	Sets .....	128
Open Stock.....	123	Open Stock.....	129
<b>Torque Drive® Series</b>		Replacement Bits.....	351
Sets .....	124	Cushion Grip Multi-Bit Driver Sets..	130
Open Stock.....	125	15-in-1 Multi-Bit Driver Set.....	130
<b>Ergonomic Screwdrivers</b>		Ratcheting Drivers .....	131-133
Sets .....	126	Impact Driver.....	138
Open Stock.....	127	Precision Screwdriver Sets .....	138

## Screwdriver Bits 134

Insert Bits .....	134	Nutsetters .....	135
Power Bits.....	135		

## Nut Drivers 136

<b>Cushion Grip Nutdrivers</b>		<b>Jumbo Handle Series</b>	
Sets .....	136	Sets.....	137
Open stock.....	136	Open stock .....	137

## Pliers and Cutters 139

<b>Locking Pliers</b>		<b>Chrome Nickel Series</b>	
Sets .....	140	Sets .....	147
Open Stock.....	141-142	Open Stock .....	148-149
<b>Snap Ring Pliers</b>		Shears.....	150-151
Sets .....	143	Wire Strippers and Cutters .....	152
Open Stock.....	143	Rivet Tools.....	153
<b>Chrome Vanadium</b>		Rivet Guns .....	153
Sets .....	144		
Open Stock.....	145-146		

## Sheet Metal Tools 154

Aviation Snips .....	154-155
----------------------	---------

## VDE Tools 156

VDE Tool Kits.....	158-159	<b>VDE Nut Drivers</b>	
<b>VDE Screwdrivers</b>		Open Stock.....	161
Open Stock.....	160	<b>VDE Pliers and Cutters</b>	
		Open Stock.....	161

## Pipe Tools 162

Pipe Wrenches .....	164-165	Flaring Tools.....	169-170
Tube Cutters.....	166-167		
Pipe Cutter.....	167		
Tube Bender.....	167		
Deburring Tools .....	168		
Ratcheting PVC Pipe Cutter .....	168		

## Striking Tools 171

<b>Hammers</b>		Welding Hammer .....	179
Nailing Hammers .....	172-173	Axes and Mauls.....	179
Ball Pein Hammers .....	174-175	Soft Face Dead Blow Hammers	
Club Hammer.....	175	.....	180-181
Indestructible Handle		<b>Punch &amp; Chisel</b>	
Hammers .....	176-177	Sets .....	182-183
Sledge Hammers .....	178	Open Stock.....	184-186
Drilling Hammers.....	178	Stamps - Number/Letter.....	187
Rubber Hammers.....	179		

## Construction Tools 188

Bars POWERCLAW™ Series....	190-193	Staplers and Tackers .....	200-201
Bolt & Rod Cutters .....	194-195	Hacksaws Frames .....	202
Measuring Tools .....	196-199		

## Shop Equipment 203

<b>Clamping</b>		Parts Washers .....	214
C-Clamps .....	204-205	Creepers.....	215
L-Clamps .....	206-207	Roller Seats .....	216
Pipe Clamps.....	208	Anti-Fatigue Mats.....	217
Spring Hand Clamps.....	208		
Vises .....	209-211		
<b>Shop Equipment</b>			
Pallet Truck.....	212		
Scissor Lift Hand Cart .....	213		

## Metal Working Machinery 219

Bench Grinders .....	220	Metal Cutting	
Optional Accessories.....	220	Bandsaws .....	224-225
Drill Presses .....	221-223		

## Wood Working Machinery 226

Dust Collector.....	226
---------------------	-----

**Pullers 227**

Gear Pullers.....	228-229	Specialty Pullers.....	230
Bearing Separators.....	229		

**Lubrication / Fluid Transfer 231**

Grease Guns .....	232-234	Water, Chemical & Oil Pumps..	241-242
Grease Gun Hoses .....	234	Oil and Fuel Pumps .....	243-244
Grease Gun .....		Fuel and Gasoline Pumps.....	245-246
Accessories.....	235-236	Oil Drains.....	247-248
Grease Gun Couplers .....	239	Drum Handling.....	249
Grease Gun Holders.....	236		
Grease Fittings.....	237-238		
Grease Pumps .....	239		
Grease Pump Accessories.....	240		

**Specialty Automotive 250**

**Brake Service 178**

Brake Repair Tool .....	252	Flaring Tool Kits.....	254-255
Tube Benders and Cutters.....	253	Brake Repair Tools .....	255

**Hones 257**

**Bearing and Bushing Tools 258**

Bearing Packers .....	258	Truck Wheel Bearing Locknut	
Front Wheel Drive Axle Nut Tools ..	259	Sockets.....	259

**Suspension/Drive Train Repair 260**

Four Wheel Drive Spindle		Front End Service Tools.....	262-264
Locknut Tools.....	260-261		

**Cooling System 265**

Hose and Clamp Tools .....	265-266	Fan Clutch Wrenches .....	267
----------------------------	---------	---------------------------	-----

**Engine Service 268**

Compression and Pressure			
Testers .....	268-271		
Piston Ring Tools .....	272		
Tune-Up Tools.....	272-273		
Head and Valve Repair .....	272		
Valve Spring Compressors .....	272		
Valve Lapping Tools .....	273		

**Exhaust System 274**

Muffler Expanders.....	274	Pressure Testers .....	274
------------------------	-----	------------------------	-----

**Fuel/Injection System 275**

Fluid Line Tools.....	275-276	Pressure Testers .....	277
-----------------------	---------	------------------------	-----

**Sensor and Sender Units 278**

Open Stock Sockets.....	278		
-------------------------	-----	--	--

**Hand Tools 279**

Blow Guns.....	279	Hand Brushes .....	283
Pullers and Puller Kits .....	279-281	Scrapers .....	284
Bearing Separators.....	282	Seal Puller .....	284
Gear Pullers.....	282-283	Feeler Gauges .....	285

**Oil Filter/Drain Plug Tools 286**

Oil Filter Wrenches.....	286-287		
--------------------------	---------	--	--

**Fastener Tools 288**

Driver Bits and Sockets.....	288	Screwdrivers .....	289
Punches - Brass.....	288	Screw Extractors .....	289
Stud, Bolt and Nut Removal.....	288	Taps, Dies and Thread Repair .....	290
Pliers .....	288		

**Battery Service 291**

Post and Terminal Service.....	291	Testing Equipment .....	292
Battery Carrier .....	291		

**Electrical System 293**

Electrical Testers .....	293,296		
Spark Plug / Ignition Tools .....	294-295		

**Specialty Automotive 250**

**Pick-up Tools/Magnets/Mirrors 298**

Miscellaneous.....	298	Magnetic Pick-Up Tools.....	298
--------------------	-----	-----------------------------	-----

**Tire Service 299**

Tire Pressure Gauges .....	299-301	Air Inflator Gauges .....	302
Tire Valve Tools.....	301	Air Chucks.....	302
Pliers for Wheel Weights.....	301		

**Upholstery/Trim Panel Tools 303**

Upholstery Tools .....	303		
------------------------	-----	--	--

**Automotive Gauges 304**

Chrome Series Professional Duty..	304	HTA Series Replacement Parts.....	306
Chrome Series Heavy Duty		Tachometers .....	306
and Marine.....	305	Electrical Fuel Level Gauge Kit .....	306
Easy-Read Gauge Kits			
White Face.....	305		

**Precision Measuring Tools 307**

Calipers .....	308	Micrometers .....	310
Indicators.....	309	Gauges .....	311
Precision Measuring Tool Kit.....	309	Brake & Rotor Tools.....	312
Magnetic Bases.....	310		

**Electronic Measuring Tools 313**

Thermometers.....	313		
Meters Digital .....	314-315		

**Mechanic's Tools 316**

Chisel Point Scrapers.....	318	Pry Bars Super Heavy Duty .....	322
Pick, Hook and Scraper Tools.....	319		
Pry Bars Heavy Duty.....	320-321		

**Flashlights 323**

Strongarm Series.....	324		
-----------------------	-----	--	--

**Master Tool Kits 325**

549 Piece Master Tool Kit.....	326-328	211 Piece Mechanic's Starter	
306 Piece Intermediate		Tool Kit.....	331-332
Tool Kit.....	329-330	131 Piece Utility Tool Kit.....	333

**Merchandisers 334**

<b>Display Merchandisers</b>		<b>Pop Displays</b>	
New Hand Tools .....	336-337	Hand Tools.....	343-344
Hand Tools.....	338-341	Specialty Auto.....	345
Specialty Auto.....	342		

**Replacement Wear Parts 346**

Ratchets.....	346-347	Cushion Grip Multi-Bit Driver	
Torque Wrenches .....	348	- Bits .....	349
Pipe Wrenches .....	348	Multi-Bit Drivers	
		- Bits .....	349

**Appendix**

Warranty Policy .....	350		
Numerical Index.....	351-361		
Alphabetical List .....	362-363		



# J E T G R O U P



**STRONGARM**



## WHAT WE DO.

PROFESSIONAL PRODUCTS, ONE SOURCE, MADE EASY.

## OUR MISSION.

An unprecedented, single source portfolio of brands, products and value added services that enable us to earn a leadership position within the professional tool, equipment, shop and safety product markets.

## OUR TEAM.

Committed to providing an unequalled standard of service, support, responsiveness and creativity, that combined will result in a position of preferred status with suppliers, distributors and end customers.

## OUR GOAL.

To make it easier for you to grow the profitability of your business, by partnering with Canada's only single source supplier for branded tools, equipment and safety products.

WE OFFER A TRUE ONE SOURCE PORTFOLIO



## TOOL & EQUIPMENT PORTFOLIO



## SAFETY PORTFOLIO





## New Products

### Check out our new products.

We have added over 200 new products to our catalogue! They are marked with our



symbols making them easy to find.

#### Workbenches pg. 29



#### Shop Carts pg. 28



#### Service Carts pg. 26



#### Open Front Tool Chests pg. 24



#### Tool Organizers pg. 30



#### 3/4" Drive Impact Socket Sets pg. 81



#### Adjustable Wrenches pg. 104 / 105 / 107





## New Products

**Pipe Wrenches** pg. 164 / 165



**Ergonomic Screwdrivers** pg. 127



**VDE Tools** pg. 158



**Cutters** pg. 150 / 151



**Lubrication & Fluid Transfer** pg. 231



**Anti-Fatigue Mats** pg. 217



**Hammers - Indestructible Handle** pg. 176



**Hammers** pg. 172-173







# Tool Storage & Organizers



- PORTABLE TOOL BOXES
- CHESTS AND ROLLER CABINETS
- JOB SITE TOOL STORAGE
- SHOP CARTS
- SERVICE CARTS
- WORKBENCHES
- TOOL BOX ACCESSORIES
- ORGANIZERS



## PORTABLE TOOL BOXES

### Plastic

- Extra thick walls stand up to heavy loads
- Resists scratches and dents, won't rust
- Removable tool tray
- Steel hinge pins for long service life
- 19" and 22" models feature bolt-through carrying handles for extra heavy loads
- Recessed handle for easy storage and transport
- V-groove on lid holds small parts
- Twin heavy duty buckles distribute weight evenly
- Can be padlocked for security

PROD. NO.	MOD. NO.	Width	Depth	Height	Tray Size
<b>842142</b>	JPTB-16	<b>16"</b>	8"	7-1/2"	13-1/2 x 5"
<b>842143</b>	JPTB-19	<b>19"</b>	9"	8"	16-1/4 x 6"
<b>842144</b>	JPTB-22	<b>22"</b>	10-1/4"	9-1/2"	19 x 7-1/4"

### Stainless Steel / Plastic – Heavy Duty

- Combination of stainless steel and plastic components offers great strength with low weight
- Will not rust
- Removable tool tray
- Steel hinge pins for long service life
- Recessed handle for easy storage and transport
- Twin heavy duty steel buckles distribute weight evenly
- Can be padlocked for security

PROD. NO.	MOD. NO.	Width	Depth	Height	Tray Size
<b>842152</b>	JPSTB-15	<b>15"</b>	6-1/4"	7"	13-1/2" x 4-1/2"
<b>842153</b>	JPSTB-20	<b>20"</b>	9-5/8"	8-7/8"	18" x 6-1/2"
<b>842154</b>	JPSTB-22	<b>22-1/2"</b>	11"	10-3/4"	21" x 8"

### Metal - Heavy Duty

- Heavy gauge powder coated steel for durability
- Rust resistant plated buckles
- Pad lock or key lock

PROD. NO.	MOD. NO.	Width	Depth	Height	Overall Weight
<b>842104</b>	TB21	<b>21"</b>	8-3/4"	9"	11 lbs
<b>842105</b>	TB26	<b>26"</b>	8-3/4"	9"	14 lbs
<b>842124</b>	TB21-3	<b>21"</b>	8-3/4"	12"	23 lbs
<b>842134</b>	CTB21-4	<b>21-1/4"</b>	8-3/4"	12"	16 lbs

842142

842143

842144



842152

842153

842154



842104

842124

842134





## SUMO® Series

- SUMO® Series tool storage for professional applications
- Double wall steel construction with reinforced bottom channel on cabinets
- Ball bearing slides on all drawers
- Extruded aluminum drawer pulls
- Heavy duty casters
- Larger chests complete with gas struts for easy opening (42" and 56" only)
- All models complete with drawer liners

## SUMO® Series Mechanic's Chest

### 27" x 18"

6 DRAWERS

842553 / SMC2706

	Width	Depth	Height	Overall Weight
<b>OVERALL</b>	<b>26"</b>	<b>17-7/8"</b>	<b>18-5/16"</b>	<b>38 lbs</b>
6 DRAWERS	<b>23"</b>	<b>16"</b>	<b>2"</b>	

Maximum Load Per Drawer: 75 lbs

## SUMO® Series Roller Cabinet

### 27" x 18"

7 DRAWERS

842503 / SRC2707

	Width	Depth	Height	Overall Weight	Wheels
<b>OVERALL</b>	<b>27"</b>	<b>18-3/4"</b>	<b>35-5/8"</b>	<b>97 lbs</b>	<b>5" x 1-1/4"</b>
4 DRAWERS	<b>23"</b>	<b>16"</b>	<b>2"</b>		2 Swivel
2 DRAWERS	<b>23"</b>	<b>16"</b>	<b>4-1/4"</b>		2 Rigid
1 DRAWER	<b>23"</b>	<b>16"</b>	<b>6-7/16"</b>		

Maximum Load Per Drawer: 75 lbs

# SUMO®



842553

842503



## SUMO® Series Mechanic's Chest

### 42" x 16"

10 DRAWERS

842563 / SMC4210

	Width	Depth	Height	Overall Weight
<b>OVERALL</b>	40-7/8"	16"	19-1/4"	121 lbs
3 DRAWERS	22-1/2"	14"	1-3/4"	
2 DRAWERS	22-1/2"	14"	3-3/4"	
3 DRAWERS	12-1/8"	14"	1-3/4"	
2 DRAWERS	12-1/8"	14"	3-3/4"	

Maximum Load Per Drawer: 100 lbs

### 56" x 24"

6 DRAWERS

842573 / SMC5606

	Width	Depth	Height	Overall Weight
<b>OVERALL</b>	55-1/2"	23-7/8"	19-1/8"	225 lbs
2 DRAWERS	34-5/8"	21-7/8"	4-1/2"	
2 DRAWERS	34-5/8"	21-7/8"	1-5/8"	
1 DRAWER	15-3/8"	21-7/8"	3-5/8"	
1 DRAWER	15-3/8"	21-7/8"	8-3/4"	

Maximum Load Per Drawer: 100 lbs



842563

842513



# SUMO®



842573

842523



## SUMO® Series Roller Cabinets

### 42" x 18"

11 DRAWERS

842513 / SRC4211

	Width	Depth	Height	Overall Weight	Wheels
<b>OVERALL</b>	41-1/2"	18"	39-7/8"	197 lbs	5" x 2"
5 DRAWERS	21-7/8"	15"	2-1/4"		2 Swivel
1 DRAWER	21-7/8"	15"	4-7/8"		2 Rigid
1 DRAWER	36-1/2"	15"	3-7/8"		
2 DRAWERS	12"	15"	2-1/4"		
1 DRAWER	12"	15"	4-7/8"		
1 DRAWER	12"	15"	7-1/2"		

Maximum Load Per Drawer: 100 lbs

### 56" x 24"

10 DRAWERS

842523 / SRC5610

	Width	Depth	Height	Overall Weight	Wheels
<b>OVERALL</b>	56-3/8"	24"	39-1/2"	359 lbs	5" x 2"
1 DRAWER	51-3/8"	20-15/16"	3-1/2"		4 Swivel
2 DRAWERS	34-1/8"	20-15/16"	1-11/16"		2 Rigid
2 DRAWERS	34-1/8"	20-15/16"	3-5/8"		
1 DRAWER	34-1/8"	20-15/16"	4-1/4"		
3 DRAWERS	15"	20-15/16"	1-11/16"		
1 DRAWER	15"	20-15/16"	11-1/8"		

Maximum Load Per Drawer: 100 lbs

## SUMO® Series Side Lockers

- Tall side lockers offer storage for larger tools too high for regular drawers
- Full height design for use with cabinet and chest combinations
- Both lockers include 2 adjustable shelves
- 42" series locker includes one roller bearing drawer
- Designed for use with SUMO® Tool Storage units only

### 42"

SIDE LOCKER

**842542** / SL4202

	Width	Depth	Height	Overall Weight
<b>OVERALL</b>	15-1/2"	18-1/4"	52"	72 lbs
2 SHELVES	15-1/8"	16-3/4"	3/4"	
1 DRAWER	11-1/8"	15-1/4"	2-3/8"	

Side locker for SRC4211

### 56"

SIDE LOCKER

**842543** / SL5602

	Width	Depth	Height	Overall Weight
<b>OVERALL</b>	15-1/2"	24"	51"	66 lbs
2 SHELVES	14-7/8"	22-3/8"	5/8"	

Side locker for SRC5610

# SUMO®

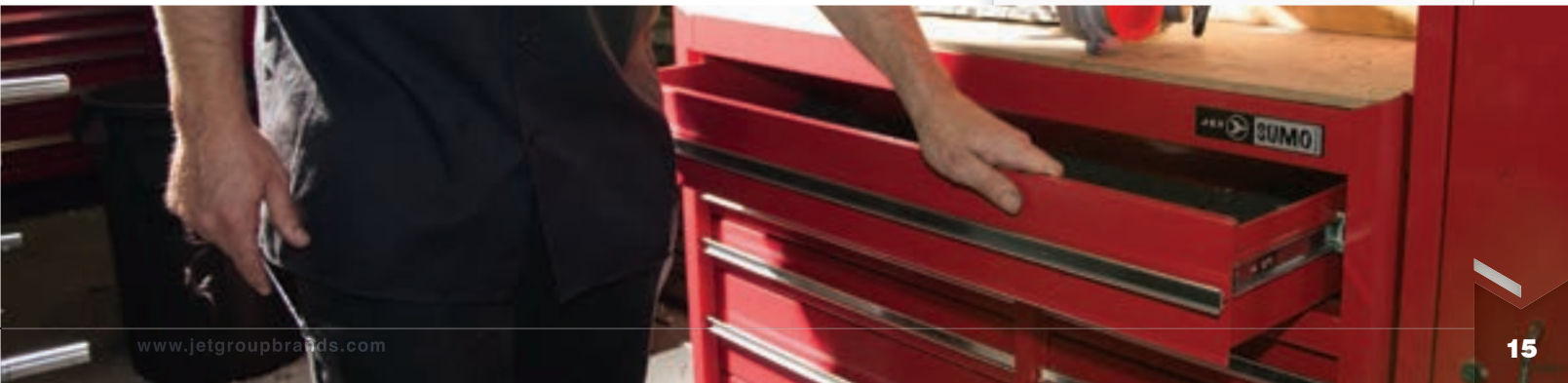

## Black & Gold Series Mechanic's Chests

- Ball bearing slides on all drawers
- Extra heavy gauge steel construction
- Double walls for maximum strength and weight capacity
- Reinforced base and heavy duty casters on all roller cabinets
- Tool tray included with every 27" top chest
- Nickel plated gold look side handles
- Anti-slip drawer liners
- Protective top mat on roller cabinets
- Push-Lock safety drawers stay closed when moving



**26" x 12"**

6 DRAWERS

842652 / MC2606-BG

	Width	Depth	Height	Overall Weight
<b>OVERALL</b>	26"	12"	14-1/2"	49.5 lbs
3 DRAWERS	6-3/4"	10-7/16"	1-7/8"	
2 DRAWERS	22-5/8"	10-7/16"	1-7/8"	
1 DRAWER	22-5/8"	10-7/16"	2-7/16"	

Maximum Load Per Drawer 75 lbs



**26" x 12"**

9 DRAWERS

842654 / MC2609-BG

	Width	Depth	Height	Overall Weight
<b>OVERALL</b>	26"	12"	16-1/2"	57 lbs
6 DRAWERS	6-3/4"	10-7/16"	1-7/8"	
2 DRAWERS	22-5/8"	10-7/16"	1-7/8"	
1 DRAWER	22-5/8"	10-7/16"	2-7/16"	

Maximum Load Per Drawer 75 lbs



**26" x 16"**

6 DRAWERS

842653 / MC2606D-BG

	Width	Depth	Height	Overall Weight
<b>OVERALL</b>	26"	15-7/8"	18-3/4"	72.4 lbs
5 DRAWERS	22-1/2"	14-3/8"	1-7/8"	
1 DRAWER	22-1/2"	14-3/8"	2-3/8"	

Maximum Load Per Drawer 75 lbs



## Black & Gold Series Roller Cabinets

### 27" x 18"

5 DRAWERS

842602 / RC2705-BG

	Width	Depth	Height	Overall Weight	Wheels
<b>OVERALL</b>	27"	18-5/16"	31-5/16"	90 lbs	5"
3 DRAWERS	23"	14-7/8"	2-7/8"		2 swivel
2 DRAWERS	23"	14-7/8"	6"		2 rigid

Maximum Load Per Drawer 75 lbs

### 27" x 18"

7 DRAWERS

842604 / RC2707-BG

	Width	Depth	Height	Overall Weight	Wheels
<b>OVERALL</b>	27"	18-5/16"	37-5/8"	110 lbs	5"
5 DRAWERS	23"	14-7/8"	2-7/8"		2 swivel
2 DRAWERS	23"	14-7/8"	6"		2 rigid

Maximum Load Per Drawer 75 lbs



842613-63



842623-73



## Black & Gold Series Mechanic's Chests



### 41" x 18"

14 DRAWERS

842663 / MC4114-BG

	Width	Depth	Height	Overall Weight
<b>OVERALL</b>	40-5/16	16"	19-1/8"	137 lbs
9 DRAWERS	6-3/4"	14-1/8"	1-7/8"	
2 DRAWERS	22-5/8"	14-1/8"	1-7/8"	
1 DRAWER	22-5/8"	14-1/8"	2-7/16"	
2 DRAWERS	12-3/16"	14-1/8"	5-1/2"	

Maximum Load Per Drawer 100 lbs



### 56" x 24"

9 DRAWERS

842673 / MC5609-BG

	Width	Depth	Height	Overall Weight
<b>OVERALL</b>	55-1/2"	23-7/8"	19-3/8"	225 lbs
7 DRAWERS	25-1/8"	22"	1-7/8"	
1 DRAWER	25-1/8"	22"	4-1/2"	
1 DRAWER	25-1/8"	22"	6-1/2"	

Maximum Load Per Drawer 100 lbs



## Black & Gold Series Roller Cabinets

### 41" x 18"

10 DRAWERS

842613 / RC4110-BG

	Width	Depth	Height	Overall Weight	Wheels
<b>OVERALL</b>	41-1/8"	18-3/8"	39-1/2"	217 lbs	5"
7 DRAWERS	22"	15"	2-7/16"		2 swivel
1 DRAWER	22"	15"	4-7/8"		2 rigid
2 DRAWERS	15-7/8"	15"	2-7/16"		

Maximum Load Per Drawer 100 lbs



### 41" x 18"

16 DRAWERS

842614 / RC4116-BG

	Width	Depth	Height	Overall Weight	Wheels
<b>OVERALL</b>	41-1/8"	18-5/16"	39-5/8"	232 lbs	5"
1 DRAWER	22"	15"	4-7/8"		2 swivel
1 DRAWER	12-1/4"	15"	4-7/8"		2 rigid
7 DRAWERS	22"	15"	2-7/16"		
7 DRAWERS	12-1/4"	15"	2-7/16"		

Maximum Load Per Drawer 100 lbs



### 56" x 24"

13 DRAWERS

842623 / RC5613-BG

	Width	Depth	Height	Overall Weight	Wheels
<b>OVERALL</b>	56"	24"	39-1/2"	446 lbs	5"
10 DRAWERS	24-1/2"	21-1/8"	2-7/16"		2 swivel
2 DRAWERS	24-1/2"	21-1/8"	5"		4 rigid
1 DRAWER	51-5/8"	21-1/8"	3-5/8"		

Maximum Load Per Drawer 100 lbs

## Pro Series Mechanic's Chests

- Two piece friction slides provide long service life
- Full width drawer pulls for comfortable, easy operation
- Full width / full height double wall construction for superior rigidity
- Rear locking mechanism provides maximum security
- Canadian built using the best quality domestic steel for maximum storage capacity without the risk of bending under heavy loads



**26" x 12"**

6 DRAWERS

**842252 / MC26-6**



	Width	Depth	Height	Overall Weight
<b>OVERALL</b>	26"	12"	14-1/2"	55 lbs
3 DRAWERS	7"	10-1/2"	2"	
2 DRAWERS	23"	10-1/2"	2"	
1 DRAWERS	23"	10-1/2"	2-1/2"	

Maximum Load Per Drawer 75 lbs



**26 x 18"**

12 DRAWERS

**842254 / MC26-12**



	Width	Depth	Height	Overall Weight
<b>OVERALL</b>	26"	17-7/8"	20-1/2"	105 lbs
9 DRAWERS	7"	16"	2"	
2 DRAWERS	23"	16"	2"	
1 DRAWER	23"	16"	4-1/4"	

Maximum Load Per Drawer 75 lbs

## Pro Series Roller Cabinets



**27" x 18"**

5 DRAWERS

**842202 / RC27-5**



	Width	Depth	Height	Overall Weight	Wheels
<b>OVERALL</b>	27"	18-3/4"	35-5/8"	109 lbs	5" x 1-1/4"
4 DRAWERS	23"	16"	4-1/4"		2 swivel
1 DRAWER	23"	16"	6-7/16"		2 rigid

Maximum Load Per Drawer 75 lbs



**27" x 18"**

11 DRAWERS

**842204 / RC27-11**



	Width	Depth	Height	Overall Weight	Wheels
<b>OVERALL</b>	27"	18-3/4"	42-3/8"	151 lbs	5" x 2"
4 DRAWERS	11"	16"	2"		2 swivel
4 DRAWERS	23"	16"	2"		2 rigid
2 DRAWERS	23"	16"	4-1/4"		
1 DRAWER	23"	16"	8-1/2"		

Maximum Load Per Drawer 75 lbs

## Pro Series Truck Box

- Extra heavy gauge steel and additional spot welds designed to withstand the constant vibration and bumps of road travel
- Drop front cover with neoprene seal prevents water from entering
- Concealed hinges prevent rust
- Black powder coated paint for long term rust resistance
- Full extension friction drawer slides
- Heavy duty welded side handles with 90° stops
- Heavy duty rubber feet keep box out of water

**26" x 18"**

5 DRAWERS

842256 / TB26-5



	Width	Depth	Height	Overall Weight
<b>OVERALL</b>	26"	17-7/8"	23"	124 lbs
3 DRAWERS	23"	16"	2"	
2 DRAWERS	23"	16"	4-1/4"	

Maximum Load Per Drawer 75 lbs



## JOBSITE TOOL STORAGE

### Jobsite Tool Storage Box - Super Heavy Duty

- Super Heavy Duty 16 gauge steel body and lid for maximum security
- Robotically welded seams for increased strength
- Dual recessed lock housings prevent use of bolt cutters or blades to cut locks
- Staked and welded piano hinge prevents hinge pin from being driven out
- Overlapping lid prevents leaks and features full width reinforcing bolster for added strength
- Finger groove in lid for easy opening even with gloves
- Heavy duty lid stays, prevent accidental closing
- 12 gauge 4-way skids allow forklift access from front, back, and both sides for increased transportation options
- Skids are predrilled to accept optional 6" x 2" heavy duty casters
- High visibility orange powder coat for superior corrosion resistance
- Made in Canada!

**32" x 19"**

JOBSITE TOOL BOX

842480 / JSB-3219

	Width	Depth	Height (without wheels)	Overall Weight
<b>OVERALL</b>	32-1/8"	19"	17-1/2"	70 lbs

Shipping Weight: 72 lbs

**48" x 24"**

JOBSITE TOOL BOX

842481 / JSB-4824

	Width	Depth	Height (without wheels)	Overall Weight
<b>OVERALL</b>	48-1/8"	24-1/8"	28-3/8"	136 lbs

Shipping Weight: 140 lbs



**SITE SAFE**



**MADE IN CANADA**





# TREASURE SERIES



Unique styling stands out in any garage or shop! Dual drop down trays on chest and flip up trays on cabinet provide plenty of work space. Full width aluminum drawer pulls feature safe lock latches to prevent drawers opening when moving tool box

- Ball bearing drawer slides with auto close feature ensure drawers are completely closed before locking
- Safe-Lock system prevents drawers from accidentally opening when moving tool box
- Recessed handles on both sides do not protrude outside of tool box dimensions – easy to park and move!
- Attractive automotive style casters rated to 1,900 lbs total capacity for heavy loads
- All drawers complete with drawer liners
- 5/8" MDF work surface included with roller cabinets
- Secure rear lock mechanism
- Sand finish powder coat paint resists scratches, chemicals, and fingerprints
- A JET Exclusive!



### Treasure Series Tool Chest

#### 41" x 18"

8 DRAWERS

842762 / TMC4208

	Width	Depth	Height	Overall Weight
<b>OVERALL</b>	45-3/4"	18-15/16"	21-5/16"	138 lbs
4 DRAWERS	22-7/16"	15-5/8"	2-15/16"	
4 DRAWERS	12-3/16"	15-5/8"	2-15/16"	
2 SHELVES				

Maximum Load Per Drawer 100 lbs



### Treasure Series Roller Cabinet

#### 41" x 18"

11 DRAWERS

842712 / TRC4211

	Width	Depth	Height	Overall Weight
<b>OVERALL</b>	45-3/4"	18-15/16"	40-1/16"	259 lbs
1 DRAWER	36-13/16"	15-5/8"	4-3/4"	
1 DRAWER	22-7/16"	15-5/8"	6-1/16"	
1 DRAWER	12-1/8"	15-5/8"	12-5/16"	
3 DRAWERS	12-1/8"	15-5/8"	2-5/16"	
5 DRAWERS	22-7/16"	15-5/8"	2-15/16"	
2 SHELVES				

Maximum Load Per Drawer 100 lbs





# TREASURE SERIES

\*\*\*  
BEST



JET  
EXCLUSIVE

## Treasure Series Tool Chest

**53" x 19"**

8 DRAWERS

842772 / TSMC5308

	Width	Depth	Height	Overall Weight
<b>OVERALL</b>	52-13/16"	18-7/8"	21-1/4"	166 lbs
4 DRAWERS	29-5/8"	15-5/8"	3"	
4 DRAWERS	12-1/8"	15-5/8"	3"	
2 SHELVES				

Maximum Load Per Drawer 100 lbs



842772

842722



## Treasure Series Roller Cabinet

**53" x 19"**

12 DRAWERS

842722 / TSRC5312

	Width	Depth	Height	Overall Weight
<b>OVERALL</b>	53"	19-3/32"	33-7/16"	297 lbs
1 DRAWER *	44-1/16"	15-5/8"	4-3/4"	
1 DRAWER *	29-5/8"	15-5/8"	6"	
1 DRAWER *	12-1/8"	15-5/8"	9-1/8"	
4 DRAWERS	12-1/8"	15-5/8"	3"	
5 DRAWERS	29-5/8"	15-5/8"	3"	
2 SHELVES				

Maximum Load Per Drawer 100 lbs with single slides

\* 200 lbs with dual slides





**NEW**

842283



**NEW**

842281



## OPEN FRONT TOOL CHESTS

- Open front design keeps tools organized and visible at a glance, reducing time wasted looking for tools
- All tools are held securely in place when lid is closed – ideal for use on service trucks or atop a roller cabinet or tool cart
- 842281 Extra heavy duty 16 gauge steel with fully welded seams for maximum strength
- 842283 Aluminum diamond plate shell will not chip, peel, or corrode
- No drawer slides to fail during transport even over the roughest roads
- Full weather stripping keeps tools dry and clean in outdoor environments
- Dedicated pegs and holes hold a wide variety of sockets, wrenches, extensions, and screwdrivers
- Additional storage compartments hold other miscellaneous tools
- Socket tray lifts to access tools stored underneath
- Strong two point lock with double sided key for security and convenience
- Gas shock raises lid
- Sturdy side handles for easy movement
- Powder coated for corrosion resistance (except aluminum 842283 model JOFC-26A)
- Complete with compartment liners
- **TOOLS NOT INCLUDED**

### Aluminum Open Front Tool Chest - Super Heavy Duty

**26"**

842283 / JOFC-26A

	Width	Depth	Height	Overall Weight
<b>OVERALL</b>	26-1/4"	17-3/8"	18-3/8"	53.7 lbs

Peg Qty. for 1/4" Dr Socket: **18**

Peg Qty. for 1/4" Dr Deep Socket: **18**

Peg Qty. for 3/8" Dr Socket: **13**

Peg Qty. for 3/8" Dr Deep Socket: **13**

Peg Qty. for 1/2" Dr Socket: **16**

Peg Qty. for 1/2" Dr Deep Socket: **16**

Peg Qty. for Wrenches: **17** (up to 3 per peg)

### Open Front Tool Chest - Super Heavy Duty

**26"**

842281 / JOFC-26

	Width	Depth	Height	Overall Weight
<b>OVERALL</b>	26-1/4"	17-3/8"	18-3/8"	66 lbs

Peg Qty. for 1/4" Dr Socket: **18**

Peg Qty. for 1/4" Dr Deep Socket: **18**

Peg Qty. for 3/8" Dr Socket: **13**

Peg Qty. for 3/8" Dr Deep Socket: **13**

Peg Qty. for 1/2" Dr Socket: **16**

Peg Qty. for 1/2" Dr Deep Socket: **16**

Peg Qty. for Wrenches: **17** (up to 3 per peg)



- Open front design keeps tools organized and visible at a glance, reducing time wasted looking for tools
- All tools are held securely in place when lid is closed – ideal for use on service trucks or atop a roller cabinet or tool cart
- 842281 Extra heavy duty 16 gauge steel with fully welded seams for maximum strength
- 842283 Aluminum diamond plate shell will not chip, peel, or corrode
- No drawer slides to fail during transport even over the roughest roads
- Full weather stripping keeps tools dry and clean in outdoor environments
- Dedicated pegs and holes hold a wide variety of sockets, wrenches, extensions, and screwdrivers
- Additional storage compartments hold other miscellaneous tools
- Socket tray lifts to access tools stored underneath
- Strong two point lock with double sided key for security and convenience
- Gas shock raises lid
- Sturdy side handles for easy movement
- Powder coated for corrosion resistance
- Complete with compartment liners
- **TOOLS NOT INCLUDED**

## Open Front Tool Chests - Super Heavy Duty

### 30"

842284 / JOFC-30

	Width	Depth	Height	Overall Weight
<b>OVERALL</b>	30-3/4"	15-1/4"	18-1/4"	66 lbs

- Peg Qty. for 1/4" Dr Socket: **11**
- Peg Qty. for 1/4" Dr Deep Socket: **11**
- Peg Qty. for 3/8" Dr Socket: **15**
- Peg Qty. for 3/8" Dr Deep Socket: **15**
- Peg Qty. for 1/2" Dr Socket: **18**
- Peg Qty. for 1/2" Dr Deep Socket: **18**
- Peg Qty. for Wrenches: **18** (up to 3 per peg)

### 36"

842286 / JOFC-36

	Width	Depth	Height	Overall Weight
<b>OVERALL</b>	36-7/8"	17-1/2"	21-1/2"	94.2 lbs

- Peg Qty. for 1/4" Dr Socket: **32**
- Peg Qty. for 1/4" Dr Deep Socket: **32**
- Peg Qty. for 3/8" Dr Socket: **28**
- Peg Qty. for 3/8" Dr Deep Socket: **28**
- Peg Qty. for 1/2" Dr Socket: **39**
- Peg Qty. for 1/2" Dr Deep Socket: **40**
- Peg Qty. for Wrenches: **39** (up to 3 per peg)



**NEW**

842284



**NEW**

842286





**NEW**



**NEW**



842916



## SERVICE CARTS

### 4 Drawer Service Cart - Heavy Duty

- Heavy gauge steel shell for professional use
- Ball bearing slides rated for 75 lbs/pair
- 4 drawers, large bottom shelf, and generous under-lid room provide ample storage
- Side tray folds out to provide workspace
- Separate locking screwdriver rack
- Rear drawer lock mechanism for added security
- Lid lays flat against back of cart
- 4 way swivel polyurethane casters
- Comfortable tube steel handle
- Complete with drawer liners

### 30" x 16"

4 DRAWERS

842911 / JTC-30164

	Width	Depth	Height	Overall Weight
<b>OVERALL</b>	35"	17"	32-3/4"	106 lbs
2 DRAWERS	12-3/8"	14-1/2"	2"	
1 DRAWER	26-1/2"	14-1/2"	2"	
1 DRAWER	26-1/2"	14-1/2"	3-1/4"	
SHELF	30"	16"	3"	
UNDER LID	30"	16"	3"	
SIDE SHELF	14"	16"	1/2"	

### 4 Drawer Service Cart - Heavy Duty

- Heavy gauge steel shell for professional use
- Ball bearing slides rated for 75 lbs/pair
- 4 drawers, large bottom shelf, and generous under-lid room provide ample storage
- Drawer slides feature positive retainer system to prevent drawers opening while moving cart
- Long tool storage racks on both sides of cart are secured when lid is locked
- Full height plastic corner bumpers protect automobile finishes from scratches
- Automatic rear drawer lock mechanism engages when lid is closed
- Gas shocks automatically raise lid to open position and unlock all drawers
- 2 fixed and 2 swivel casters with chrome racing style wheels
- Comfortable TPR wrapped oval tube steel handle
- Complete with drawer liners

### 30" x 19"

4 DRAWERS

842916 / JTC-30194

	Width	Depth	Height	Overall Weight
<b>OVERALL</b>	35"	20-1/2"	40-1/2"	121 lbs
2 DRAWERS	12-3/8"	14-1/2"	2"	
1 DRAWER	25-1/2"	17-1/2"	3"	
1 DRAWER	25-1/2"	17-1/2"	6-1/4"	
SHELF	30"	19"	3"	
UNDER LID	30"	19"	6"	

## 4 Drawer Service Cart - Heavy Duty

- Heavy gauge steel shell for professional use
- Ball bearing slides rated for 50 lbs/pair
- 4 drawers, large bottom shelf, and generous under-lid room provide ample storage
- Drawer slides feature positive retainer system to prevent drawers opening while moving cart
- Long tool storage racks on both sides of cart
- Rear drawer lock mechanism for added security
- Gas shocks support lid in open position
- Shocks can be disconnected allowing lid to lay flat against back of cart
- Stiffener plate strengthens lid and prevents warping
- 4 way swivel casters for maximum maneuverability
- Comfortable oval tube steel handle
- Complete with drawer liners

**33" x 18"**

4 DRAWERS

842921 / JTC-33184

	Width	Depth	Height	Overall Weight
<b>OVERALL</b>	36-1/4"	18"	39-1/4"	93 lbs
2 DRAWERS	13-1/2"	15-1/2"	2-1/4"	
1 DRAWER	28-1/4"	15-1/2"	2-1/4"	
1 DRAWER	28-1/4"	15-1/2"	3-1/4"	
SHELF	32-1/4"	17-1/2"	3"	
UNDER LID	32-1/4"	17-1/2"	5"	



**NEW**

BALL BEARING SLIDES

## 4 Drawer Service Cart - Super Heavy Duty

- Extra heavy gauge steel shell for professional use
- Ball bearing slides rated for 100 lbs/pair
- 4 drawers, large bottom shelf, and generous under-lid room provide ample storage
- Raise and Release drawer retainer system prevents drawers opening while moving cart
- Long tool storage racks on both sides of cart are secured when lid is locked
- Rear drawer lock mechanism for added security
- Gas shocks support lid in open position
- Shocks can be disconnected allowing lid to lay flat against back of cart
- Stiffener plate strengthens lid and prevents warping
- 4 way swivel polyurethane casters with chrome wheels for maximum maneuverability and smooth rolling
- Comfortable tube steel handle
- Complete with drawer liners

**NEW**

**SHD**

BALL BEARING SLIDES

**37" x 20"**

4 DRAWERS

842926 / JTC-37204

	Width	Depth	Height	Overall Weight
<b>OVERALL</b>	40-1/2"	21-1/8"	40-1/2"	166 lbs
2 DRAWERS	15"	17"	3"	
1 DRAWER	32-1/4"	17"	3"	
1 DRAWER	32-1/4"	17"	5"	
SHELF	36-1/2"	19-1/2"	3"	
UNDER LID	36-1/2"	19-1/2"	6"	





**NEW**



**NEW**



**NEW**



## SHOP CARTS

- Ideal for garage, office and warehouse applications
- Transport tools around the shop and add much needed workspace
- Heavy gauge steel with enamel finish
- 4 swivel casters (2 free and 2 locking)

### 2 Shelf Shop Cart - Heavy Duty

PROD. NO.	MOD. NO.	Width	Depth	Height	Shipping Weight
<b>842902</b>	JSC-232	32"	17"	36"	38.5 lb (17 kg)

### 3 Shelf Shop Cart - Heavy Duty

PROD. NO.	MOD. NO.	Width	Depth	Height	Shipping Weight
<b>842907</b>	JSC-332	30"	16"	36"	38.5 lb (17 kg)

### Polypropylene Shop Cart - Heavy Duty

- Heavy duty Polypropylene construction supports up to 500 lbs
- Two large 36" x 24" trays with 3" lip keeps items securely on board
- Convenient organizer tray moulded into handle
- Will not dent, rust, chip, or peel
- Resists oil and many chemicals
- 5" x 1" non-marking casters
- Quiet rolling cart is ideal for office use

PROD. NO.	MOD. NO.	Width	Depth	Height	Product Weight
<b>842909</b>	JPTC-3624	46"	25-1/2"	33-1/4"	51 lbs (23kg)

## 3 Shelf Workbench - Heavy Duty

- Top shelf holds up to 1,750 lbs
- Lower shelves hold up to 550 lbs each
- 2" wall around sides and back
- Rolled edges for added strength and rigidity
- Electrostatic oven baked powder coat paint finish
- Top - 3mm rolled edge, Shelves - 2mm rolled edge

PROD. NO.	MOD. NO.	Width	Depth	Height	Shelves
<b>843002</b>	JWB-7925	79"	25"	34-1/2"	3

## 2 Drawer Workbench - Heavy Duty

- Top shelf holds up to 1,750 lbs
- Lower shelf holds up to 550 lbs
- Drawers holds up to 85 lbs each
- Full extension ball bearing drawer slides
- 2" wall around sides and back
- Rolled edges for added strength and rigidity
- Electrostatic over baked powder coat paint finish
- Top - 3mm rolled edge, shelf - 2mm rolled edge

PROD. NO.	MOD. NO.	Width	Depth	Height	Shelves
<b>843003</b>	JWB-5925	59"	25"	34-1/2"	2

## Tear Down Table / Workbench - Heavy Duty

- Fluids drain through table top into a removable plastic container (included)
- Comes with locking storage drawer on ball bearing slides
- Multiple shelf locations gives added versatility
- Square tube leg design gives added strength and stability to table top
- Large 4" heavy duty swivel casters (2 locking)
- Table top features 1/2" rim
- Extra heavy duty construction
- Capacity: 1,000 lbs

PROD. NO.	MOD. NO.	Width	Depth	Height	Shelves
<b>843012</b>	JTTD-1000	47"	31-1/2"	39-3/4"	2

## Folding Portable Workbench

- Great for door/panel body work
- Holds up to 500 lbs
- Padded tops to protect panels
- Folds up for easy storage

PROD. NO.	MOD. NO.	Width	Depth	Height
<b>843004</b>	JFWB-500	40-1/2"	15"	40-1/2"

**NEW**



**NEW**



**NEW**



**NEW**





## TOOL ORGANIZERS

- Aluminum rails with engineered nylon pegs, hooks, and clamps for professional use
- Keeps work space organized for maximum efficiency
- All components resistant to rust, corrosion, and most shop chemicals
- Tool holders can be moved to provide adequate spacing between tools
- Unbreakable in normal use
- Mounting hardware included

**NEW**

841011



841021



841031



\*Tools not included

### Socket Organizers

PROD. NO.	MOD. NO.	Total Pegs	Socket Drive
<b>841011</b>	JWSR-1414	14	1/4"
<b>841021</b>	JWSR-3814	14	3/8"
<b>841031</b>	JWSR-1214	14	1/2"

**NEW**

### 1/4, 3/8, 1/2" Drive Socket Organizer

- Unique socket pegs can be rotated 360° to keep size markings in view
- Spring ball locks sockets onto pegs for use as portable rack or drawer organizer

PROD. NO.	MOD. NO.	Total Pegs	Socket Drive
<b>841151</b>	JTSR-344	44	16 x 1/4", 14 x 3/8", 14 x 1/2"



# TOOL ORGANIZERS



- Aluminum rails with engineered nylon pegs, hooks, and clamps for professional use
- Keeps work space organized for maximum efficiency
- All components resistant to rust, corrosion, and most shop chemicals
- Tool holders can be moved to provide adequate spacing between tools
- Unbreakable in normal use
- Mounting hardware included

**NEW**

## Combination Wrench Organizer

PROD. NO.	MOD. NO.	Total Pegs
<b>841051</b>	JWWR-1200	12



## Screwdriver Organizer

PROD. NO.	MOD. NO.	Total Pegs
<b>841056</b>	JWSDR-1200	12



**NEW**

## Tool Organizer

- Lock knobs keep tool clamps in place allowing customization of rack for many types of tools

PROD. NO.	MOD. NO.	Total Pegs
<b>841061</b>	JWTR-600	6



**NEW**

\*Tools not included







# Ratchet Wrenches



1/4 TO 1" DRIVE RATCHETS  
OVAL/ROUND HEAD  
FLEX HEAD  
TWIST DRIVE RATCHETS  
SWIVEL HEAD RATCHETS  
RATCHET ADAPTORS



670926 - 672927

Includes bonus MHR-3860  
3/8" drive mini head ratchet



690106



670929 - 672929

## 1/4", 3/8" & 1/2" DRIVE

### RHQ Series Oval Head

- All components are forged from superior quality Chrome Vanadium steel
- New increased tooth configurations offer finer ratcheting mechanisms
- Available in regular and extra long models
- Push button quick release feature holds sockets on securely until ready to release
- Convenient reversing switch can be operated with one hand
- Comfortable handle style
- Mirror polish finish
- Repair kits available
- All ratchets are designed for use by professionals
- Meets or exceeds ANSI specifications

PROD. NO.	MOD. NO.	Drive	Length (overall)	Teeth	Quick Release
<b>670926</b>	RHQ-14	<b>1/4"</b>	5-1/2"	48	Yes
<b>670928</b>	RHQ-14L	<b>1/4"</b>	7"	48	Yes
<b>671926</b>	RHQ-38	<b>3/8"</b>	8"	48	Yes
<b>671945</b>	RHQ-38L	<b>3/8"</b>	11-3/4"	48	Yes
<b>672926</b>	RHQ-12	<b>1/2"</b>	10"	48	Yes
<b>672927</b>	RHQ-12L	<b>1/2"</b>	15"	48	Yes



### 3 PC RHQ Series Set

- Contains one each of 1/4, 3/8 and 1/2" RHQ ratchets
- RHQ-3SB oval head set **includes bonus MHR-3860 3/8" drive mini head ratchet!**

PROD. NO.	MOD. NO.	Drive	Pieces	Teeth	Quick Release
<b>690106</b>	RHQ-3SB	<b>1/4, 3/8, 1/2"</b>	3	48/60	Yes



### RHQ-F Series Oval Head - Heavy Duty

- Flex head feature allows access into awkward locations
- Same quality features as our RHQ series

PROD. NO.	MOD. NO.	Drive	Length (overall)	Teeth	Quick Release
<b>670929</b>	RHQ-14F	<b>1/4"</b>	6-1/4"	48	Yes
<b>671942</b>	RHQ-38FS	<b>3/8"</b>	4-1/2"	48	Yes
<b>671943</b>	RHQ-38F2	<b>3/8"</b>	11-1/2"	48	Yes
<b>672929</b>	RHQ-12F	<b>1/2"</b>	17-1/2"	48	Yes

Replacement repair kits listed in the back of the catalogue

# 1/4", 3/8" & 1/2" DRIVE



## HT72 Series High Torque

- All metal components are forged from superior quality Chrome Vanadium steel
- High torque 72 tooth twin pawl ratcheting system exceeds ANSI standards for torque
- 5° maximum movement between each engagement of teeth
- Push button quick release feature holds sockets on securely until ready to release
- Comfortable ergonomic handle design with anti-slip strips improves gripping power and reduces operator fatigue
- Spinner ring for use in areas with restricted space
- Convenient hanging hole
- Patented offset ratchet handle offers unique safety features - reduces knuckle damage and improves socket positioning
- Repair kits available

PROD. NO.	MOD. NO.	Drive	Length (overall)	Teeth	Quick Release
670927	HT-1472	1/4"	5-1/2"	72	Yes
671928	HT-3872	3/8"	7-3/4"	72	Yes
672928	HT-1272	1/2"	10"	72	Yes



## 3 PC HT72 Series Set

690104 / HT-72S

- Contains 1 each: 1/4, 3/8 and 1/2" ratchets above



671928

Super strong twin pawl ratcheting system



Replacement repair kits listed in the back of the catalogue



671923

672922

671922

670922



890512

## 1/4", 3/8" & 1/2" DRIVE

### Twist Drive Ratchets

- Patented Twist Drive action drives sockets without swinging handle - 0° swing arc!
- Special design drives socket in one direction while twisting handle in both directions
- Allows for super fast running of fasteners when space is limited
- Works like a regular ratchet for additional torque
- Co-moulded handle materials provide all day comfort and non-slip grip
- Chrome Vanadium steel handle with Chrome Molybdenum drive gears for maximum strength
- Available in 6 piece POP display

PROD. NO.	MOD. NO.	Drive	Length (overall)	Teeth
<b>671923</b>	TD-3860	<b>3/8"</b>	9-1/4"	60
<b>672923</b>	TD-1260	<b>1/2"</b>	11-1/2"	60



### 270° Swivel Head Ratchets

- Unique 270° rotating head provides ultimate flex head function
- Only the head rotates, providing maximum flex positions while maintaining smallest profile
- 72 tooth quick release ratchet head requires only 5° swing room
- Convenient direction switch on head is accessible from any angle
- Chrome Vanadium steel handle with Chrome Molybdenum drive gears
- Co-moulded handle grip provides all day comfort and sure grip
- Available in 9 piece POP display (3 of each drive size) - **890512**

PROD. NO.	MOD. NO.	Drive	Length (overall)	Teeth	Quick Release
<b>670922</b>	SH270-14	<b>1/4"</b>	5-7/8"	72	Yes
<b>671922</b>	SH270-38	<b>3/8"</b>	9-1/4"	72	Yes
<b>672922</b>	SH270-12	<b>1/2"</b>	11-7/8"	72	Yes



Head Swivels 270°

Replacement repair kits listed in the back of the catalogue

# 1/4", 3/8" & 1/2" DRIVE



## Special Purpose Ratchets

### Mini Head Ratchet Wrench

671941

- Mini head and ultra slim body design allows access into confined areas
- Smooth, 60 tooth ratcheting action offers an extremely small swing area - 6°
- Push button quick release
- Full polish, mirror finish



Mini Head

### Articulating Head Ratchet Wrench

671944

- 3/8" drive ratchet head rotates around articulating joint, providing up to 8x the speed of a regular ratchet
- Rotating head can be locked in any position to clear obstacles and provide maximum access
- 6140 Chrome Vanadium steel for professional use
- Mirror polished finish
- Meets ANSI torque rating for 3/8" drive ratchets



Articulating Joint

PROD. NO.	MOD. NO.	Drive	Length (overall)	Teeth	Quick Release
671941	MHR-3872	3/8"	7-3/4"	60	Yes
671944	HSR-3800	3/8"	10-1/4"	48	Yes



## 4 Piece Ratchet Wrench Adaptor Set

701196 / RWAS-4

- 1/4", 3/8", and 1/2" socket adaptors and 1/4" hex bit adaptor provide maximum versatility by turning your ratcheting wrench set into a full wrench, bit, and socket drive set
- Converts the wrench into an extremely low profile ratchet for access to the most limited spaces
- Works with flat, reversing, and flex head ratcheting combination wrenches
- Requires 3/8", 1/2", and 3/4" ratcheting wrenches (sold separately)
- Available in 4 pc set only

### CONTENTS:

- **1/4" hex bit adaptor** for use with 3/8" ratcheting wrench
- **1/4" drive socket adaptor** for use with 3/8" ratcheting wrench
- **3/8" drive socket adaptor** for use with 1/2" ratcheting wrench
- **1/2" drive socket adaptor** for use with 3/4" ratcheting wrench
- Ratcheting wrenches sold separately



Replacement repair kits listed in the back of the catalogue



671941

Push Button Quick Release



671944

JET EXCLUSIVE



Adaptor set converts ratcheting combination wrenches to socket or bit drivers



Socket adaptors complete with quick release feature



JET ratcheting adaptors provide the most versatile system for all your ratcheting needs.

*These adaptors can be used with:*

### 1. All lengths of flex bars



### 2. Sliding T-Bars



### 3. Socket Extensions

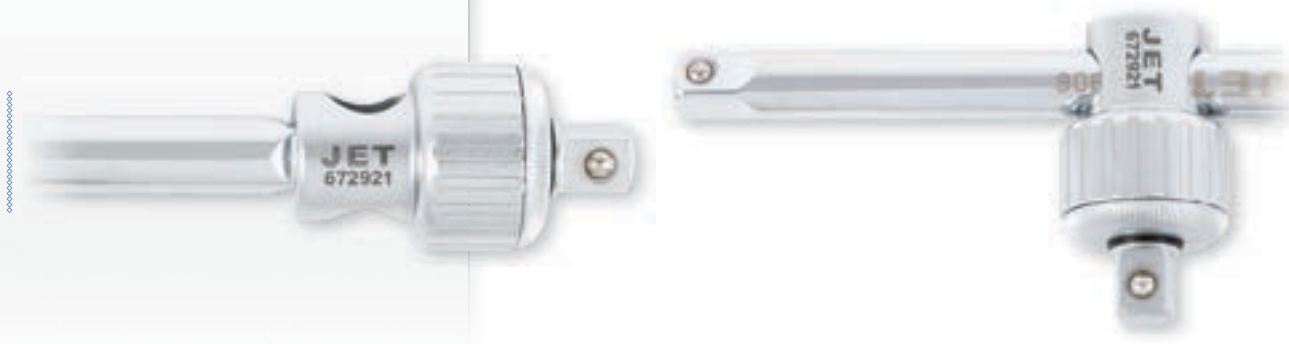

## 1/4", 3/8" & 1/2" DRIVE

### Ratcheting Adaptors

- 3 way ratcheting adaptors turn any suitably sized flex bar, sliding T-Bar, or extension bar into a reversible ratchet
- Square drive hole plus round through hole allows use with most drive tools
- Can also be used as a finger ratchet
- Chrome Vanadium steel with Chrome Molybdenum drive anvil for maximum strength
- 52 teeth requires just 7° swing arc for use in very close quarters
- Blow mould case



PROD. NO.	MOD. NO.	Drive	Pieces
-----------	----------	-------	--------

#### 3 PIECE SET

690107	RA352	1/4", 3/8", 1/2"	3
--------	-------	------------------	---

#### OPEN STOCK

670921	RA1452	1/4"	Open Stock
671921	RA3852	3/8"	Open Stock
672921	RA1252	1/2"	Open Stock



## RH Series

- ANSI rated
- Repair kits available
- Professional quality at an economical price

PROD. NO.	MOD. NO.	Drive	Length (overall)	Teeth	Quick Release
<b>673901</b>	RH-75	<b>3/4"</b>	20"	42	No
<b>674901</b>	RH-100	<b>1"</b>	26"	24	No

## RHQ Series Oval Head - Heavy Duty

PROD. NO.	MOD. NO.	Drive	Length (overall)	Teeth	Quick Release
<b>673922</b>	RHQ-34	<b>3/4"</b>	19-1/2"	24	Yes



673901

674901

## HT72 Series High Torque - Heavy Duty

- 72 teeth require just 5° swing room to engage next tooth
- Ideal for fasteners in restricted areas
- Extra heavy pawl spring keeps 8 teeth engaged at all times for maximum strength
- Quick release feature locks accessories to ratchet
- One piece drop forged head and handle

PROD. NO.	MOD. NO.	Drive	Length (overall)	Teeth	Quick Release
<b>673924</b>	HT-3472	<b>3/4"</b>	20"	72	Yes



673922

Push Button Quick Release



Push Button Quick Release

673924

Replacement repair kits listed in the back of the catalogue



## 3/4" & 1" DRIVE

### RHD Series - Super Heavy Duty

- All components made from the best quality Chrome Vanadium steel
- Designed to withstand the toughest applications
- Handles sold separately



### Heads

PROD. NO.	MOD. NO.	Drive	Teeth	Quick Release
<b>673923</b>	RHD3400	<b>3/4"</b>	40	No
<b>674906</b>	RHD1036	<b>1"</b>	36	No



### Handles

PROD. NO.	MOD. NO.	Length (overall)
<b>673913</b>	DH3400	20" for 673923 (RHD3400), 673910 (SA7509), 673911 (SA7510)
<b>673914</b>	TDH3400	20" - 32" for 673923 (RHD3400), 673910 (SA7509), 673911 (SA7510)
<b>674907</b>	DH1036	25" for 677906 (RHD1036)



674906

673923

For 3/4" heads



673913

20 - 32"



673914

For 1" heads



674907

Replacement repair kits listed in the back of the catalogue





# Chrome Sockets

1/4 TO 1" DRIVE  
SOCKET SETS  
OPEN STOCK  
HEX, TORX®  
AND EXTERNAL TORX® BITS  
ACCESSORIES



**TORQUE DRIVE**



# 1/4" DR SOCKET WRENCH SETS

▼ *Hand Tools shown in this section feature:*

- All components forged from high quality Chrome Vanadium steel
- TORQUE DRIVE® sockets contact the fastener on the sides rather than the corners, reducing corner rounding and allowing 20% more torque
- Chamfered edges allow easiest socket placement on fastener, increasing productivity and reducing frustration
- Extra long deep sockets ensure maximum accessibility
- Meets or exceeds U.S. Federal Specs: GGG-W-641E and Canadian Government Specs: CDA39-GP-12b and ANSI specifications

**24 PC S.A.E. - 6 Point**

**600115 / SW1424-6**

*STANDARD LENGTH S.A.E.*

**3/16, 7/32, 1/4, 9/32, 5/16, 11/32, 3/8, 7/16, 1/2"**

*DEEP LENGTH S.A.E.*

**3/16, 7/32, 1/4, 9/32, 5/16, 11/32, 3/8, 7/16, 1/2"**

*STANDARD ACCESSORIES:*

- 48 tooth 5-1/2" quick release oval head ratchet (**670926**)
- 2" (**670904**) and 6" (**670906**) extensions
- 6" spinner handle (**670912**)
- 1-3/8" universal joint (**670908**)
- Blow mould case with removable lid



**28 PC Metric - 6 Point**

**600116 / SW1428M-6**

*STANDARD LENGTH METRIC*

**4, 5, 5.5, 6, 7, 8, 9, 10, 11, 12, 13mm**

*DEEP LENGTH METRIC*

**4, 5, 5.5, 6, 7, 8, 9, 10, 11, 12, 13mm**

*STANDARD ACCESSORIES:*

- 48 tooth 5-1/2" quick release oval head ratchet (**670926**)
- 2" (**670904**) and 6" (**670906**) extensions
- 6" spinner handle (**670912**)
- 1-3/8" universal joint (**670908**)
- Blow mould case with removable lid



**WARNING:** Do not use chrome sockets on impact wrenches

## TORQUE DRIVE

### 42 PC S.A.E./Metric - 6 Point

600125 / SW1442C-6

STANDARD LENGTH S.A.E.

**3/16, 7/32, 1/4, 9/32, 5/16, 11/32, 3/8, 7/16, 1/2"**

DEEP LENGTH S.A.E.

**3/16, 7/32, 1/4, 9/32, 5/16, 11/32, 3/8, 7/16, 1/2"**

STANDARD LENGTH METRIC

**4, 5, 6, 7, 8, 9, 10, 11, 12mm**

DEEP LENGTH METRIC

**4, 5, 6, 7, 8, 9, 10, 11, 12mm**

STANDARD ACCESSORIES:

- 72 tooth high torque ratchet (**670927**)
- 2" (**670904**) and 4" (**670915**) extensions
- 6" spinner handle (**670912**)
- 1-3/8" universal joint (**670908**)
- Blow mould case with removable lid



### 42 PC S.A.E./Metric - 12 Point

600126 / SW1442C-12

STANDARD LENGTH S.A.E.

**3/16, 7/32, 1/4, 9/32, 5/16, 11/32, 3/8, 7/16, 1/2"**

DEEP LENGTH S.A.E.

**3/16, 7/32, 1/4, 9/32, 5/16, 11/32, 3/8, 7/16, 1/2"**

STANDARD LENGTH METRIC

**4, 5, 6, 7, 8, 9, 10, 11, 12mm**

DEEP LENGTH METRIC

**4, 5, 6, 7, 8, 9, 10, 11, 12mm**

STANDARD ACCESSORIES:

- 72 tooth high torque ratchet (**670927**)
- 2" (**670904**) and 4" (**670915**) extensions
- 6" spinner handle (**670912**)
- 1-3/8" universal joint (**670908**)
- Blow mould case with removable lid



**WARNING:** Do not use chrome sockets on impact wrenches



## TORQUE DRIVE



# 3/8" DR SOCKET WRENCH SETS

▼ *Hand Tools shown in this section feature:*

- All components forged from high quality Chrome Vanadium steel
- TORQUE DRIVE® sockets contact the fastener on the sides rather than the corners, reducing corner rounding and allowing 20% more torque
- Chamfered edges allow easiest socket placement on fastener, increasing productivity and reducing frustration
- Extra long deep sockets ensure maximum accessibility
- Meets or exceeds U.S. Federal Specs: GGG-W-641E and Canadian Government Specs: CDA39-GP-12b and ANSI specifications

### 11 PC S.A.E. - 6 Point

600223 / SW3811-6

STANDARD LENGTH S.A.E.

5/16, 3/8, 7/16, 1/2, 9/16, 5/8, 11/16, 3/4"

STANDARD ACCESSORIES:

- 48 tooth 8" quick release oval head ratchet (671926)
- 6" extension (671907)
- Blow mould case



### 15 PC Metric - 6 Point

600226 / SW3815M-6

STANDARD LENGTH METRIC

8, 9, 10, 11, 12, 13, 14, 15, 16, 17, 18, 19mm

STANDARD ACCESSORIES:

- 48 tooth 8" quick release oval head ratchet (671926)
- 6" extension (671907)
- Blow mould case



### 21 PC S.A.E. - 6 Point

600229 / SW3821-6

STANDARD LENGTH S.A.E.

3/8, 7/16, 1/2, 9/16, 5/8, 11/16, 3/4"

DEEP LENGTH S.A.E.

3/8, 7/16, 1/2, 9/16, 5/8, 11/16, 3/4, 13/16"

STANDARD ACCESSORIES:

- 48 tooth 8" quick release oval head ratchet (671926)
- 3" (671905) and 6" (671907) extensions
- 8" flex handle (671902)
- 1-7/8" universal joint (671910)
- Blow mould case with removable lid



**WARNING:** Do not use chrome sockets on impact wrenches

# 3/8" DR SOCKET WRENCH SETS



## 30 PC Metric - 6 Point

600234 / SW3830M-6

STANDARD LENGTH METRIC

8, 9, 10, 11, 12, 13, 14, 15, 16, 17, 18, 19mm

DEEP LENGTH METRIC

8, 9, 10, 11, 12, 13, 14, 15, 16, 17, 18, 19mm

STANDARD ACCESSORIES:

- 48 tooth 8" quick release oval head ratchet (671926)
- 3" (671905) and 6" (671907) extensions
- 8" flex handle (671902)
- 1-7/8" universal joint (671910)
- Blow mould case with removable lid



## 45 PC S.A.E./Metric - 6 Point

600241 / SW3845C-6

STANDARD LENGTH S.A.E.

3/8, 7/16, 1/2, 9/16, 5/8, 11/16, 3/4"

DEEP LENGTH S.A.E.

3/8, 7/16, 1/2, 9/16, 5/8, 11/16, 3/4, 13/16"

STANDARD LENGTH METRIC

8, 9, 10, 11, 12, 13, 14, 15, 16, 17, 18, 19mm

DEEP LENGTH METRIC

8, 9, 10, 11, 12, 13, 14, 15, 16, 17, 18, 19mm

STANDARD ACCESSORIES:

- 72 tooth high torque ratchet (671928)
- 3" (671905) and 6" (671907) extensions
- 8" flex handle (671902)
- 1-7/8" universal joint (671910)
- Blow mould case with removable lid



## 45 PC S.A.E./Metric - 12 Point

600242 / SW3845C-12

STANDARD LENGTH S.A.E.

3/8, 7/16, 1/2, 9/16, 5/8, 11/16, 3/4"

DEEP LENGTH S.A.E.

3/8, 7/16, 1/2, 9/16, 5/8, 11/16, 3/4, 13/16"

STANDARD LENGTH METRIC

8, 9, 10, 11, 12, 13, 14, 15, 16, 17, 18, 19mm

DEEP LENGTH METRIC

8, 9, 10, 11, 12, 13, 14, 15, 16, 17, 18, 19mm

STANDARD ACCESSORIES:

- 72 tooth high torque ratchet (671928)
- 3" (671905) and 6" (671907) extensions
- 8" flex handle (671902)
- 1-7/8" universal joint (671910)
- Blow mould case with removable lid



### TORQUE DRIVE



**WARNING:** Do not use chrome sockets on impact wrenches



# HEAT TREATED FOR PROFESSIONAL USE

## TORQUE DRIVE®



### 1/2" DR SOCKET WRENCH SETS

▼ *Hand Tools shown in this section feature:*

- All components forged from high quality Chrome Vanadium steel
- TORQUE DRIVE® sockets contact the fastener on the sides rather than the corners, reducing corner rounding and allowing 20% more torque
- Chamfered edges allow easiest socket placement on fastener, increasing productivity and reducing frustration
- Extra long deep sockets ensure maximum accessibility
- Meets or exceeds U.S. Federal Specs: GGG-W-641E and Canadian Government Specs: CDA39-GP-12b and ANSI specifications

#### 19 PC Metric - 6 Point

600326 / SW1219M-6

STANDARD LENGTH METRIC

12, 13, 14, 15, 16, 17, 18, 19, 20, 21, 22, 23, 24mm

STANDARD ACCESSORIES:

- 48 tooth 10" quick release oval head ratchet (672926)
- 5" (672905) and 10" (672906) extensions
- 15" flex handle (672903)
- 2-3/4" universal joint (672908)
- Blow mould case with removable lid



#### 20 PC S.A.E. - 6 Point

600323 / SW1220-6

STANDARD LENGTH S.A.E.

7/16, 1/2, 9/16, 5/8, 11/16, 3/4, 13/16, 7/8, 15/16, 1, 1-1/16, 1-1/8, 1-3/16, 1-1/4"

STANDARD ACCESSORIES:

- 48 tooth 10" quick release oval head ratchet (672926)
- 5" (672905) and 10" (672906) extensions
- 15" flex handle (672903)
- 2-3/4" universal joint (672908)
- Blow mould case



**⚠ WARNING:** Do not use chrome sockets on impact wrenches

# HIGH QUALITY CHROME VANADIUM STEEL

## 1/2" DR SOCKET WRENCH SETS

### 29 PC S.A.E. - 6 Point

600331 / SW1229-6

#### STANDARD LENGTH S.A.E.

3/8, 7/16, 1/2, 9/16, 5/8, 11/16, 3/4, 13/16, 7/8, 15/16,  
1, 1-1/16, 1-1/8, 1-3/16, 1-1/4"

#### DEEP LENGTH S.A.E.

7/16, 1/2, 9/16, 5/8, 11/16, 3/4, 7/8"

#### STANDARD ACCESSORIES:

- 48 tooth 10" quick release oval head ratchet (672926)
- 2" (672904), 5" (672905) and 10" (672906) extensions
- 10" sliding T-handle (672907)
- 2-3/4" universal joint (672908)
- Blow mould case with removable lid



## TORQUE DRIVE



### 55 PC S.A.E./Metric - 6 Point

600341 / SW1255C-6

#### STANDARD LENGTH S.A.E.

3/8, 7/16, 1/2, 9/16, 5/8, 11/16, 3/4, 13/16, 7/8,  
15/16, 1, 1-1/16, 1-1/8, 1-3/16, 1-1/4"

#### DEEP LENGTH S.A.E.

7/16, 1/2, 9/16, 5/8, 11/16, 3/4, 7/8"

#### STANDARD LENGTH METRIC

10, 11, 12, 13, 14, 15, 16, 17, 18, 19, 21, 22, 23, 24,  
27, 30, 32mm

#### DEEP LENGTH METRIC

10, 12, 13, 14, 15, 16, 17, 18, 19, 21mm

#### STANDARD ACCESSORIES:

- 72 tooth high torque ratchet (672928)
- 2" (672904), 5" (672905) and 10" (672906) extensions
- 10" sliding T-handle (672907)
- 2-3/4" universal joint (672908)
- Blow mould case with removable lid



**WARNING:** Do not use chrome sockets on impact wrenches



## TORQUE DRIVE



## 3/4" DR SOCKET WRENCH SETS

▼ Hand Tools shown in this section feature:

- All components forged from high quality Chrome Vanadium steel
- Chamfered edges allow easiest socket placement on fastener, increasing productivity and reducing frustration
- Meets or exceeds U.S. Federal Specs: GGG-W-641E and Canadian Government Specs: CDA39-GP-12b and ANSI specifications

### 7 PC Telescopic Tool Set

690105 / SDK3407

STANDARD ACCESSORIES:

- 40 tooth super duty reversible ratchet (673923)
- 20-32" telescoping drive handle (for use with all items in kit) (673914)
- 4" extension (673903)
- 3/4" Female x 1" Male adaptor (673912)
- Sliding T-handle head (673910)
- Flex joint head (673911)
- Blow mould case



### 21 PC S.A.E. - 12 Point

600402 / SW7521

STANDARD LENGTH S.A.E.

3/4, 7/8, 15/16, 1, 1-1/16, 1-1/8, 1-3/16, 1-1/4, 1-5/16, 1-3/8, 1-7/16, 1-1/2, 1-5/8, 1-3/4, 1-7/8, 2"

STANDARD ACCESSORIES:

- 42 tooth 20" round head ratchet (673901)
- 4" (673903) and 8" (673904) extensions
- 18" sliding T-handle (673906)
- Metal case



### 21 PC S.A.E. - 12 Point

600406 / SW7521-HD

STANDARD LENGTH S.A.E.

3/4, 7/8, 15/16, 1, 1-1/16, 1-1/8, 1-3/16, 1-1/4, 1-5/16, 1-3/8, 1-7/16, 1-1/2, 1-5/8, 1-3/4, 1-7/8, 2"

STANDARD ACCESSORIES:

- 24 tooth 19-1/2" deluxe oval head ratchet (673922)
- 4" (673903) and 8" (673904) extensions
- 18" sliding T-handle (673906)
- Blow mould case



Heavy Duty Ratchet

**WARNING:** Do not use chrome sockets on impact wrenches



# 1" DR SOCKET WRENCH SETS



▼ *Hand Tools shown in this section feature:*

- All components forged from high quality Chrome Vanadium steel
- TORQUE DRIVE® sockets contact the fastener on the sides rather than the corners, reducing corner rounding and allowing 20% more torque
- Chamfered edges allow easiest socket placement on fastener, increasing productivity and reducing frustration
- Extra long deep sockets ensure maximum accessibility
- Meets or exceeds U.S. Federal Specs: GGG-W-641E and Canadian Government Specs: CDA39-GP-12b and ANSI specifications

**TORQUE DRIVE**®

## 17 PC S.A.E. - 12 Point

600505 / SW1017

*STANDARD LENGTH S.A.E.*

**1-7/16, 1-1/2, 1-5/8, 1-11/16, 1-3/4, 1-7/8, 2, 2-3/16, 2-1/4, 2-3/8, 2-1/2"**

*STANDARD ACCESSORIES:*

- 24 tooth heavy duty reversible ratchet head (**674901**)
- 8" (**674905**) and 16" (**674903**) extensions
- 22" universal handle (included with **674901**)
- Sliding T-head
- Metal case



## 21 PC S.A.E. - 12 Point

600503 / SW1021

*STANDARD LENGTH S.A.E.*

**1-7/16, 1-1/2, 1-5/8, 1-11/16, 1-3/4, 1-13/16, 1-7/8, 2, 2-1/8, 2-3/16, 2-1/4, 2-3/8, 2-1/2, 2-5/8, 2-3/4, 2-15/16, 3-1/8"**

*STANDARD ACCESSORIES:*

- 24 tooth heavy duty reversible ratchet head (**674901**)
- 8" (**674905**) and 16" (**674903**) extensions
- 22" universal handle (included with **674901**)
- Sliding T-head
- Metal case



 **WARNING:** Do not use chrome sockets on impact wrenches



**TORQUE DRIVE**

## 1/4" DR SOCKET SETS

▼ *Hand Tools shown in this section feature:*

- All components forged from high quality Chrome Vanadium steel
- TORQUE DRIVE® sockets contact the fastener on the sides rather than the corners, reducing corner rounding and allowing 20% more torque
- Chamfered edges allow easiest socket placement on fastener, increasing productivity and reducing frustration
- Extra long deep sockets ensure maximum accessibility
- Meets or exceeds U.S. Federal Specs: GGG-W-641E and Canadian Government Specs: CDA39-GP-12b and ANSI specifications



### 9 PC S.A.E - 6 Point

601102 / SS1409-6

STANDARD LENGTH S.A.E.

3/16, 7/32, 1/4, 9/32, 5/16, 11/32, 3/8, 7/16, 1/2"

- Includes socket rail

6 CrV



### 9 PC Deep S.A.E. - 6 Point

601107 / SS1409D-6

DEEP LENGTH S.A.E.

3/16, 7/32, 1/4, 9/32, 5/16, 11/32, 3/8, 7/16, 1/2"

- Includes socket rail

6 CrV



### 11 PC Metric - 6 Point

601113 / SS1411M-6

STANDARD LENGTH METRIC

4, 5, 5.5, 6, 7, 8, 9, 10, 11, 12, 13mm

- Includes socket rail

6 CrV



### 11 PC Deep Metric - 6 Point

601118 / SS1411DM-6

DEEP LENGTH METRIC

4, 5, 5.5, 6, 7, 8, 9, 10, 11, 12, 13mm

- Includes socket rail

6 CrV

**⚠ WARNING:** Do not use chrome sockets on impact wrenches

# 3/8" DR SOCKET SETS



▼ *Hand Tools shown in this section feature:*

- All components forged from high quality Chrome Vanadium steel
- TORQUE DRIVE® sockets contact the fastener on the sides rather than the corners, reducing corner rounding and allowing 20% more torque
- Chamfered edges allow easiest socket placement on fastener, increasing productivity and reducing frustration
- Extra long deep sockets ensure maximum accessibility
- Meets or exceeds U.S. Federal Specs: GGG-W-641E and Canadian Government Specs: CDA39-GP-12b and ANSI specifications



3/8" DRIVE SPARK PLUG SOCKETS  
See page 60 for special  
5 PC Spark Plug Socket Set

## 8 PC S.A.E. - 6 Point

601219 / SS3808-6

STANDARD LENGTH S.A.E.

5/16, 3/8, 7/16, 1/2, 9/16, 5/8, 11/16, 3/4"

- Includes socket rail



## 8 PC Deep S.A.E. - 6 Point

601220 / SS3808D-6

DEEP LENGTH S.A.E.

3/8, 7/16, 1/2, 9/16, 5/8, 11/16, 3/4, 13/16"

- Includes socket rail



## 9 PC S.A.E. - 12 Point

601227 / SS3809-12

STANDARD LENGTH S.A.E.

1/4, 5/16, 3/8, 7/16, 1/2, 9/16, 5/8, 11/16, 3/4"

- Includes socket rail



## 9 PC Deep S.A.E. - 12 Point

601229 / SS3809D-12

DEEP LENGTH S.A.E.

1/4, 5/16, 3/8, 7/16, 1/2, 9/16, 5/8, 11/16, 3/4"

- Includes socket rail



**WARNING:** Do not use chrome sockets on impact wrenches



**TORQUE DRIVE**

## 3/8" DR SOCKET SETS

▼ *Hand Tools shown in this section feature:*

- All components forged from high quality Chrome Vanadium steel
- TORQUE DRIVE® sockets contact the fastener on the sides rather than the corners, reducing corner rounding and allowing 20% more torque
- Chamfered edges allow easiest socket placement on fastener, increasing productivity and reducing frustration
- Extra long deep sockets ensure maximum accessibility
- Meets or exceeds U.S. Federal Specs: GGG-W-641E and Canadian Government Specs: CDA39-GP-12b and ANSI specifications



### 12 PC Metric - 6 Point

601224 / SS3812M-6

STANDARD LENGTH METRIC

8, 9, 10, 11, 12, 13, 14, 15, 16, 17, 18, 19mm

- Includes socket rail

**6 CrV**



### 12 PC Metric - 12 Point

601234 / SS3812M-12

STANDARD LENGTH METRIC

8, 9, 10, 11, 12, 13, 14, 15, 16, 17, 18, 19mm

- Includes socket rail

**12 CrV**



### 12 PC Deep Metric - 6 Point

601226 / SS3812DM-6

DEEP LENGTH METRIC

8, 9, 10, 11, 12, 13, 14, 15, 16, 17, 18, 19mm

- Includes socket rail

**6 CrV**



### 12 PC Deep Metric - 12 Point

601236 / SS3812DM-12

DEEP LENGTH METRIC

8, 9, 10, 11, 12, 13, 14, 15, 16, 17, 18, 19mm

- Includes socket rail

**12 CrV**

**⚠ WARNING:** Do not use chrome sockets on impact wrenches

# 1/2" DR SOCKET SETS



▼ *Hand Tools shown in this section feature:*

- All components forged from high quality Chrome Vanadium steel
- TORQUE DRIVE® sockets contact the fastener on the sides rather than the corners, reducing corner rounding and allowing 20% more torque
- Chamfered edges allow easiest socket placement on fastener, increasing productivity and reducing frustration
- Extra long deep sockets ensure maximum accessibility
- Meets or exceeds U.S. Federal Specs: GGG-W-641E and Canadian Government Specs: CDA39-GP-12b and ANSI specifications



## 15 PC S.A.E. - 6 Point

601316 / SS1215-6

STANDARD LENGTH S.A.E.

3/8, 7/16, 1/2, 9/16, 5/8, 11/16, 3/4, 13/16, 7/8, 15/16, 1, 1-1/16, 1-1/8, 1-3/16, 1-1/4"

- Includes socket rail



## 15 PC S.A.E. - 12 Point

601317 / SS1215-12

STANDARD LENGTH S.A.E.

3/8, 7/16, 1/2, 9/16, 5/8, 11/16, 3/4, 13/16, 7/8, 15/16, 1, 1-1/16, 1-1/8, 1-3/16, 1-1/4"

- Includes socket rail



## 13 PC Deep S.A.E. - 6 Point

601313 / SS1213D-6

DEEP LENGTH S.A.E.

7/16, 1/2, 9/16, 5/8, 11/16, 3/4, 13/16, 7/8, 15/16, 1, 1-1/16, 1-1/8, 1-1/4"

- Includes socket rail



## 13 PC Deep S.A.E. - 12 Point

601318 / SS1213D-12

DEEP LENGTH S.A.E.

7/16, 1/2, 9/16, 5/8, 11/16, 3/4, 13/16, 7/8, 15/16, 1, 1-1/16, 1-1/8, 1-1/4"

- Includes socket rail



**WARNING:** Do not use chrome sockets on impact wrenches



**TORQUE DRIVE**

# 1/2" DR SOCKET SETS



**13 PC Metric - 6 Point**

**601312** / SS1213M-6

STANDARD LENGTH METRIC

10, 12, 13, 14, 15, 16, 17, 18, 19, 20, 21, 22, 24mm

- Includes socket rail

**6** CrV



**14 PC Metric - 12 Point**

**601319** / SS1214M-12

STANDARD LENGTH METRIC

10, 11, 12, 13, 14, 15, 16, 17, 18, 19, 20, 21, 22, 24mm

- Includes socket rail

**12** CrV



**13 PC Deep Metric - 6 Point**

**601314** / SS1213DM-6

DEEP LENGTH METRIC

10, 12, 13, 14, 15, 16, 17, 18, 19, 20, 21, 22, 24mm

- Includes socket rail

**6** CrV



**14 PC Deep Metric - 12 Point**

**601320** / SS1214DM-12

DEEP LENGTH METRIC

10, 11, 12, 13, 14, 15, 16, 17, 18, 19, 20, 21, 22, 24mm

- Includes socket rail

**12** CrV

**⚠ WARNING:** Do not use chrome sockets on impact wrenches

## 3/4" DR SOCKET SETS

### ▼ Hand Tools shown in this section feature:

- All components forged from high quality Chrome Vanadium steel
- TORQUE DRIVE® sockets contact the fastener on the sides rather than the corners, reducing corner rounding and allowing 20% more torque
- Chamfered edges allow easiest socket placement on fastener, increasing productivity and reducing frustration
- Extra long deep sockets ensure maximum accessibility
- Meets or exceeds U.S. Federal Specs: GGG-W-641E and Canadian Government Specs: CDA39-GP-12b and ANSI specifications

### 17 PC S.A.E. - 12 Point

601405 / SS3417

#### STANDARD LENGTH S.A.E.

7/8, 15/16, 1, 1-1/16, 1-1/8, 1-3/16, 1-1/4, 1-5/16, 1-3/8, 1-7/16, 1-1/2, 1-5/8, 1-3/4, 1-13/16, 1-7/8, 2"

- Metal case



### 17 PC Deep S.A.E. - 6 Point

601407 / SS3417D-6

#### DEEP LENGTH S.A.E.

7/8, 15/16, 1, 1-1/16, 1-1/8, 1-3/16, 1-1/4, 1-5/16, 1-3/8, 1-7/16, 1-1/2, 1-5/8, 1-3/4, 1-13/16, 1-7/8, 2"

- Metal case



### 17 PC Metric - 12 Point

601406 / SS3417M

#### STANDARD LENGTH METRIC

19, 21, 22, 23, 24, 26, 27, 29, 30, 32, 35, 36, 38, 41, 46, 50mm

- Metal case



## TORQUE DRIVE®





## HEX BIT SOCKET SETS

▼ *Hand Tools shown in this section feature:*

- All sockets forged from high quality Chrome Vanadium steel
- Hex bits are made of superior quality S2 steel for maximum strength
- Meets or exceeds U.S. Federal Specs: GGG-W-641E and Canadian Government Specs: CDA39-GP-12b and ANSI B107-10M, B107-1, B107-5



### 7 PC S.A.E Hex Bit

601201 / HSW3811

- 3/8" DR  
2" (OVERALL LENGTH) S.A.E. HEX BIT SOCKETS:  
**1/8, 5/32, 3/16, 7/32, 1/4, 5/16, 3/8"**
- Includes socket rail



### 7 PC Metric Hex Bit

601202 / HSW3811M

- 3/8" DR  
2" (OVERALL LENGTH) METRIC HEX BIT SOCKETS:  
**3, 4, 5, 6, 7, 8, 10mm**
- Includes socket rail



### 10 PC S.A.E. Hex Bit

601802 / HSW3812-10

- 3/8" DR  
2" (OVERALL LENGTH) S.A.E. HEX BIT SOCKETS:  
**1/8, 5/32, 3/16, 7/32, 1/4, 5/16, 3/8"**
- 1/2" DR  
2-1/4" (OVERALL LENGTH) S.A.E. HEX BIT SOCKETS:  
**1/2, 9/16, 5/8"**
- Includes socket rail



### 10 PC Metric Hex Bit

601803 / HSW3812-10M

- 3/8" DR  
2" (OVERALL LENGTH) METRIC HEX BIT SOCKETS:  
**3, 4, 5, 6, 7, 8, 10mm**
- 1/2" DR  
2-1/4" (OVERALL LENGTH) METRIC HEX BIT SOCKETS:  
**12, 14, 16mm**
- Includes socket rail



**⚠ WARNING:** Do not use chrome sockets on impact wrenches



## 7 PC S.A.E. Long Ball Nose

601804 / LHSW3807

- 3/8" DR  
4" (OVERALL LENGTH) METRIC EXTRA LONG BALL NOSE HEX BIT SOCKETS:  
**1/8, 5/32, 3/16, 7/32, 1/4, 5/16, 3/8"**
- Includes socket rail



## 7 PC Metric Long Ball Nose

601805 / LHSW3807M

- 3/8" DR  
4" (OVERALL LENGTH) METRIC HEX BIT SOCKETS:  
**4, 5, 6, 7, 8, 9, 10mm**
- Includes socket rail



## 14 Piece S.A.E. / Metric – Long Series

601808 / LHSW1438-14C

- 4" (OVERALL LENGTH) S.A.E. EXTRA LONG HEX BIT SOCKETS:
- 1/4" DR:  
**1/8, 5/32, 3/16"**
- 3/8" DR:  
**7/32, 1/4, 5/16, 3/8"**
- 4" (OVERALL LENGTH) METRIC EXTRA LONG HEX BIT SOCKETS:
- 1/4" DR:  
**4, 5, 6mm**
- 3/8" DR:  
**7, 8, 9, 10mm**
- Blow mould case



**WARNING:** Do not use chrome sockets on impact wrenches



## TORX® BITS SOCKET SETS

▼ *Hand Tools shown in this section feature:*

- All sockets forged from high quality Chrome Vanadium steel
- TORX® bits are made of superior quality S2 steel for maximum strength
- Meets or exceeds U.S. Federal Specs: GGG-W-641E and Canadian Government Specs: CDA39-GP-12b and ANSI specifications
- TORX® is a registered trademark of Acument Intellectual Properties, LLC.



### 6 PC 3/8" DR - Tamperproof

601216 / SS386TB

2" (OVERALL LENGTH) TORX® BIT SOCKETS:  
T25, T30, T40, T45, T50, T55

- Includes socket rail



### 10 PC 1/4" & 3/8" DR - Tamperproof

601801 / SS1438-10TB

- 1/4" DR  
1-1/2" (OVERALL LENGTH) TORX® BIT  
T10, T15, T20, T25, T27, T30

- 3/8" DR  
2" (OVERALL LENGTH) TORX® BIT  
T40, T45, T50, T55

- Includes socket rail



### 11 PC 1/4" & 3/8" DR - Non-Tamperproof

601806 / SS1438-11T

- 1/4" DR  
1-1/2" (OVERALL LENGTH) TORX® BIT:  
T10, T15, T20, T25, T27, T30
- 3/8" DR 2" (OVERALL LENGTH) TORX® BIT:  
T40, T45, T47, T50, T55

- Includes socket rail



**WARNING:** Do not use chrome sockets on impact wrenches

# EXTERNAL TORX® SOCKET SETS



▼ *Hand Tools shown in this section feature:*

- All components forged from high quality Chrome Vanadium steel
- Chamfered edges
- TORX® is a registered trademark of Acument Intellectual Properties, LLC.

## 7 PC 1/4" DR

601111 / SS1407TS

STANDARD LENGTH EXTERNAL TORX®

**E4, E5, E6, E7, E8, E10, E11**

- Includes socket rail



## 6 PC 3/8" DR

601231 / SS3806TS

STANDARD LENGTH EXTERNAL TORX®

**E6, E8, E10, E12, E14, E16**

- Includes socket rail



## 12 PC 3/8" DR

601232 / SS3812TS

STANDARD LENGTH EXTERNAL TORX®

**E4, E5, E6, E7, E8, E10, E11, E12, E14, E16, E18, E20**

- Includes socket rail



## 9 PC 1/2" DR

601321 / SS1209TS

STANDARD LENGTH EXTERNAL TORX®

**E10, E11, E12, E14, E16, E18, E20, E22, E24**

- Includes socket rail



## 28 PC 1/4", 3/8" and 1/2" DR

601811 / SS328TS

STANDARD LENGTH EXTERNAL TORX®

- 1/4" DR: **E4, E5, E6, E7, E8, E10, E11**
- 3/8" DR: **E4, E5, E6, E7, E8, E10, E11, E12, E14, E16, E18, E20**
- 1/2" DR: **E10, E11, E12, E14, E16, E18, E20, E22, E24**
- Blow mould case



**WARNING:** Do not use chrome sockets on impact wrenches



# S.A.E. OPEN STOCK

- All items meet U.S. Federal Specifications: GGG-W-641e, Canadian Government Specification CDA39-GP-12b and ANSI specifications

Drive Size S.A.E.	1/4"		1/4"		3/8"		3/8"	
	Regular 6 pt.	Deep 6 pt.	Regular 12 pt.	Deep 12 pt.	Regular 6 pt.	Deep 6 pt.	Regular 12 pt.	Deep 12 pt.
3/16"	670106	670306	670206	670406				
7/32"	670107	670307	670207	670407				
1/4"	670108	670308	670208	670408	671108		671208	671408
9/32"	670109	670309	670209	670409				
5/16"	670110	670310	670210	670410	671110		671210	671410
11/32"	670111	670311	670211	670411				
3/8"	670112	670312	670212	670412	671112	671312	671212	671412
7/16"	670114	670314	670214	670414	671114	671314	671214	671414
1/2"	670116	670316	670216	670416	671116	671316	671216	671416
9/16"					671118	671318	671218	671418
5/8"					671120	671320	671220	671420
11/16"					671122	671322	671222	671422
3/4"					671124	671324	671224	671424
13/16"					671126	671326		
7/8"					671128	671328		
15/16"					671130			
1"					671132			

## 3/8" DR SPARK PLUG SOCKETS



Swivel style sockets

### 5 PC Magnetic Spark Plug Socket Set

**H3704**

- Long reach magnetic swivel spark plug socket set
- For hex sizes 5/8", 13/16" and the new 9/16" on Ford Triton® engines
- Made from CrV steel, with a bright hard chrome finish

**Set Includes:**

- 3/8" DR x 9/16" HEX x 2-1/2" (66mm) Long ..... **H3704-10**
- 3/8" DR x 5/8" HEX x 4" (101.6mm) Long ..... **H3704-14**
- 3/8" DR x 5/8" HEX x 6" (152.4mm) Long ..... **H3704-16**
- 3/8" DR x 5/8" HEX x 11" (279.4mm) Long ..... **H3704-18**
- 3/8" DR x 13/16" HEX x 6" (152.4mm) Long ..... **H3704-22**



### Spark Plug Sockets

- Features rubber inserts to protect spark plugs from damage



PROD. NO.

Drive

Hex Size

**671932**

3/8"

5/8"

**671934**

3/8"

13/16"



**WARNING:** Do not use chrome sockets on impact wrenches

**SPARK PLUG SOCKETS**  
See page 295 in the Specialty Auto section for similar products

# S.A.E. OPEN STOCK



- All items meet U.S. Federal Specifications: GGG-W-641e, Canadian Government Specification CDA39-GP-12b and ANSI specifications

Drive Size S.A.E.	1/2"		1/2"		3/4"		1"	
	Regular 6 pt.	Deep 6 pt.	Regular 12 pt.	Deep 12 pt.	Regular 12pt.	Deep 6 pt.	Regular 12 pt.	
3/8"	672112		672212					
7/16"	672114	672314	672214	672414				
1/2"	672116	672316	672216	672416				
9/16"	672118	672318	672218	672418				
5/8"	672120	672320	672220	672420				
11/16"	672122	672322	672222	672422				
3/4"	672124	672324	672224	672424	673212			
13/16"	672126	672326	672226	672426				
7/8"	672128	672328	672228	672428	673214	673414		
15/16"	672130	672330	672230	672430	673215	673415		
1"	672132	672332	672232	672432	673216	673416		
1-1/16"	672134	672334	672234	672434	673217	673417		
1-1/8"	672136	672336	672236	672436	673218	673418		
1-3/16"	672138	672238		673219		673419		
1-1/4"	672140	672340	672240	672440	673220	673420		
1-5/16"					673221	673421		
1-3/8"					673222	673422		
1-7/16"					673223	673423	674223	
1-1/2"					673224	673424	674224	
1-9/16"					673225			
1-5/8"					673226	673426	674226	
1-11/16"					673227	674227		
1-3/4"					673228	673428	674228	
1-13/16"					673229	673429	674229	
1-7/8"					673230	673430	674230	
2"					673232	673432	674232	
2-1/8"					674234			
2-3/16"					674235			
2-1/4"					674236			
2-3/8"					674238			
2-1/2"					674240			
2-5/8"					674242			
2-3/4"					674244			
2-15/16"					674247			
3"					674248			
3-1/8"					674250			



672414



672228



673224

**WARNING:** Do not use chrome sockets on impact wrenches



# METRIC OPEN STOCK

- All items meet U.S. Federal Specifications: GGG-W-641e, Canadian Government Specification CDA39-GP-12b and ANSI specifications

Drive	1/4"	1/4"	1/4"	1/4"	3/8"	3/8"	3/8"	3/8"
Size Metric	Regular 6 pt.	Deep 6 pt.	Regular 12 pt.	Deep 12 pt.	Regular 6 pt.	Deep 6 pt.	Regular 12 pt.	Deep 12pt.
4mm	670502	670702	670602	670802				
4.5mm	670503							
5mm	670504	670704	670604	670804				
5.5mm	670505	670705						
6mm	670506	670706	670606	670806	671506			
7mm	670507	670707	670607	670807	671507			
8mm	670508	670708	670608	670808	671508	671708	671608	671808
9mm	670509	670709	670609	670809	671509	671709	671609	671809
10mm	670510	670710	670610	670810	671510	671710	671610	671810
11mm	670511	670711	670611	670811	671511	671711	671611	671811
12mm	670512	670712	670612	670812	671512	671712	671612	671812
13mm	670513	670713			671513	671713	671613	671813
14mm					671514	671714	671614	671814
15mm					671515	671715	671615	671815
16mm					671516	671716	671616	671816
17mm					671517	671717	671617	671817
18mm					671518	671718	671618	671818
19mm					671519	671719	671619	671819
20mm					671520			
21mm					671521	671721		
22mm					671522			
23mm								
24mm					671524			

**⚠ WARNING:** Do not use chrome sockets on impact wrenches



# METRIC OPEN STOCK



- All items meet U.S. Federal Specifications: GGG-W-641e, Canadian Government Specification CDA39-GP-12b and ANSI specifications

Drive Size Metric	1/2"		1/2"		3/4"
	Regular 6 pt.	Deep 6 pt.	Regular 12 pt.	Deep 12 pt.	Regular 12 pt.
8mm	672508				
9mm	672509				
10mm	672510	672710	672610	672810	
11mm	672511		672611	672811	
12mm	672512	672712	672612	672812	
13mm	672513	672713	672613	672813	
14mm	672514	672714	672614	672814	
15mm	672515	672715	672615	672815	
16mm	672516	672716	672616	672816	
17mm	672517	672717	672617	672817	
18mm	672518	672718	672618	672818	
19mm	672519	672719	672619	672819	673619
20mm	672520	672720	672620	672820	
21mm	672521	672721	672621	672821	673621
22mm	672522	672722	672622	672822	673622
23mm	672523	672723			673623
24mm	672524	672724	672624	672824	673624
26mm					673626
27mm	672527	672727			673627
29mm					673629
30mm	672530				673630
32mm	672532				673632
35mm					673635
36mm					673636
38mm					673638
41mm					673641
46mm					673646
50mm					673650



672824



672610

**WARNING:** Do not use chrome sockets on impact wrenches

## JET-A-SIZER - Fastener Sizing Tool

779901 / JFST-1

- Handy tool quickly and accurately identifies size of nut or bolt head
- Works on 6 point S.A.E. and Metric fasteners
- Eliminates unnecessary trips to the tool box
- Permanently stamped sizes for a lifetime of use
- Integrated keychain hook keeps tool handy
- Measuring range: 5/16 - 1", 8 - 25mm



779901



## S.A.E. HEX BITS OPEN STOCK

▼ Hand Tools shown in this section feature:

- All sockets forged from high quality Chrome Vanadium steel
- Hex bits are made of superior quality S2 steel for maximum strength
- Meets or exceeds U.S. Federal Specs: GGG-W-641E and Canadian Government Specs: CDA39-GP-12b and ANSI specifications



LONG  
677130



REGULAR  
677210

Drive	1/4"	3/8"	3/8"	3/8"	1/2"
Size S.A.E.	4" Long	Regular	4" Long	4" Long Ball Nose	Regular
1/8"	677021	677204		677224	
5/32"	677022	677205		677225	
3/16"	677023	677206		677226	
7/32"		677207	677127	677227	
1/4"		677208	677128	677228	
9/32"					
5/16"		677210	677130	677230	
11/32"					
3/8"		677212	677132	677232	
1/2"					677316
9/16"					677318
5/8"					677320

**Note:** 3/8" drive regular length sockets = 2" overall length  
1/2" drive regular length sockets = 2-1/4" overall length



**WARNING:** Do not use chrome sockets on impact wrenches



LONG BALL NOSE



# METRIC HEX BITS OPEN STOCK



▼ Hand Tools shown in this section feature:

- All sockets forged from high quality Chrome Vanadium steel
- Hex bits are made of superior quality S2 steel for maximum strength
- Meets or exceeds U.S. Federal Specs: GGG-W-641E and Canadian Government Specs: CDA39-GP-12b and ANSI specifications

Drive	1/4"	3/8"	3/8"	3/8"	1/2"
Size Metric	4" Long	Regular	4" Long	4" Long Ball Nose	Regular
3mm		677253			
4mm	677071	677254		677274	
5mm	677072	677255		677275	
6mm	677073	677256		677276	
7mm		677257	677177	677277	
8mm		677258	677178	677278	
9mm			677179	677279	
10mm		677260	677180	677280	
12mm					677362
14mm					677364
16mm					677366

**Note:** 3/8" drive regular length sockets = 2" overall length  
 1/2" drive regular length sockets = 2-1/4" overall length



**WARNING:** Do not use chrome sockets on impact wrenches



LONG  
677179



LONG BALL NOSE  
677280



REGULAR  
677366



## TORX® BITS OPEN STOCK



677767  
TAMPERPROOF

677787  
NON-TAMPERPROOF

Drive Size TORX®	1/4"	1/4"	3/8"	3/8"
	Non-Tamperproof	Tamperproof	Non-Tamperproof	Tamperproof
T10	677726	677706		
T15	677727	677707		
T20	677728	677708		
T25	677729	677709		677759
T27	677730	677710		
T30	677731	677711		677761
T40			677783	677763
T45			677784	677764
T47			677785	
T50			677786	677766
T55			677787	677767



## EXTERNAL TORX® OPEN STOCK



677865

Drive Size External TORX®	1/4"	3/8"	1/2"
	Regular	Regular	Regular
E4	677803	677821	
E5	677804	677822	
E6	677805	677823	
E7	677806	677845	
E8	677807	677824	
E10	677809	677825	677851
E11	677810	677847	677852
E12		677826	677853
E14		677827	677855
E16		677828	677857
E18		677830	677859
E20		677832	677861
E22			677863
E24			677865



**!** WARNING: Do not use chrome sockets on impact wrenches

# SOCKET ACCESSORIES



▼ *Hand Tools shown in this section feature:*

- All components are forged from high quality Chrome Vanadium steel
- Meets or exceeds U.S. Federal Specs: GGG-W-641E and Canadian Government Specs: CDA39-GP-12b and ANSI specifications

## Universal Joints

PROD. NO.	MOD. NO.	Drive
<b>670908</b>	SA1407	1/4" x 1/4"
<b>671910</b>	SA3810	3/8" x 3/8"
<b>672908</b>	SA1207	1/2" x 1/2"



670908

## Socket Adaptors

PROD. NO.	MOD. NO.	Male	Female
<b>OPEN STOCK</b>			
<b>670911</b>	SA1410	3/8"	1/4"
<b>671913</b>	SA3813	1/4"	3/8"
<b>671914</b>	SA3814	1/2"	3/8"
<b>672911</b>	SA1210	3/8"	1/2"
<b>672912</b>	SA1211	3/4"	1/2"
<b>673907</b>	SA7506	1/2"	3/4"
<b>673912</b>	SA7511	1"	3/4"

### 5 PC CHROME SOCKET ADAPTOR SET

<b>690115</b>	SA-5S	3/8"	1/4"
		1/4"	3/8"
		1/2"	3/8"
		3/8"	1/2"
		3/4"	1/2"



673912



672911



673907

## Socket Clip Rails

- Includes one each for 1/4", 3/8", and 1/2" drive sockets

PROD. NO.	MOD. NO.	Drive	Clips
<b>3 PC SOCKET CLIP RAIL SET</b>			
<b>690111</b>	SCH-3S	1/4, 3/8, 1/2"	16 each (48 Total)

### OPEN STOCK

<b>670913</b>	SCH-14	1/4"	16
<b>671917</b>	SCH-38	3/8"	16
<b>672913</b>	SCH-12	1/2"	16



690115



690111

**WARNING:** Do not use chrome sockets on impact wrenches



## SOCKET ACCESSORIES

▼ Hand Tools shown in this section feature:

- All components are forged from high quality Chrome Vanadium steel
- Meets or exceeds U.S. Federal Specs: GGG-W-641E and Canadian Government Specs: CDA39-GP-12b and ANSI specifications

### Flex Bars

PROD. NO.	MOD. NO.	Drive	Length	Max. Torque
<b>670902</b>	SA1401	1/4"	6"	35 ft/lbs
<b>671902</b>	SA3801	3/8"	8"	100 ft/lbs
<b>672902</b>	SA1201	1/2"	10"	330 ft/lbs
<b>672903</b>	SA1202	1/2"	15"	330 ft/lbs
<b>672918</b>	SA1213	1/2" *	24"	330 ft/lbs
<b>673909</b>	SA7508	3/4" *	24"	750 ft/lbs
<b>673911</b>	SA7510	3/4" **	–	750 ft/lbs
<b>674909</b>	SA1008	1"	26"	1,850 ft/lbs

Replacement repair kits listed in the back of the catalogue

- \***672918** and **673909** features heavy duty head design
- \*\***673911** comes with head only – requires drive handle



### Ratcheting Breaker Bars

- Swivel head breaker bar with 24 tooth ratchet action
- Use in neutral position to break fasteners free, then employ ratchet for fast removal of fastener
- Can also be used to apply greater torque than is possible with standard 1/2" drive ratchets
- Chrome Molybdenum and Chrome Vanadium construction for professional use
- Repair kit available (**900289**)

PROD. NO.	MOD. NO.	Drive	Length
<b>672932</b>	JRBB-18	1/2"	18"
<b>672933</b>	JRBB-24	1/2"	24"



Extra strong CrMo gear components for professional use



**WARNING:** Do not use chrome sockets on impact wrenches

## Speeder Handles

PROD. NO.	MOD. NO.	Drive	Length
<b>671911</b>	SA3811	3/8"	16"
<b>672909</b>	SA1208	1/2"	16-1/2"

**CrV**

## Sliding T-Handles

PROD. NO.	MOD. NO.	Drive	Length
<b>670907</b>	SA1406	1/4"	4-1/4"
<b>671909</b>	SA3809	3/8"	8"
<b>672907</b>	SA1206	1/2"	10"
<b>673906</b>	SA7505	3/4"	18"
<b>673910</b>	SA7509	3/4" *	Head Only
<b>674904</b>	SA1003	1"	22"

\*Requires drive handle (sold separately)



## Spinner Handles

PROD. NO.	MOD. NO.	Drive	Length
<b>670912</b>	SA1411	1/4"	6"



## T-Handle Spinner Wrenches

- Unique aluminum grip with bearings provides super smooth spinner action
- Adjustable grip can be used in 4 depth positions or removed for access to recessed areas
- Pull down locking collar keeps grip at desired location for most stable use
- 12" length reaches deep into engine bays and other confined spaces
- Chrome Vanadium steel for professional use
- Textured PVC coated T-handle for improved user comfort

## 3 PC T-Handle Spinner Wrench Set

PROD. NO.	MOD. NO.	Drive	Length	Pieces
<b>690130</b>	JSTH-3S	1/4, 3/8, 1/2"	12"	3

- Comes in convenient EVA foam tool box organizer

## Open Stock

<b>670930</b>	—	1/4"	12"	1
<b>671930</b>	—	3/8"	12"	1
<b>672930</b>	—	1/2"	12"	1



**WARNING:** Do not use chrome sockets on impact wrenches



## SOCKET ACCESSORIES

▼ Hand Tools shown in this section feature:

- All components are forged from high quality Chrome Vanadium steel
- Meets or exceeds U.S. Federal Specs: GGG-W-641E and Canadian Government Specs: CDA39-GP-12b and ANSI specifications

### Extension Bars



690120



690121



672914

PROD. NO.	MOD. NO.	Pieces	Drive	Length
<b>SETS</b>				
690120	SE38-4S	4	3/8"	1-3/4, 3, 6, 10"
690121	SE12-3S	3	1/2"	2, 5, 10"
672914*	SE12-4S	4	1/2"	15, 18, 24, 30" (extra long)

\* Not CrV Steel

### OPEN STOCK

670904	SA1403	—	1/4"	2"
670905	SA1404	—	1/4"	3"
670915	SA1412	—	1/4"	4"
670906	SA1405	—	1/4"	6"
671904	SA1403	—	3/8"	1-3/4"
671905	SA3804	—	3/8"	3"
671907	SA3806	—	3/8"	6"
671908	SA3808	—	3/8"	10"
672904	SA1203	—	1/2"	2"
672905	SA1204	—	1/2"	5"
672906	SA1205	—	1/2"	10"
673903	SA7502	—	3/4"	4"
673904	SA7503	—	3/4"	8"
673905	SA7504	—	3/4"	16"
674903	SA1002	—	1"	16"
674905	SA1004	—	1"	8"



**WARNING:** Do not use chrome sockets on impact wrenches

## Locking Extension Bars

- Sockets and accessories lock on and cannot be removed until lock ring is retracted
- Keeps everything from ratchet to the socket positively connected, preventing lost pieces
- Especially useful when multiple extensions must be used
- Ideal for use with JETs quick release ratchet handles
- Coloured lock rings help identify drive size - a JET exclusive!
- Highest quality Chrome Vanadium steel for professional use

PROD. NO.	MOD. NO.	Pieces	Drive	Length
<b>SETS</b>				
690124	SE38-3SL	3	3/8"	3, 6, 10"
690125	SE12-3SL	3	1/2"	3, 5, 10"
<b>OPEN STOCK</b>				
671947	SA3804L	—	3/8"	3"
671948	SA3806L	—	3/8"	6"
671949	SA3808L	—	3/8"	10"
672947	SA1203L	—	1/2"	3"
672948	SA1204L	—	1/2"	5"
672949	SA1205L	—	1/2"	10"



**WARNING:** Do not use chrome sockets on impact wrenches



690124



690125



# SOCKET ACCESSORIES



690122



690123

## 2 Way Wobble Extension Bars

- Two position extensions provide regular or wobble drive
- Place socket in first position for wobble drive; allows improved access to hard-to-reach areas
- Push socket down to second position to lock it solidly in place; allows maximum torque
- Each extension replaces two others but doesn't cost twice as much
- Highest quality Chrome Vanadium steel for professional use

PROD. NO.	MOD. NO.	Pieces	Drive	Length
<b>SETS</b>				
690122	SE38-4SW	4	3/8"	1-3/4, 3, 6, 10"
690123	SE12-3SW	3	1/2"	2, 5, 10"

## OPEN STOCK

671951	SA3803W	—	3/8"	1-3/4"
671952	SA3804W	—	3/8"	3"
671953	SA3806W	—	3/8"	6"
671954	SA3808W	—	3/8"	10"
672951	SA1203W	—	1/2"	2"
672952	SA1204W	—	1/2"	5"
672953	SA1205W	—	1/2"	10"

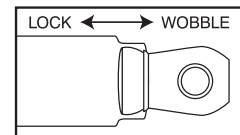

**WARNING:** Do not use chrome sockets on impact wrenches





# Impact Sockets

3/8" TO 1" DRIVE  
UNIVERSAL SOCKETS  
MAG WHEEL SOCKETS  
TORQUE LIMITING STICKS  
HEX & TORX® BITS SOCKETS  
TRUCK TIRE SOCKETS  
ACCESSORIES



## TORQUE DRIVE®



## 3/8" DRIVE SOCKET SETS

### ▼ Hand Tools shown in this section feature:

- Sockets made of the finest quality S.A.E. 4140 Chrome Molybdenum high impact steel
- TORQUE DRIVE® socket design contacts the fastener on the sides instead of the corners, reducing fastener rounding and allowing up to 20% more torque
- Chamfered edges allow easiest socket placement on fastener, increasing productivity and reducing frustration
- Extra long deep sockets ensure maximum accessibility
- Meets or exceeds U.S. Federal Specs: GGG-W-660A and ANSI specifications

### 8 PC S.A.E. - 6 Point

610201 / PS838

#### STANDARD LENGTH S.A.E.

5/16, 3/8, 7/16, 1/2, 9/16, 5/8, 11/16, 3/4"

- Blow mould case



### 8 PC Deep S.A.E. - 6 Point

610203 / PS838D

#### DEEP LENGTH S.A.E.

5/16, 3/8, 7/16, 1/2, 9/16, 5/8, 11/16, 3/4"

- Blow mould case



### 12 PC S.A.E. - 6 Point

610207 / PS1238

#### STANDARD LENGTH S.A.E.

5/16, 3/8, 7/16, 1/2, 9/16, 5/8, 11/16, 3/4, 13/16, 7/8, 15/16, 1"

- Blow mould case



### 12 PC Deep S.A.E.- 6 Point

610208 / PS1238D

#### DEEP LENGTH S.A.E.

5/16, 3/8, 7/16, 1/2, 9/16, 5/8, 11/16, 3/4, 13/16, 7/8, 15/16, 1"

- Blow mould case



### 13 PC Metric - 6 Point

610217 / PS1438M

#### STANDARD LENGTH METRIC

7, 8, 9, 10, 11, 12, 13, 14, 15, 16, 17, 18, 19mm

- Blow mould case



### 13 PC Deep Metric - 6 Point

610218 / PS1338DM

#### DEEP LENGTH METRIC

7, 8, 9, 10, 11, 12, 13, 14, 15, 16, 17, 18, 19mm

- Blow mould case



# 1/2" DRIVE SOCKET SETS



▼ Hand Tools shown in this section feature:

- Sockets made of the finest quality S.A.E. 4140 Chrome Molybdenum high impact steel
- TORQUE DRIVE® socket design contacts the fastener on the sides instead of the corners, reducing fastener rounding and allowing up to 20% more torque
- Chamfered edges allow easiest socket placement on fastener, increasing productivity and reducing frustration
- Extra long deep sockets ensure maximum accessibility
- Meets or exceeds U.S. Federal Specs: GGG-W-660A and ANSI specifications

**TORQUE DRIVE**®



**10 PC S.A.E. - 6 Point**

**610302** / PS1012

STANDARD LENGTH S.A.E.

7/16, 1/2, 9/16, 5/8, 11/16, 3/4, 13/16, 7/8, 15/16, 1"

- Blow mould case



**10 PC Deep S.A.E. - 6 Point**

**610303** / PS1012D

DEEP LENGTH S.A.E.

7/16, 1/2, 9/16, 5/8, 11/16, 3/4, 13/16, 7/8, 15/16, 1"

- Blow mould case with removable lid



**13 PC S.A.E. - 6 Point**

**610321** / PS1312

STANDARD LENGTH S.A.E.

7/16, 1/2, 9/16, 5/8, 11/16, 3/4, 13/16, 7/8, 15/16, 1, 1-1/16, 1-1/8, 1-1/4"

- Blow mould case



**13 PC Deep S.A.E. - 6 Point**

**610323** / PS1312D

DEEP LENGTH S.A.E.

7/16, 1/2, 9/16, 5/8, 11/16, 3/4, 13/16, 7/8, 15/16, 1, 1-1/16, 1-1/8, 1-1/4"

- Blow mould case



**19 PC S.A.E. - 6 Point**

**610328** / PS1912

STANDARD LENGTH S.A.E.

3/8, 7/16, 1/2, 9/16, 5/8, 11/16, 3/4, 13/16, 7/8, 15/16, 1, 1-1/16, 1-1/8, 1-3/16, 1-1/4, 1-5/16, 1-3/8, 1-7/16, 1-1/2"

- Blow mould case with removable lid



**19 PC Deep S.A.E. - 6 Point**

**610329** / PS1912D

DEEP LENGTH S.A.E.

3/8, 7/16, 1/2, 9/16, 5/8, 11/16, 3/4, 13/16, 7/8, 15/16, 1, 1-1/16, 1-1/8, 1-3/16, 1-1/4, 1-5/16, 1-3/8, 1-7/16, 1-1/2"

- Blow mould case with removable lid



**TORQUE DRIVE****1/2" DRIVE SOCKET SETS**

Jumbo Sizes

**8 PC Jumbo S.A.E. - 6 Point****610314** / PS812*STANDARD LENGTH S.A.E.***1-9/16, 1-5/8, 1-11/16, 1-3/4, 1-13/16, 1-7/8, 1-15/16, 2"**

- Blow mould case



Jumbo Sizes

**8 PC Jumbo Deep S.A.E. - 6 Point****610315** / PS812D*DEEP LENGTH S.A.E.***1-9/16, 1-5/8, 1-11/16, 1-3/4, 1-13/16, 1-7/8, 1-15/16, 2"**

- Blow mould case with removable lid

**12 PC Metric - 6 Point****610308** / PS1212M*STANDARD LENGTH METRIC***10, 12, 13, 14, 15, 16, 17, 18, 19, 21, 22, 24mm**

- Blow mould case

**12 PC Deep Metric - 6 Point****610310** / PS1212DM*DEEP LENGTH METRIC***10, 12, 13, 14, 15, 16, 17, 18, 19, 21, 22, 24mm**

- Blow mould case



## TORQUE DRIVE

**22 PC Metric - 6 Point** **610338** / PS2212M

STANDARD LENGTH METRIC

10, 11, 12, 13, 14, 15, 16, 17, 18, 19, 20, 21, 22, 23, 24, 25, 26, 27, 28, 29, 30, 32mm

- Blow mould case with removable lid



**22 PC Deep Metric - 6 Point** **610339** / PS2212DM

DEEP LENGTH METRIC

10, 11, 12, 13, 14, 15, 16, 17, 18, 19, 20, 21, 22, 23, 24, 25, 26, 27, 28, 29, 30, 32mm

- Blow mould case with removable lid



**12 PC Jumbo Metric - 6 Point** **610334** / PS1212LM

STANDARD LENGTH METRIC

23, 24, 25, 26, 27, 28, 30, 32, 33, 34, 35, 36mm

- Blow mould case



Jumbo Sizes

**12 PC Jumbo Deep Metric - 6 Point** **610335** / PS122DLM

DEEP LENGTH METRIC

23, 24, 25, 26, 27, 28, 30, 32, 33, 34, 35, 36mm

- Blow mould case with removable lid



Jumbo Sizes

**27 PC Deep S.A.E./Metric - 6 Point** **610327** / PS2712DC

DEEP LENGTH S.A.E.

7/16, 1/2, 9/16, 5/8, 11/16, 3/4, 13/16, 7/8, 15/16, 1, 1-1/16, 1-1/8, 1-1/4"

DEEP LENGTH METRIC

10, 12, 13, 14, 15, 16, 17, 18, 19, 21, 22, 24mm

STANDARD ACCESSORIES:

- 5" extension and 1" universal joint
- Blow mould case with removable lid



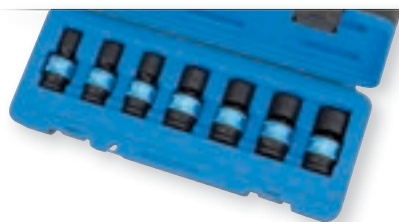

610341

## 1/2" DRIVE UNIVERSAL SOCKET SETS

▼ Hand Tools shown in this section feature:

- Made from the best quality S.A.E. 4140 Chrome Molybdenum high impact steel
- Heavy duty flexible joints allow easier access to fasteners in hard to reach areas
- Reinforcement ring ensures maximum strength

### 7 PC S.A.E. Universal - 6 Point

610382 / PSU712

STANDARD LENGTH S.A.E.

1/2, 9/16, 5/8, 11/16, 3/4, 13/16, 7/8"

- Blow mould case



### 9 PC Metric Universal - 6 Point

610388 / PSU912M

STANDARD LENGTH METRIC

13, 14, 15, 16, 17, 18, 19, 21, 22mm

- Blow mould case



## MAG WHEEL SOCKETS

▼ Hand Tools shown in this section feature:

- Specially designed for use on high end aluminum and chrome plated wheels
- Premium grade Chrome Molybdenum Steel for professional use
- Plastic sleeve and inner cap to prevent scratches

### 1/2" DR Deep S.A.E. / Metric Set

PROD. NO.	MOD. NO.	Drive	Pieces	Sizes
610341	MWPS-512	1/2"	5	13/16", 7/8", 17, 19 (3/4"), 21mm

- Blow mould case



### 1/2" DR Deep - Open Stock

PROD. NO.	Drive	Sizes	Replacement Sleeve	Replacement Insert
682867	1/2"	17mm	682981	682991
682869	1/2"	19mm	682982	682992
682871	1/2"	21mm	682983	682993
682876	1/2"	13/16"	682985	682995
682878	1/2"	7/8"	682986	682996

# TORQUE LIMITING EXTENSIONS



▼ *Hand Tools shown in this section feature:*

- Specially designed Chrome Molybdenum spring steel flexes at preset torque ratings
- Allows accurate application of specific torque to automobile wheel fasteners
- Prevents over-tightening or uneven tightening of lug nuts, a major cause of wheel and brake rotor damage
- 5 extensions cover most passenger and light truck / SUV wheels
- For use with 1/2" drive impact wrenches rated at 250 ft/lbs and line pressure of 90 – 110 PSI
- For aluminum and chrome wheels, use with JET's 1/2" drive Mag Wheel Power Sockets

## 5 PC 1/2" DR Set

PROD. NO.	MOD. NO.	Drive	Pieces	Torque (ft/lbs)
<b>682961</b>	JTLE-5S	1/2"	5	65, 80, 100, 120, 140

- Blow mould case with removable lid



## 1/2" DR - Open Stock

PROD. NO.	Drive	Torque (ft/lbs)	Length	Colour
<b>682964</b>	1/2"	65	7-3/4"	Yellow
<b>682965</b>	1/2"	80	7-3/4"	Blue
<b>682966</b>	1/2"	100	7-3/4"	Gray
<b>682967</b>	1/2"	120	7-3/4"	White
<b>682968</b>	1/2"	140	7-3/4"	Aqua

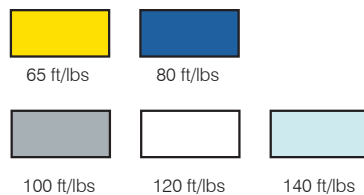

**TORQUE DRIVE**

**Jumbo Sizes**

## 3/4" DRIVE SOCKET SETS

▼ *Hand Tools shown in this section feature:*

- Sockets made of the finest quality S.A.E. 4140 Chrome Molybdenum high impact steel
- TORQUE DRIVE® socket design contacts the fastener on the sides instead of the corners, reducing fastener rounding and allowing up to 20% more torque
- Chamfered edges allow easiest socket placement on fastener, increasing productivity and reducing frustration
- Extra long deep sockets ensure maximum accessibility
- Most sets come with two-tone blow mould cases with removable lids for use as an organizer
- Meets or exceeds U.S. Federal Specs: GGG-W-660A and ANSI specifications

### 8 PC S.A.E. - 6 Point

**610401 / PS834**

*STANDARD LENGTH S.A.E.*

**1, 1-1/16, 1-1/8, 1-1/4, 1-5/16, 1-3/8, 1-7/16, 1-1/2"**

- Blow mould case



### 8 PC Deep S.A.E. - 6 Point

**610402 / PS834D**

*DEEP LENGTH S.A.E.*

**1, 1-1/16, 1-1/8, 1-1/4, 1-5/16, 1-3/8, 1-7/16, 1-1/2"**

- Blow mould case



### 8 PC Jumbo S.A.E. - 6 Point

**610404 / PS834L**

*STANDARD LENGTH S.A.E.*

**2-1/16, 2-1/8, 2-3/16, 2-1/4, 2-5/16, 2-3/8, 2-7/16, 2-1/2"**

- Includes all 8 sizes of 3/4" DR S.A.E. Jumbo Power Sockets from 2-1/16" to 2-1/2"
- Blow mould case with removable lid



### 14 PC Deep S.A.E. - 6 Point

**610406 / PS1434D**

*DEEP LENGTH S.A.E.*

**3/4, 13/16, 7/8, 15/16, 1, 1-1/16, 1-1/8, 1-3/16, 1-1/4, 1-5/16, 1-3/8, 1-7/16, 1-1/2, 1-5/8"**

- Blow mould case with removable lid



### 16 PC S.A.E. - 6 Point

**610403 / PS1634**

*STANDARD LENGTH S.A.E.*

**3/4, 13/16, 7/8, 15/16, 1, 1-1/16, 1-1/8, 1-1/4, 1-5/16, 1-3/8, 1-7/16, 1-1/2, 1-5/8, 1-3/4, 1-7/8, 2"**

- Blow mould case with removable lid





# 3/4" DRIVE SOCKET SETS



## 17 PC Metric - 6 Point

610407 / PS1734M

STANDARD LENGTH METRIC

19, 21, 22, 23, 24, 26, 27, 29, 30, 32, 33, 35, 36, 38, 41, 46, 50mm

- Blow mould case with removable lid



NEW

## 17 PC Deep Metric - 6 Point

610408 / PS1734DM

DEEP LENGTH METRIC

19, 21, 22, 23, 24, 26, 27, 29, 30, 32, 33, 35, 36, 38, 41, 46, 50mm

- Blow mould case with removable lid



NEW

## 21 PC S.A.E. - 6 Point

610409 / PS2134

STANDARD LENGTH S.A.E.

3/4, 13/16, 7/8, 15/16, 1, 1-1/16, 1-1/8, 1-3/16, 1-1/4, 1-5/16, 1-3/8, 1-7/16, 1-1/2, 1-9/16, 1-5/8, 1-11/16, 1-3/4, 1-13/16, 1-7/8, 1-15/16, 2"

- Includes all 21 sizes of 3/4" DR S.A.E. Power Sockets up to 2"!
- Blow mould case with removable lid



## 21 PC Deep S.A.E. - 6 Point

610410 / PS2134D

DEEP LENGTH S.A.E.

3/4, 13/16, 7/8, 15/16, 1, 1-1/16, 1-1/8, 1-3/16, 1-1/4, 1-5/16, 1-3/8, 1-7/16, 1-1/2, 1-9/16, 1-5/8, 1-11/16, 1-3/4, 1-13/16, 1-7/8, 1-15/16, 2"

- Includes all 21 sizes of 3/4" DR S.A.E. Deep Power Sockets up to 2"!
- Blow mould case with removable lid



# 1" DRIVE SOCKET SETS

## 9 PC S.A.E. - 6 Point

610501 / PS901

STANDARD LENGTH S.A.E.

1, 1-1/8, 1-1/4, 1-3/8, 1-1/2, 1-5/8, 1-3/4, 1-7/8, 2"

- Blow mould case with removable lid



**TORQUE DRIVE**



## 18 PC S.A.E. - 6 Point

610509 / PS1801

STANDARD LENGTH S.A.E.

3/4, 13/16, 7/8, 15/16, 1, 1-1/16, 1-1/8, 1-3/16, 1-1/4, 1-5/16, 1-3/8, 1-7/16, 1-1/2, 1-5/8, 1-3/4, 1-13/16, 1-7/8, 2"

- Blow mould case with removable lid



**TORQUE DRIVE**

## 1" DRIVE SOCKET SETS

▼ *Hand Tools shown in this section feature:*

- Sockets made of the finest quality S.A.E. 4140 Chrome Molybdenum high impact steel
- TORQUE DRIVE® socket design contacts the fastener on the sides instead of the corners, reducing fastener rounding and allowing up to 20% more torque
- Chamfered edges allow easiest socket placement on fastener, increasing productivity and reducing frustration
- Extra long deep sockets ensure maximum accessibility
- Most sets come with two-tone blow mould case with removable lid for use as an organizer
- Meets or exceeds U.S. Federal Specs: GGG-W-660A and ANSI specifications



### 9 PC Deep S.A.E. - 6 Point

**610503 / PS901D**

*DEEP LENGTH S.A.E.*

**1, 1-1/8, 1-1/4, 1-3/8, 1-1/2, 1-5/8, 1-3/4, 1-7/8, 2"**

- Blow mould case with removable lid



### 11 PC Jumbo Deep S.A.E. - 6 Point

**610504 / PS1101D**

*DEEP LENGTH S.A.E.*

**2-1/16, 2-1/8, 2-3/16, 2-1/4, 2-5/16, 2-3/8, 2-7/16, 2-1/2, 2-9/16, 2-5/8, 2-3/4"**

- Blow mould case with removable lid



Jumbo Sizes



### 12 PC Jumbo S.A.E. - 6 Point

**610506 / PS1201**

*STANDARD LENGTH S.A.E.*

**2-1/8, 2-1/4, 2-3/8, 2-1/2, 2-9/16, 2-5/8, 2-3/4, 2-7/8, 3, 3-1/8, 3-1/4, 3-1/2"**

- Blow mould case with removable lid



Jumbo Sizes



### 16 PC Deep S.A.E. - 6 Point

**610508 / PS1601D**

*DEEP LENGTH S.A.E.*

**7/8, 15/16, 1, 1-1/16, 1-1/8, 1-3/16, 1-1/4, 1-5/16, 1-3/8, 1-7/16, 1-1/2, 1-5/8, 1-3/4, 1-13/16, 1-7/8, 2"**

- Blow mould case with removable lid





610515

▼ *Hand Tools shown in this section feature:*

- Made of highest quality S.A.E. 4140 Chrome Molybdenum steel for maximum strength and durability
- Special sizes designed for use on most truck wheel fasteners

### 11 PC S.A.E./Metric

- 11 of the most popular S.A.E. and Metric sizes for heavy trucks
- 4 point sockets for inner Budd-style square fasteners
- Special 1-1/2" hex deep socket features controlled depth, preventing contact with inner cap nut
- Deep thin wall sockets designed for use on Dayton style lugnuts where space is limited
- Blow mould case with removable lid

PROD. NO.	MOD. NO.	4 Point Shallow Budd Sockets	6 Point Deep Budd Sockets	6 Point Thin Wall Sockets
<b>610515</b>	TTPS-11SM	17mm 21mm 13/16"	33mm, 35mm, 38mm, 41mm, 1-1/2" controlled depth	1-1/16" 1-1/8" -1/4"



## 1" DRIVE TRUCK TIRE - OPEN STOCK

### Budd Wheel Type - 4 Point

- Designed for use on inner budd-style square fasteners

PROD. NO.	Size	Length
<b>684921</b>	13/16"	57mm
<b>684922</b>	15/16"	57mm
<b>684971</b>	17mm	57mm
<b>684975</b>	21mm	57mm

### Budd Wheel Type - 6 Point

- For use on most import and some domestic trucks
- 1-1/2" hex socket features controlled depth, preventing contact with wheel when removing outer cap nuts

PROD. NO.	Size	Length
<b>684614</b>	33mm	98mm
<b>684616</b>	35mm	98mm
<b>684619</b>	38mm	98mm
<b>684622</b>	41mm	98mm
<b>684966</b>	1-1/2" controlled depth	98mm

### Extra Thin Wall Type - 6 Point Deep

- For use on Dayton-style lugnuts that are deeply recessed and where space is limited
- Extra thin wall sockets are not a warrantable item

PROD. NO.	Size	Length
<b>684943</b>	1-1/16"	108mm
<b>684944</b>	1-1/8"	108mm
<b>684946</b>	1-1/4"	108mm





## 1/2" DRIVE TORX® BIT SOCKET SETS

▼ *Hand Tools shown in this section feature:*

- Made of SNCM 8660 tool steel for 20% greater torque and 20% greater torsional resistance than regular Chrome Molybdenum bits
- Manganese Phosphate finish

### 10 PC - TORX®

610326 / PTB1210

3" OVERALL LENGTH TORX®

**T25 ,T27, T30, T40, T45, T50, T55, T60, T70, T80**

- Blow mould case



## 1/2" DRIVE HEX BIT SOCKET SETS

### 8 PC S.A.E. - Hex

610331 / PHB-1208

3" OVERALL LENGTH S.A.E.

**1/4, 5/16, 3/8, 7/16, 1/2, 9/16, 5/8, 3/4"**

- Blow mould case



### 8 PC Metric - Hex

610333 / PHB1208M

3" OVERALL LENGTH METRIC

**6, 7, 8, 10, 12, 14, 17, 19mm**

- Blow mould case



### 16 PC S.A.E./Metric - Hex

610340 / PHB-1216C

3" OVERALL LENGTH S.A.E.

**1/4, 5/16, 3/8, 7/16, 1/2, 9/16, 5/8, 3/4"**

3" OVERALL LENGTH METRIC

**6, 7, 8, 10, 12, 14, 17, 19mm**

- Set contains all popular sizes of hex bit power sockets!
- Blow mould case



TORX® is a registered trademark of Acument Intellectual Properties, LLC.

## 3/4" DRIVE HEX BIT SOCKET SETS



▼ *Hand Tools shown in this section feature:*

- Made of SNCM 8660 tool steel for 20% greater torque and 20% greater torsional resistance than regular Chrome Molybdenum bits
- Manganese Phosphate finish

### 5 PC S.A.E. - Hex

610411 / PHB-3405

3" OVERALL LENGTH S.A.E.

5/8, 3/4, 7/8, 1, 1-1/4"

- Blow mould case with removable lid



### 5 PC Metric - Hex

610421 / PHB3405M

3" OVERALL LENGTH METRIC

17, 19, 22, 24, 27mm

- Blow mould case with removable lid



## 3/8" & 1/2" DRIVE EXTERNAL TORX® SETS

- Sockets made of the finest quality S.A.E. 4140 Chrome Molybdenum high impact steel
- Set features the full range of popular external TORX® sizes
- Convenient blow mould case keeps sockets organized

### 17 PC - External TORX®

610391 / PTS17C

STANDARD LENGTH E-TORX® POWER SOCKETS:

- 3/8" Drive Sockets: **E5, E6, E7, E8, E10, E12, E14, E16**
- 1/2" Drive Sockets: **E10, E11, E12, E14, E16, E18, E20, E22, E24**
- Blow mould case





610903



610906



682939



682954

## SOCKET ACCESSORIES

### ▼ Hand Tools shown in this section feature:

- Sockets made of the finest quality S.A.E. 4140 Chrome Molybdenum high impact steel
- Meets or exceeds U.S. Federal Specs: GGG-W-660A and ANSI specifications

### Accessory Kits

- Blow mould case keeps all items organized and handy
- A great addition to any mechanics tool box

PROD. NO.	MOD. NO.	Description	Contains
610903	PSA3812-7	7 PC Impact Accessory Kit	3/8" dr. x 6" extension 3/8" dr. U Joint 3/8" F x 1/2" M adaptor 1/2" dr. x 5" extension 1/2" U Joint 1/2" F x 3/8" M adaptor 1/2" F x 3/4" M adaptor
610906	PSA3401-5	5 PC Impact Accessory Kit	3/4" dr. U Joint 1" dr. U Joint 3/4" F x 1/2" M adaptor 3/4" F x 1" M adaptor 1" F x 3/4" M adaptor



### 1/2" Drive Extra Thin Wall Flip Sockets

- Extra thin walls allows access to all recessed lugnuts where clearance is limited
- Thin wall impact sockets not a warrantable item

PROD. NO.	Length	Size
682938	76mm	3/4 x 13/16" hex
682939	76mm	19 x 21mm hex



### Extension Bars

PROD. NO.	Length	Drive
681953	3"	3/8"
681954	6"	3/8"
682954	5"	1/2"
682955	10"	1/2"
683951	6"	3/4"
683953	10"	3/4"
684951	6"	1"

### Socket Adaptors

- Socket adaptors do not carry lifetime warranty

PROD. NO.	Drive Female	Drive Male
681952	3/8"	1/2"
682952	1/2"	3/8"
682953	1/2"	3/4"
683952	3/4"	1/2"
683954	3/4"	1"
684952	1"	3/4"



681952

## Pin Free Impact Locking U-Joints

- Patented hex ball and socket design eliminates connecting pin for increased safety
- Ball and socket distributes force evenly for greater torque and longer life
- Eliminates broken connecting pins, the major source of U joint failures
- Drive anvil locks into straight position when flex function is not required
- Can be left on impact wrench and engaged only when needed



610901  
3 Piece Set



PROD. NO.	MOD. NO.	Drive Female & Male
-----------	----------	---------------------

### 3 PIECE SET

610901	PLUJ-3S	1/4, 3/8, 1/2"
--------	---------	----------------

### OPEN STOCK

680915	PLUJ-1414	1/4"
681915	PLUJ-3838	3/8"
682915	PLUJ-1212	1/2"



## Pin Free Impact U-Joint Adaptors

- Patented hex ball and socket design eliminates connecting pin for increased safety
- U-Joint adaptors do not carry lifetime warranty



610902  
5 Piece Set



PROD. NO.	MOD. NO.	Drive Female	Drive Male
-----------	----------	--------------	------------

### 5 PIECE SET

610902	PLUJ-5S	See Below	
--------	---------	-----------	--

### OPEN STOCK

680918	PLUJ-1438	1/4"	3/8"
681917	PLUJ-3814	3/8"	1/4"
681918	PLUJ-3812	3/8"	1/2"
682917	PLUJ-1238	1/2"	3/8"
682918	PLUJ-1234	1/2"	3/4"



## Universal Joints

PROD. NO.	Drive Female	Drive Male
681911	3/8"	3/8"
682911	1/2"	1/2"
683955	3/4"	3/4"
684955	1"	1"



682911

683955



## S.A.E. OPEN STOCK

▼ Hand Tools shown in this section feature:

- Sockets made of the finest quality S.A.E. 4140 Chrome Molybdenum high impact steel
- Meets or exceeds U.S. Federal Specs: GGG-W-660A and ANSI specifications

CrMo

Drive	3/8"	3/8"	1/2"	1/2"	1/2"	3/4"	3/4"	1"	1"	Drive	3/4"	1"	1"
Size S.A.E.	Regular 6 pt.	Deep 6 pt.	Regular 6 pt.	Deep 6 pt.	Universal Regular 6pt.	Regular 6 pt.	Deep 6 pt.	Regular 6 pt.	Deep 6 pt.	Size S.A.E.	Regular 6 pt.	Regular 6 pt.	Deep 6 pt.
5/16"	681110	681210								2-1/16"	683166	684165	684266
3/8"	681112	681212	682112	682212						2-1/8"	683168	684166	684268
7/16"	681114	681214	682114	682214						2-3/16"	683170	684167	684270
1/2"	681116	681216	682116	682216	682316					2-1/4"	683172	684168	684272
9/16"	681118	681218	682118	682218	682318					2-5/16"	683174	684169	684274
5/8"	681120	681220	682120	682220	682320					2-3/8"	683176	684170	684276
11/16"	681122	681222	682122	682222	682322					2-7/16"	683178	684171	684278
3/4"	681124	681224	682124	682224	682324	683124	683224	684124		2-1/2"	683180	684172	684280
13/16"	681126	681226	682126	682226	682326	683126	683226	684126		2-9/16"		684173	684282
7/8"	681128	681228	682128	682228	682328	683128	683228	684128	684228	2-5/8"		684174	684284
15/16"	681130	681230	682130	682230		683130	683230	684130	684230	2-11/16"		684175	
1"	681132	681232	682132	682232		683132	683232	684132	684232	2-3/4"		684176	684288
1-1/16"			682134	682234		683134	683234	684134	684234	2-13/16"		684177	
1-1/8"			682136	682236		683136	683236	684136	684236	2-7/8"		684178	
1-3/16"			682138	682238		683138	683238	684138	684238	2-15/16"		684179	
1-1/4"			682140	682240		683140	683240	684140	684240	3"		684180	
1-5/16"			682142	682242		683142	683242	684142	684242	3-1/8"		684182	
1-3/8"			682144	682244		683144	683244	684144	684244	3-1/4"		684184	
1-7/16"			682146	682246		683146	683246	684146	684246	3-3/8"		684186	
1-1/2"			682148	682248		683148	683248	684148	684248	3-1/2"		684188	
1-9/16"			682150	682250		683150	683250	684150	684250	3-5/8"		684190	
1-5/8"			682152	682252		683152	683252	684152	684252	3-3/4"		684192	
1-11/16"			682154	682254		683154	683254	684154	684254	3-7/8"		684194	
1-3/4"			682156	682256		683156	683256	684156	684256	4"		684196	
1-13/16"			682158	682258		683158	683258	684158	684258	4-1/8"		684197	
1-7/8"			682160	682260		683160	683260	684160	684260	4-1/4"		684198	
1-15/16"			682162	682262		683162	683262	684162	684262	4-1/2"		684199	
2"			682164	682264		683164	683264	684164	684264				





# METRIC OPEN STOCK



▼ Hand Tools shown in this section feature:

- Sockets made of the finest quality 4140 Chrome Molybdenum high impact steel
- Meets or exceeds U.S. Federal Specs: GGG-W-660A and ANSI specifications



Drive Metric (mm)	3/8"		1/2"		1/2"		3/4"	
	Regular 6 pt.	Deep 6 pt.	Regular 6 pt.	Deep 6 pt.	Universal Regular 6 pt.	Regular 6 pt.	Deep 6 pt.	
7mm	681507	681607						
8mm	681508	681608						
9mm	681509	681609						
10mm	681510	681610	682510	682610				
11mm	681511	681611	682511	682611				
12mm	681512	681612	682512	682612				
13mm	681513	681613	682513	682613	682713			
14mm	681514	681614	682514	682614	682714			
15mm	681515	681615	682515	682615	682715			
16mm	681516	681616	682516	682616	682716			
17mm	681517	681617	682517	682617	682717			
18mm	681518	681618	682518	682618	682718			
19mm	681519	681619	682519	682619	682719	683519	683619	
20mm			682520	682620				
21mm			682521	682621	682721	683521	683621	
22mm			682522	682622	682722	683522	683622	
23mm			682523	682623		683523	683623	
24mm			682524	682624		683524	683624	
25mm			682525	682625				
26mm			682526	682626		683526	683626	
27mm			682527	682627		683527	683627	
28mm			682528	682628				
29mm			682529	682629		683529	683629	
30mm			682530	682630		683530	683630	
32mm			682532	682632		683532	683632	
33mm			682533	682633		683533	683633	
34mm			682534	682634				
35mm			682535	682635		683535	683635	
36mm			682536	682636		683536	683636	
38mm						683538	683638	
41mm						683541	683641	
46mm						683546	683646	
50mm						683550	683650	



## HEX & TORX® BITS OPEN STOCK

▼ Hand Tools shown in this section feature:

- Made with premium quality SNCM8660 tool steel for 20% greater torsional resistance than Chrome Molybdenum bits



Drive	1/2"	3/4"	Drive	3/8"	1/2"	1/2"
Hex Bits	3" Length Hex Bit	3-1/2" Length Hex Bit	TORX® Bits	External Torx® Socket	External Torx® Socket	3" Length Torx® Bit
1/4"	687211		E5	688055		
5/16"	687212		E6	688056		
3/8"	687213		E7	688057		
7/16"	687214		E8	688058		
1/2"	687215		E10	688060	688110	
9/16"	687216		E11		688111	
5/8"	687217	687320	E12	688062	688112	
3/4"	687219	687324	E14	688064	688114	
7/8"		687328	E16	688066	688116	
1"		687332	E18		688118	
1-1/4"		687340	E20		688120	
6mm	687261		E22		688122	
7mm	687262		E24		688124	
8mm	687263		T25			687821
10mm	687265		T27			687822
12mm	687267		T30			687823
14mm	687269		T40			687825
17mm	687272	687367	T45			687826
19mm	687274	687369	T50			687827
22mm		687372	T55			687828
24mm		687374	T60			687829
27mm		687377	T70			687831
			T80			687833

TORX® is a registered trademark of Acument Intellectual Properties, LLC.



# Wrenches

- ADJUSTABLE WRENCHES
- RATCHETING WRENCHES
- COMBINATION WRENCHES
- STUBBY WRENCHES
- FLARE NUT / CROWFOOT

**TORQUE DRIVE**

700110



700115



700121



700177



700201

## COMBINATION WRENCHES - RAISED PANEL

▼ *Hand Tools shown in this section feature:*

- JET raised panel combination wrenches are made with industrial quality S.A.E. 6140 Chrome Vanadium steel (up to 1-1/4" or 32mm sizes)
- All wrenches feature TORQUE DRIVE® box ends for increased torque
- Wrench size stamped on head for easy identification
- Sets are supplied with industrial strength terylene pouches (\* except 700201)
- All sets meet ANSI specifications

### S.A.E. Wrench Sets

PROD. NO.	MOD. NO.	Pieces (Total)	Size
700110	CWS-6S	6	3/8, 7/16, 1/2, 9/16, 5/8, 3/4" Terylene Pouch
700115	CWS-11S	11	3/8, 7/16, 1/2, 9/16, 5/8, 11/16, 3/4, 13/16, 7/8, 15/16, 1", Terylene Pouch
700121	CWS-16S	16	1/4, 5/16, 3/8, 7/16, 1/2, 9/16, 5/8, 11/16, 3/4, 13/16, 7/8, 15/16, 1, 1-1/16, 1-1/8, 1-1/4", Terylene Pouch



### Metric Wrench Sets

PROD. NO.	MOD. NO.	Pieces (Total)	Size
700167	CWS-11M	11	8, 9, 10, 11, 12, 13, 14, 15, 17, 18, 19mm Terylene Pouch
700173	CWS-16M	16	7, 8, 9, 10, 11, 12, 13, 14, 15, 16, 17, 18, 19, 21, 22, 24mm, Terylene Pouch
700177	CWS-22M	22	7, 8, 9, 10, 11, 12, 13, 14, 15, 16, 17, 18, 19, 20, 21, 22, 23, 24, 26, 27, 30, 32mm Terylene Pouch



### S.A.E. / Metric Wrench Set

PROD. NO.	MOD. NO.	Pieces (Total)	Size
700201	CWS-32SM	32	1/4, 5/16, 3/8, 7/16, 1/2, 9/16, 5/8, 11/16, 3/4, 13/16, 7/8, 15/16, 1, 1-1/16, 1-1/8, 1-1/4", 7, 8, 9, 10, 11, 12, 13, 14, 15, 16, 17, 18, 19, 21, 22, 24mm

- Blow mould case



700510

## S.A.E. Jumbo Wrench Sets

- JET jumbo wrenches are made with industrial quality S45C Alloy Steel
- Extra heavy drop forgings and premium curved shaft edges ensure maximum strength and comfort
- Not available with TORQUE DRIVE®

PROD. NO.	MOD. NO.	Pieces (Total)	Size
<b>700125</b>	JCW-6	6	1-3/8, 1-1/2, 1-5/8, 1-3/4, 1-7/8, 2"
<b>700128</b>	JCW-10-2	10	1-5/16, 1-3/8, 1-7/16, 1-1/2, 1-5/8, 1-11/16, 1-3/4, 1-13/16, 1-7/8, 2"



## S.A.E. Wrenches - Open Stock

- S.A.E. 6140 CrV steel

PROD. NO.	Size
<b>700501</b>	1/4"
<b>700502</b>	5/16"
<b>700503</b>	3/8"
<b>700504</b>	7/16"
<b>700505</b>	1/2"
<b>700506</b>	9/16"
<b>700507</b>	5/8"
<b>700508</b>	11/16"
<b>700509</b>	3/4"
<b>700510</b>	13/16"
<b>700511</b>	7/8"
<b>700512</b>	15/16"
<b>700513</b>	1"
<b>700514</b>	1-1/16"
<b>700515</b>	1-1/8"
<b>700517</b>	1-1/4"



## S.A.E. Jumbo Wrenches - Open Stock

- S45C alloy steel

PROD. NO.	Size
<b>700518</b>	1-5/16"
<b>700519</b>	1-3/8"
<b>700520</b>	1-7/16"
<b>700521</b>	1-1/2"
<b>700523</b>	1-5/8"
<b>700524</b>	1-11/16"
<b>700525</b>	1-3/4"
<b>700526</b>	1-13/16"
<b>700527</b>	1-7/8"
<b>700529</b>	2"
<b>700531</b>	2-1/8"
<b>700533</b>	2-1/4"
<b>700535</b>	2-3/8"
<b>700537</b>	2-1/2"

## Metric Wrenches - Open Stock

- S.A.E. 6140 CrV steel

PROD. NO.	Size
<b>700552</b>	7mm
<b>700553</b>	8mm
<b>700554</b>	9mm
<b>700555</b>	10mm
<b>700556</b>	11mm
<b>700557</b>	12mm
<b>700558</b>	13mm
<b>700559</b>	14mm
<b>700560</b>	15mm
<b>700561</b>	16mm
<b>700562</b>	17mm
<b>700563</b>	18mm
<b>700564</b>	19mm
<b>700565</b>	20mm
<b>700566</b>	21mm
<b>700567</b>	22mm
<b>700568</b>	23mm
<b>700569</b>	24mm
<b>700571</b>	26mm
<b>700572</b>	27mm
<b>700575</b>	30mm
<b>700577</b>	32mm



**TORQUE DRIVE**

700134

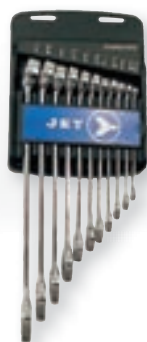

700132



700182



700185



700136



700186

## COMBINATION WRENCHES - FULLY POLISHED

▼ Hand Tools shown in this section feature:

- Exclusive TORQUE DRIVE® non-slip open ends
- Extra long pattern design allows greater torque and improved access to hard to reach areas
- Super strong S.A.E. 6140 Chrome Vanadium steel for strength and durability
- 15° offset - optimal for most applications
- Fully polished mirror finish
- Extra slim design allows access to the most confined spaces
- All wrenches meet ASME B107.6 and ASME B107.9M ANSI specifications

### Long Pattern S.A.E. Wrench Sets

PROD. NO.	MOD. NO.	Pieces (total)	Size
700132	LCWS-11S	11	1/4, 5/16, 3/8, 7/16, 1/2, 9/16, 5/8, 11/16, 3/4, 13/16, 7/8" Plastic Rack
700134	LCWS-14S	14	3/8, 7/16, 1/2, 9/16, 5/8, 11/16, 3/4, 13/16, 7/8, 15/16, 1, 1-1/16, 1-1/8, 1-1/4" Terylene Pouch



### Long Pattern Metric Wrench Sets

PROD. NO.	MOD. NO.	Pieces (total)	Size
700182	LCWS-11M	11	8, 9, 10, 11, 12, 13, 14, 15, 17, 18, 19mm Plastic Rack
700185	LCWS-16M	16	7, 8, 9, 10, 11, 12, 13, 14, 15, 16, 17, 18, 19, 21, 22, 24mm Terylene Pouch



### Extra Long Pattern - Sets

- Same quality features as shown above
- Extra length for hard-to-reach fasteners and greater torque

PROD. NO.	MOD. NO.	Pieces (total)	Size
700136	LCWS-11XLS	11	1/4, 5/16, 3/8, 7/16, 1/2, 9/16, 5/8, 11/16, 3/4, 13/16, 7/8" Plastic Rack
700186	LCWS-11XLM	11	8, 9, 10, 11, 12, 13, 14, 15, 17, 18, 19mm Plastic Rack



# COMBINATION WRENCHES - FULLY POLISHED



## Long Pattern S.A.E. Wrenches - Open Stock

PROD. NO.	Size
700621	1/4"
700622	5/16"
700623	3/8"
700624	7/16"
700625	1/2"
700626	9/16"
700627	5/8"
700628	11/16"
700629	3/4"
700630	13/16"
700631	7/8"
700632	15/16"
700633	1"
700634	1-1/16"
700635	1-1/8"
700637	1-1/4"



## Long Pattern Metric Wrenches - Open Stock

PROD. NO.	Size
700672	7mm
700673	8mm
700674	9mm
700675	10mm
700676	11mm
700677	12mm
700678	13mm
700679	14mm
700680	15mm
700681	16mm
700682	17mm
700683	18mm
700684	19mm
700685	20mm
700686	21mm
700687	22mm
700688	23mm
700689	24mm



## Extra Long Pattern - Open Stock

### S.A.E.

PROD. NO.	Size
700801	1/4"
700802	5/16"
700803	3/8"
700804	7/16"
700805	1/2"
700806	9/16"
700807	5/8"
700808	11/16"
700809	3/4"
700810	13/16"
700811	7/8"

### Metric

700853	8mm
700854	9mm
700855	10 mm
700856	11mm
700857	12mm
700858	13mm
700859	14mm
700860	15mm
700862	17mm
700863	18mm
700864	19mm



**ANOTHER JET ADVANTAGE**

Non-slip open ends in series:  
**FULLY POLISHED COMBINATION WRENCHES**

**EXTRA LONG FULLY POLISHED COMBINATION WRENCHES**

All wrenches feature **TORQUE DRIVE®** box ends for increased torque



All professional wrenches in this category feature exclusive "non-slip" open ends for increased torque and use on rounded fasteners

**TORQUE DRIVE®**

## COMBINATION WRENCHES - MULTI-FIT

### ▼ Hand Tools shown in this section feature:

- Multi-fit box end fits S.A.E. and Metric 6 pt. hex and 12 pt. double hex fasteners, as well as 4 pt. Spline and TORX® fasteners
- Patented open end fits S.A.E. and Metric 6 pt. hex and 4 pt. square fasteners
- Permits use on fasteners when box end cannot be slipped over rod or bolt
- Competing open end designs require the user to purchase separate S.A.E. and Metric sets
- 8 PC set fits 63 different sizes and types of fasteners providing unparalleled versatility
- Super strong SAE 6140 Chrome Vanadium steel for strength and durability
- 15° offset – ideal for most applications
- Fully polished mirror finish with 3 layers of plating for superior corrosion resistance

**NEW**



### 8 PC Multi-Fit Combination Wrench Set

PROD. NO.	MOD. NO.	Pieces (total)	Size
700212	CWMF-8S	8	See below



### Multi-Fit - Open Stock

BOX END FITS:	6 & 12 pt S.A.E.	6 & 12 pt Metric	4 pt S.A.E.	4 pt Metric	Spline	TORX®
700453	5/16	8	9/32	7	8	E10
700455	3/8	10	11/32	-	10	E12
700456	7/16	11	3/8	9	11	E14
700458	1/2	13	7/16	11	13	E16
700459	9/16	14	15/32	12	14	E18
700461	5/8	16	17/32	13	16	E20
700462	11/16	17	9/16	14	17	E22
700464	3/4	19	5/8	16	19	E24

OPEN END FITS:	6 pt S.A.E.	6 pt Metric	4 pt S.A.E.	4 pt Metric
700453	5/16	8	5/16	8
700455	3/8	10	3/8	10
700456	7/16	11	7/16	11
700458	1/2	13	1/2	13
700459	9/16	14	9/16	14
700461	5/8	16	5/8	16
700462	11/16	17	11/16	17
700464	3/4	19	3/4	18





# COMBINATION WRENCHES - STUBBY POLISHED

▼ *Hand Tools shown in this section feature:*

- Extra short pattern style allows you to access confined areas
- Fully polished for clean professional look and feel
- 12 point TORQUE DRIVE® box end applies force to sides of fasteners, reducing corner rounding and allowing 20% more torque
- 15° offset is optimal for most applications
- Heavy duty drop forged S.A.E. 6140 Chrome Vanadium steel made for professionals
- Meets ANSI Standards

## Stubby S.A.E. Wrench Set

PROD. NO.	MOD. NO.	Pieces (total)	Size
<b>700141</b>	SCWS-7S	7	3/8, 7/16, 1/2, 9/16, 5/8, 11/16, 3/4" Plastic Rack



## Stubby Metric Wrench Set

PROD. NO.	MOD. NO.	Pieces (total)	Size
<b>700191</b>	SCWS-7M	7	10, 12, 13, 15, 17, 18, 19mm Plastic rack



## Stubby S.A.E. Wrenches - Open Stock

PROD. NO.	Size
<b>700703</b>	3/8"
<b>700704</b>	7/16"
<b>700705</b>	1/2"
<b>700706</b>	9/16"
<b>700707</b>	5/8"
<b>700708</b>	11/16"
<b>700709</b>	3/4"



## Stubby Metric Wrenches - Open Stock

PROD. NO.	Size
<b>700755</b>	10mm
<b>700757</b>	12mm
<b>700758</b>	13mm
<b>700760</b>	15mm
<b>700762</b>	17mm
<b>700763</b>	18mm
<b>700764</b>	19mm



700141



700191



**TORQUE DRIVE**

**TORQUE DRIVE®**

700308



700312



700164

## RATCHETING WRENCH - SETS

▼ *Hand Tools shown in this section feature:*

- Exclusive TORQUE DRIVE® non-slip open ends & 12 point box ends for superior grip
- 72 tooth ratchet mechanism exceeds the ANSI torque ratings for a fixed wrench by more than 30%
- Superior grade 6140 Chrome Vanadium steel
- Flat style allows maximum access to confined areas - just flip wrench over to reverse
- Fully polished surface resists corrosion
- Complete with plastic carrying rack

### Non-Reversing

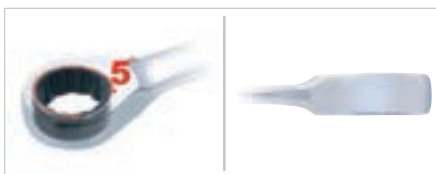

Flip wrench to reverse direction

### Long Pattern S.A.E. Wrench Sets - Non-Reversing

PROD. NO.	MOD. NO.	Pieces (total)	Size
<b>700308</b>	RCWS-8S	8	5/16, 3/8, 7/16, 1/2, 9/16, 5/8, 11/16, 3/4"
<b>700312</b>	RCWS-13S	13	1/4, 5/16, 3/8, 7/16, 1/2, 9/16, 5/8, 11/16, 3/4, 13/16, 7/8, 15/16, 1"



### Long Pattern Metric Wrench Sets - Non-Reversing

PROD. NO.	MOD. NO.	Pieces (total)	Size
<b>700164</b>	RCWS-7M	7	8, 10, 12, 13, 14, 15, 18mm Plastic Rack
<b>700361</b>	RCWS-12M	12	8, 9, 10, 11, 12, 13, 14, 15, 16, 17, 18, 19mm Plastic Rack



All professional wrenches in this category feature exclusive "non-slip" open ends for increased torque and use on rounded fasteners



700361

See page 101 for open stock wrenches

# RATCHETING WRENCH - SETS



## Reversing

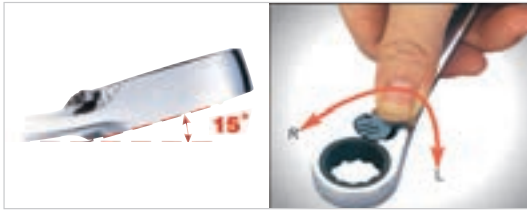

- Same great features as flat style, but with reversing lever
- Allows 15° offset for clearance
- Low profile lever does not add height to the box end, maintaining clearance
- Rated at 1.2 x ANSI torque values

## Long Pattern S.A.E. Wrench Sets - Reversing

PROD. NO.	MOD. NO.	Pieces (total)	Size
<b>700321</b>	RCWS-8SR	8	5/16, 3/8, 7/16, 1/2, 9/16, 5/8, 11/16, 3/4"
<b>700322</b>	RCWS-13SR	13	1/4, 5/16, 3/8, 7/16, 1/2, 9/16, 5/8, 11/16, 3/4, 13/16, 7/8, 15/16, 1"



## Long Pattern Metric Wrench Sets - Reversing

PROD. NO.	MOD. NO.	Pieces (total)	Size
<b>700371</b>	RCWS-7MR	7	8, 10, 12, 13, 14, 15, 18mm
<b>700372</b>	RCWS-12MR	12	8, 9, 10, 11, 12, 13, 14, 15, 16, 17, 18, 19mm



**JET** RATCHETING WRENCH      OTHER LEADING BRAND

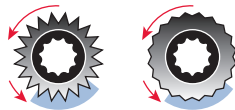

**JET's** deeper broached teeth allow up to 30% greater torque loads and ensure positive tooth engagement



700321



700322



700371



700372



700336



Extra long pattern ratcheting wrench is up to 25% longer than traditional wrenches

## RATCHETING WRENCH - SETS

▼ *Hand Tools shown in this section feature:*

- Exclusive TORQUE DRIVE® non-slip open ends & 12 point box ends for superior grip
- 72 tooth ratchet mechanism exceeds the ANSI torque ratings for a fixed wrench by more than 30%
- Superior grade 6140 Chrome Vanadium steel
- Flat style allows maximum access to confined areas - just flip wrench over to reverse
- Fully polished surface resists corrosion
- Complete with plastic carrying rack

### TORQUE DRIVE®

700386



#### Extra Long Pattern Wrench - Sets

- Extra length for hard-to-reach fasteners
- Up to 25% longer than traditional ratcheting wrenches

PROD. NO.	MOD. NO.	Pieces (total)	Size
<b>700336</b>	RCWS-9XLS	9	1/4, 5/16, 3/8, 7/16, 1/2, 9/16, 5/8, 11/16, 3/4"
<b>700386</b>	RCWS-12XLM	12	8, 9, 10, 11, 12, 13, 14, 15, 16, 17, 18, 19mm



700331

700381

Flex head design  
180° swing

#### Long Pattern Flex Head Wrench - Sets

- Flex head design allows up to 180° flex for increased access to confined areas
- Light tension holds position while allowing easy adjustment of angle

PROD. NO.	MOD. NO.	Pieces (total)	Size
<b>700331</b>	RCWS-11FS	11	1/4, 5/16, 3/8, 7/16, 1/2, 9/16, 5/8, 11/16, 3/4, 13/16, 7/8"
<b>700381</b>	RCWS-11FM	11	8, 9, 10, 11, 12, 13, 14, 15, 17, 18, 19mm



See page 101 for open stock wrenches



### S.A.E. Open Stock - Non-Reversing

PROD. NO.	Size
701101	1/4"
701102	5/16"
701103	3/8"
701104	7/16"
701105	1/2"
701106	9/16"
701107	5/8"
701108	11/16"
701109	3/4"
701110	13/16"
701111	7/8"
701112	15/16"
701113	1"

### Metric Open Stock - Non-Reversing

PROD. NO.	Size
701153	8mm
701154	9mm
701155	10mm
701156	11mm
701157	12mm
701158	13mm
701159	14mm
701160	15mm
701161	16mm
701162	17mm
701163	18mm
701164	19mm

### S.A.E. Open Stock - Reversing

PROD. NO.	Size
701121	1/4"
701122	5/16"
701123	3/8"
701124	7/16"
701125	1/2"
701126	9/16"
701127	5/8"
701128	11/16"
701129	3/4"
701130	13/16"
701131	7/8"
701132	15/16"
701133	1"

### Metric Open Stock - Reversing

PROD. NO.	Size
701173	8mm
701174	9mm
701175	10mm
701176	11mm
701177	12mm
701178	13mm
701179	14mm
701180	15mm
701181	16mm
701182	17mm
701183	18mm
701184	19mm



### S.A.E. Extra Long - Open Stock Non-Reversing

PROD. NO.	Size
701201	1/4"
701202	5/16"
701203	3/8"
701204	7/16"
701205	1/2"
701206	9/16"
701207	5/8"
701208	11/16"
701209	3/4"

### Metric Extra Long - Open Stock Non-Reversing

PROD. NO.	Size
701253	8mm
701254	9mm
701255	10mm
701256	11mm
701257	12mm
701258	13mm
701259	14mm
701260	15mm
701261	16mm
701262	17mm
701263	18mm
701264	19mm

### S.A.E. Flex Head - Open Stock Non-Reversing

PROD. NO.	Size
701301	1/4"
701302	5/16"
701303	3/8"
701304	7/16"
701305	1/2"
701306	9/16"
701307	5/8"
701308	11/16"
701309	3/4"
701310	13/16"
701311	7/8"

### Metric Flex Head - Open Stock Non-Reversing

PROD. NO.	Size
701353	8mm
701354	9mm
701355	10mm
701356	11mm
701357	12mm
701358	13mm
701359	14mm
701360	15mm
701362	17mm
701363	18mm
701364	19mm

## RATCHETING WRENCHES

### 12-in-1 Ratcheting Box End Wrench Set

- Two wrenches replace a full 24 piece set - ideal for tool pouches
- Unique broaching accurately fits S.A.E., Metric, and E-TORX fasteners
- Each opening fits 3 different fasteners - 6 per end, 12 per wrench!
- 72 teeth for low swing room - just 5° swing to engage teeth
- Reverse switch at each end
- Highest quality Chrome Vanadium Steel for professional use

700391



PROD. NO.	MOD. NO.	Pieces (total)	Fits
<b>700391</b>	DBRW-2S	2	See <b>701191</b> and <b>701193</b>
<b>701191</b>	—	1	5/16, 3/8, 7/16, 1/2", 8, 10, 11, 13mm, E10, E12, E14, E16
<b>701193</b>	—	1	9/16, 5/8, 11/16, 3/4", 14, 16, 17, 19mm, E18, E20, E22, E24



**700391**  
Available in  
10 piece POP  
Display Case

### 4 PC Ratchet Wrench Adaptor Set

701196 / RWAS-4

- 1/4", 3/8", and 1/2" socket adaptors and 1/4" hex bit adaptor provide maximum versatility by turning your ratcheting wrench set into a full wrench, bit, and socket drive set
- Converts the wrench into an extremely low profile ratchet for access to the most limited spaces
- Works with flat, reversing, and flex head ratcheting combination wrenches
- Requires 3/8", 1/2", and 3/4" ratcheting wrenches (sold separately)
- Available in 4 pc set only

#### CONTENTS:

- **1/4" hex bit adaptor** for use with 3/8" ratcheting wrench
- **1/4" drive socket adaptor** for use with 3/8" ratcheting wrench
- **3/8" drive socket adaptor** for use with 1/2" ratcheting wrench
- **1/2" drive socket adaptor** for use with 3/4" ratcheting wrench
- Ratchet wrenches sold separately

Adaptor set  
converts ratcheting  
combination  
wrenches to socket  
or bit drivers



Socket adaptors  
complete with quick  
release feature



# FLARE NUT WRENCHES

▼ *Hand Tools shown in this section feature:*

- Flare nut wrenches are used on fasteners found on tubing ends or hoses, such as brake lines, hydraulic fittings, plumbing, etc
- Slot opening easily slides over tubing or hose to reach hex nuts at ends
- 6 point design allows for maximum contact on fastener for evenly distributed torque
- Reduces fastener damage

## Flare Nut Wrench Sets

PROD. NO.	MOD. NO.	Type	Pieces (total)	Size	Holder
<b>719001</b>	FN-3	S.A.E.	3	3/8" x 7/16" 1/2" x 9/16" 5/8" x 11/16"	Plastic Pouch
<b>719006</b>	FN-3M	Metric	3	10 x 11mm 12 x 13mm 15 x 17mm	Plastic Pouch



## Flare Nut Wrenches - Open Stock

PROD. NO.	Type	Size
<b>719002</b>	S.A.E.	3/8" x 7/16"
<b>719003</b>	S.A.E.	1/2" x 9/16"
<b>719004</b>	S.A.E.	5/8" x 11/16"
<b>719007</b>	Metric	10 x 11mm
<b>719008</b>	Metric	12 x 13mm
<b>719009</b>	Metric	15 x 17mm

# CROWFOOT WRENCHES

## Sets with Rail

- Used in restricted access spaces where a flare nut wrench cannot reach
- Slot opening easily slides over tubing or hose to reach hex nuts at ends
- Fully polished

PROD. NO.	MOD. NO.	Pieces	Drive	Size	Holder
<b>719111</b>	FNC-8	8	3/8"	3/8, 7/16, 1/2, 9/16, 5/8, 11/16, 3/4, 7/8"	Socket Rail
<b>719121</b>	FNC-10M	10	3/8"	10, 11, 12, 13, 14, 15, 16, 17, 18, 19mm	Socket Rail



**NEW**

711102



- Professional quality
- Drop forged Chrome Vanadium steel
- Fully heat treated for strength and durability
- Accurately machined sliding jaw for smooth adjustment
- Traditional handle design

#### Adjustable Wrenches Set - Standard duty

PROD. NO.	MOD. NO.	Length	Pieces	Opening	Material
<b>711102</b>	AW-3S5	<b>8", 10", 12"</b>	3	1", 1-1/4", 1-1/2"	CrV

CrV

**NEW**

#### Adjustable Wrenches - Open Stock

PROD. NO.	MOD. NO.	Length	Opening	Material
<b>711111</b>	AW-4	<b>4" (100 mm)</b>	1	CrV
<b>711112</b>	AW-6	<b>6" (160 mm)</b>	3/4"	CrV
<b>711113</b>	AW-8	<b>8" (210 mm)</b>	1"	CrV
<b>711114</b>	AW-10	<b>10" (250 mm)</b>	1-1/4"	CrV
<b>711115</b>	AW-12	<b>12" (300 mm)</b>	1-1/2"	CrV
<b>711116</b>	AW-15	<b>15" (380 mm)</b>	1-7/8"	Alloy
<b>711117</b>	AW-18	<b>18" (450 mm)</b>	2-1/8"	Alloy
<b>711118</b>	AW-24	<b>24" (600 mm)</b>	2-1/2"	Alloy

CrV

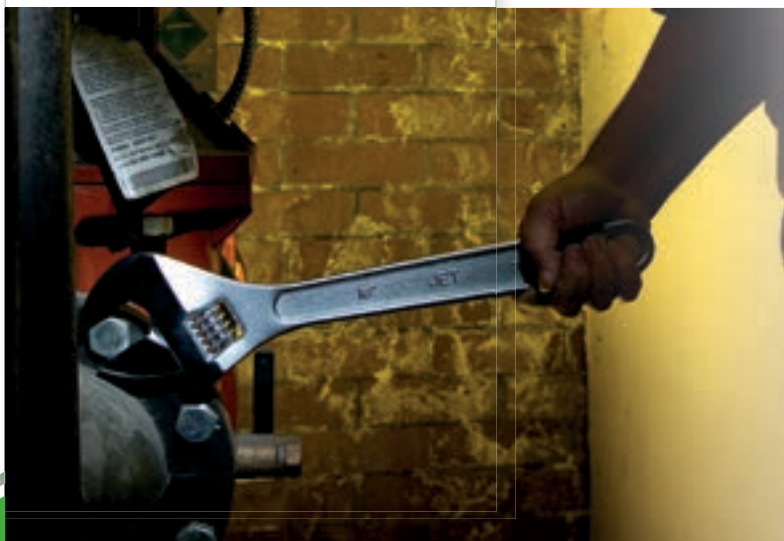



# ADJUSTABLE WRENCHES



## Professional Adjustable Wrenches - Super Heavy Duty

- Smaller 15° jaw angle provides greater leverage than standard 22° wrenches, reducing hand and arm fatigue
- Extra wide jaw openings fit an increased range of fasteners, offering greater versatility and value
- Thin tapered jaw reaches fasteners in narrow spaces with ease
- Jaw rack does not protrude past jaw when wrench is fully open, increasing clearance in tight access areas
- Thicker handle provides improved comfort and allows increased application of force
- S.A.E. and Metric scales laser printed on jaws for convenient sizing of fasteners

PROD. NO.	MOD. NO.	Length	Opening	Material
711132	AWP-6	6" (160 mm)	7/8"	CrV
711133	AWP-8	8" (210 mm)	1"	CrV
711134	AWP-10	10" (250 mm)	1-3/16"	CrV
711135	AWP-12	12" (300 mm)	1-3/8"	CrV
711136	AWP-15	15" (380 mm)	1-15/16"	CrV
711137	AWP-18	18" (450 mm)	2-3/8"	CrV
711139	AWP-24	24" (600 mm)	2-1/2"	CrV



Convenient scales



## Industrial Adjustable Wrenches - Black Phosphate Finish - Super Heavy Duty

- Chrome Vanadium steel wrenches with black phosphate finish for use in applications where plated products are prohibited
- No chrome plate to peel or chip, causing contamination in sensitive applications
- Finish is non-reflective for military applications
- Black phosphate provides superior corrosion resistance versus black oxide finishes

PROD. NO.	MOD. NO.	Length	Opening	Material
711152	AWP-6B	6" (160 mm)	15/16"	CrV
711153	AWP-8B	8" (210 mm)	1-1/8"	CrV
711154	AWP-10B	10" (250 mm)	1-1/4"	CrV
711155	AWP-12B	12" (300 mm)	1-1/2"	CrV
711156	AWP-15B	15" (380 mm)	1-31/32"	CrV
711157	AWP-18B	18" (450 mm)	2-3/8"	CrV
711159	AWP-24B	24" (600 mm)	2-3/4"	CrV



711157

711154





715216

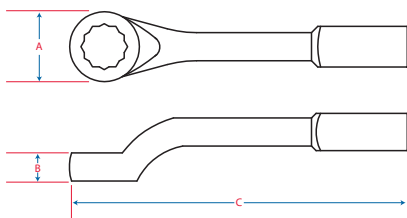

Special chamfering keeps wrench on fastener

## STRIKING WRENCHES

### S.A.E. - Offset Style

- Drop forged Chrome Vanadium steel
- Heat treated for maximum strength
- Offset design allows clearance over work
- 12 point design for decreased swing room
- Special chamfering keeps wrench on fastener
- Protective coating minimizes corrosion
- Meets US Government standard GGG-W-636E and ANSI specifications
- 35 hex sizes from 1 - 3-1/8"

PROD. NO.	Size	Head Width (A)	Head Thickness (B)	Overall Length (C)
715201	1"	1-25/32"	25/32"	10-5/8"
715202	1-1/16"	1-25/32"	25/32"	10-5/8"
715203	1-1/8"	1-15/16"	7/8"	11"
715204	1-3/16"	1-15/16"	7/8"	11"
715205	1-1/4"	2-3/32"	29/32"	11-7/16"
715206	1-5/16"	2-3/32"	29/32"	11-7/16"
715207	1-3/8"	2-7/16"	31/32"	11-13/16"
715208	1-7/16"	2-7/16"	31/32"	11-13/16"
715209	1-1/2"	2-5/8"	1-1/32"	12-5/8"
715210	1-9/16"	2-5/8"	1-1/32"	12-5/8"
715211	1-5/8"	2-5/8"	1-1/32"	12-5/8"
715212	1-11/16"	2-5/8"	1-1/32"	12-5/8"
715213	1-3/4"	2-7/8"	1-1/16"	13-3/8"
715214	1-13/16"	2-7/8"	1/1/16"	13-3/8"
715215	1-7/8"	2-7/8"	1-1/16"	13-3/8"
715216	1-15/16"	3-1/16"	1-1/4"	13-3/4"
715217	2"	3-1/16"	1-1/4"	13-3/4"
715218	2-1/16"	3-5/16"	1-5/16"	4-3/16"
715219	2-1/8"	3-5/16"	1-5/16"	14-3/16"
715220	2-3/16"	3-5/16"	1-5/16"	14-3/16"
715221	2-1/4"	3-17/32"	1-3/8"	14-3/4"
715222	2-5/16"	3-17/32"	1-3/8"	14-3/4"
715223	2-3/8"	3-17/32"	1-3/8"	14-3/4"
715224	2-7/16"	3-17/32"	1-3/8"	14-3/4"
715225	2-1/2"	3-25/32"	1-1/2"	15-3/8"
715226	2-9/16"	3-25/32"	1-1/2"	15-3/8"
715227	2-5/8"	3-25/32"	1-1/2"	15-3/8"
715228	2-11/16"	4-1/8"	1-5/8"	15-3/4"
715229	2-3/4"	4-1/8"	1-5/8"	15-3/4"
715230	2-13/16"	4-1/8"	1-5/8"	15-3/4"
715231	2-7/8"	4-11/32"	1-11/16"	16-9/16"
715232	2-15/16"	4-11/32"	1-11/16"	16-9/16"
715233	3"	4-11/32"	1-11/16"	16-9/16"
715234	3-1/16"	4-21/32"	1-25/32"	17-5/16"
715235	3-1/8"	4-21/32"	1-25/32"	17-5/16"



# STRUCTURAL WRENCHES



▼ **Hand Tools shown in this section feature:**

- Drop forged Chrome Vanadium steel
- Heat treated for maximum strength
- Offset design allows clearance over work
- Round tapered stock allows use as aligning bar
- Protective coating minimizes corrosion
- Meets US government standard GGG-W-636E

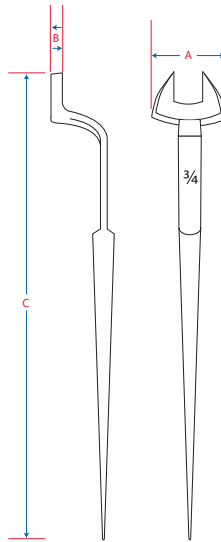

### S.A.E. - Offset Style

PROD. NO.	Size	Head Width (A)	Head Thickness (B)	Overall Length (C)
719151	3/4"	1-3/4"	13/32"	13-1/8"
719153	7/8"	2-9/32"	7/16"	13-3/4"
719154	15/16"	2-9/32"	7/16"	14-5/8"
719155	1"	2-9/32"	7/16"	14-5/8"
719156	1-1/16"	2-9/32"	7/16"	14-5/8"
719157	1-1/8"	2-1/2"	19/32"	14-5/8"
719159	1-1/4"	2-1/2"	19/32"	15-3/4"
719162	1-7/16"	3-1/16"	23/32"	16-7/8"
719163	1-1/2"	3-1/16"	23/32"	18-1/2"
719165	1-5/8"	3-5/8"	23/32"	18-1/2"



719151

### 15" Adjustable Construction Wrench

- Drop forged heat treated steel for professional use
- Adjustable up to 1-5/8" for maximum convenience
- Eliminates the need to carry multiple wrenches
- Tapered shaft aids in aligning bolt holes
- Continuous taper reduces binding
- Precisely ground jaws remain parallel at all opening widths for better grip
- Ultra smooth acting knurl for fast adjustment
- Flat neck allows use of lanyard for added safety



PROD. NO.	MOD. NO.	Head Width (A)	Head Thickness (B)	Overall Length (C)
711146	AWC-15	3-1/2"	5/8"	15-3/4"





## ADJUSTABLE SPANNER WRENCHES

▼ *Hand Tools shown in this section feature:*

- Black oxide finish resists corrosion
- Adjustable wrenches fit a wide variety of sizes
- Slotted or pin style wrenches
- For use on collars, locknut rings and bearings



710904

### Hook Style

PROD. NO.	MOD. NO.	Length	Capacity	Type
<b>710902</b>	JHSW-102	6-1/2"	3/4 - 2"	Hook
<b>710903</b>	JHSW-103	8"	1-1/4 - 3"	Hook
<b>710904</b>	JHSW-104	11-1/2"	2 - 4-3/4"	Hook



710914

### Pin Style

PROD. NO.	MOD. NO.	Length	Capacity	Pin Size	Type
<b>710912</b>	JPSW-102	6-1/2"	3/4 - 2"	<b>1/8"</b>	Pin
<b>710913</b>	JPSW-103	8"	1-1/4 - 3"	<b>3/16"</b>	Pin
<b>710914</b>	JPSW-104	11-1/2"	2 - 4-3/4"	<b>1/4"</b>	Pin



# Hex Key Wrenches



FOLDING  
SHORT AND LONG ARM  
BALL NOSE  
HEX AND TORX  
JUMBO STYLE  
L-HANDLE



775144



775146



775153



775156



775192



775112



775114



775191

## HEX KEY WRENCHES - SETS

### Folding Hex and TORX® Key Sets

- Fully hardened steel case with ergonomic bi-material grip for added comfort and sure grip
- Steel reinforced on inside for maximum strength
- Heat treated Chrome Vanadium steel keys
- Unique offset washers between keys applies tension, holding keys firmly in place while in use

PROD. NO.	MOD. NO.	Pieces	Sizes
775144	JFHK-9	9	5/64, 3/32, 7/64, 1/8, 9/64, 5/32, 3/16, 7/32, 1/4"
775146	JFHK-7L	7	1/8, 5/32, 3/16, 7/32, 1/4, 5/16, 3/8"
775153	JFHK-7M	7	1.5, 2, 2.5, 3, 4, 5, 6mm
775156	JFHK-7ML	7	3, 4, 5, 5.5, 6, 8, 10mm
775192	JFTK-8	8	T8, T10, T15, T20, T25, T27, T30, T40



### Short Arm Hex and TORX® Key Sets

- Precision chamfering for ease of insertion
- Industrial heat treated Chrome Vanadium steel
- Convenient carrying case keeps hex keys organized

PROD. NO.	MOD. NO.	Pieces	Sizes
775112	JHK-13	13	0.05, 1/16, 5/64, 3/32, 7/64, 1/8, 9/64, 5/32, 3/16, 7/32, 1/4, 5/16, 3/8"
775114	JHK-9M	9	1.5, 2.0, 2.5, 3.0, 4.0, 5.0, 6.0, 8.0, 10mm
775191	JTK-9TP	9	T10, T15, T20, T25, T27, T30, T40, T45, T50



TORX® is a registered trademark of Acument Intellectual Properties, LLC.



# HEX KEY WRENCHES - SETS



## Long Arm Ball Nose Sets

- Long arm series allows access into tough spots and more torque on the fastener
- Ball nose design allows engagement of fastener at up to 25° angle
- Precision chamfering for ease of insertion
- Industrial heat treated Chrome Vanadium steel
- Convenient carrying case keeps hex keys organized
- 22 PC sets combines 13 PC S.A.E. and 9 PC Metric with a convenient centre post that converts to a comfortable T or L-Handle
- All items meet ANSI standards for hardness and torque



775164

PROD. NO.	MOD. NO.	Pieces	Sizes
775164	JBHK-22SM	22	0.05, 1/16, 5/64, 3/32, 7/64, 1/8, 9/64, 5/32, 3/16, 7/32, 1/4, 5/16, 3/8" 1.5, 2.0, 2.5, 3.0, 4.0, 5.0, 6.0, 8.0, 10.0mm
775173	JBHK-10	10	1/16, 5/64, 3/32, 1/8, 5/32, 3/16, 7/32, 1/4, 5/16, 3/8"
775184	JBHK-9M	9	1.5, 2.0, 2.5, 3.0, 4.0, 5.0, 6.0, 8.0, 10.0mm



## Long Arm Flat Nose

- Same quality features as above, except with flat nose at both ends of the hex key

PROD. NO.	MOD. NO.	Pieces	Sizes
775162	JHK-22SM	22	0.05, 1/16, 5/64, 3/32, 7/64, 1/8, 9/64, 5/32, 3/16, 7/32, 1/4, 5/16, 3/8" 1.5, 2.0, 2.5, 3.0, 4.0, 5.0, 6.0, 8.0, 10.0mm



## Extra Long Ball Nose Sets

- Extra long - up to 30% longer than conventional hex long arm keys. Improves reach and provides more torque
- Hex end for extra torque - use for initial loosening and final tightening
- Ball nose allows angle entry - perfect for blind applications
- Super bright finish for excellent rust resistance
- S2 alloy steel hardened to HRC58-62 allows 50% more torque than CrV keys
- Improved folding case for easier access to smaller sizes
- Exceeds ANSI standards for hardness and torque

PROD. NO.	MOD. NO.	Pieces	Sizes
775175	JBHK-9XL	9	1/16, 5/64, 3/32, 1/8, 5/32, 3/16, 1/4, 5/16, 3/8"
775185	JBHK-9XLM	9	1.5, 2.0, 2.5, 3.0, 4.0, 5.0, 6.0, 8.0, 10.0mm



775173

775184



775162



775175

775185

TORX® is a registered trademark of Acument Intellectual Properties, LLC.



775186



774619

774699



775104

## HEX KEY WRENCHES - SETS

### Jumbo Extra Long Ball Nose Sets

- Same great features our Extra Long Ball Nose series except with larger sizes for all heavy duty applications
- Complete with handy organizer

PROD. NO.	MOD. NO.	Pieces	Sizes
<b>775176</b>	JBHK-17XL	17	0.05, 1/16, 5/64, 3/32, 7/64, 1/8, 9/64, 5/32, 3/16, 7/32, 1/4, 5/16, 3/8, 1/2, 9/16, 5/8, 3/4"
<b>775186</b>	JBHK-17LM	17	1.3, 1.5, 2.0, 2.5, 3.0, 3.5, 4.0, 5.0, 5.5, 6.0, 7.0, 8.0, 10, 12, 14, 17, 19mm



### L-Handle Style Hex and TORX® Key Sets

- Hard composite material combined with soft rubber form a unique ergonomic handle for optimal grip and unsurpassed comfort
- Handles are moulded around keys ensuring maximum strength and preventing keys and handles from separating
- S2 alloy steel hardened to HRC58-62 allows 50% more torque than CrV keys
- Super long keys for maximum reach - our longest hex keys
- Ball nose allows angle entry - perfect for blind applications (Hex Key Only)
- Short end for extra torque - use for initial loosening and final tightening
- TORX® keys are regular style on one end and tamperproof on the other
- Super bright finish for excellent rust resistance
- Exceeds ANSI standards for hardness and torque
- Comes with blow mould case

PROD. NO.	MOD. NO.	Pieces	Sizes
<b>775104</b>	JTHK-9	9	5/64, 3/32, 1/8, 5/32, 3/16, 7/32, 1/4, 5/16, 3/8"
<b>775106</b>	JTHK-9M	9	2.0, 2.5, 3.0, 4.0, 5.0, 5.5, 6.0, 8.0, 10.0mm
<b>775108</b>	JTTK-9	9	T10, T15, T20, T25, T27, T30, T40, T45, T50





# HEX KEY WRENCHES

## Short/Long Arm Combination S.A.E./Metric Set

- Keys made of heat treated Chrome Vanadium steel
- Quality set at an economical price
- S.A.E. keys are long arm, Metric keys are short arm
- Complete with blow mould carrying case

PROD. NO.	MOD. NO.	Pieces	Sizes
-----------	----------	--------	-------

<b>775165</b>	JHK-25SM	25	<b>Long Arm</b> 1/16, 5/64, 3/32, 7/64, 1/8, 9/64, 5/32, 3/16, 7/32, 1/4, 5/16, 3/8" <b>Short Arm</b> 1.5, 2.0, 2.5, 3.0, 4.0, 4.5, 5.0, 5.5, 6.0, 7.0, 8.0, 9.0, 10.0mm
---------------	----------	----	--------------------------------------------------------------------------------------------------------------------------------------------------------------------------------------------



## TORX® KEY WRENCHES - OPEN STOCK

Set #	775108
TORX®	S2 L-Handle
T10	774691
T15	774692
T20	774693
T25	774694
T27	774695
T30	774696
T40	774697
T45	774698
T50	774699



## HEX KEY WRENCHES - OPEN STOCK

Set #	775165	775164 775173	775175 775176	775104
S.A.E.	Long Arm	CrV Long Ball Nose	S2 Extra Long Ball Nose	S2 L-Handle
0.05"		774905	775005	
1/16"	774806	774906	775006	
5/64"	774807	774907	775007	774607
3/32"	774808	774908	775008	774608
7/64"	774809	774909	775009	
1/8"	774810	774910	775010	774610
9/64"	774811	774911	775011	
5/32"	774812	774912	775012	774612
3/16"	774813	774913	775013	774613
7/32"	774814	774914	775014	774614
1/4"	774815	774915	775015	774615
5/16"	774817	774917	775017	774617
3/8"	774819	774919	775019	774619
1/2"			775021	
9/16"			775022	
5/8"			775023	
3/4"			775025	

Set #	775165	775164 775184	775185 775186	775106
Metric	Short Arm	CrV Long Ball Nose	S2 Extra Long Ball Nose	S2 L-Handle
1.3mm			775054	
1.5mm	774756	774956	775056	
2.0mm	774757	774957	775057	774657
2.5mm	774758	774958	775058	774658
3.0mm	774759	774959	775059	774659
3.5mm			775060	
4.0mm	774760	774960	775061	774660
4.5mm	774761			
5.0mm	774762	774962	775063	774662
5.5mm	774763		775064	774663
6.0mm	774764	774964	775065	774664
7.0mm	774765		775067	
8.0mm	774766	774966	775069	774666
9.0mm	774767			
10.0mm	774768	774968	775073	774668
12.0mm			775075	
14.0mm			775077	
17.0mm			775080	
19.0mm			775082	

TORX® is a registered trademark of Acument Intellectual Properties, LLC.



# Torque Wrenches



HEAVY DUTY  
SUPER HEAVY DUTY  
DIGITAL  
MULTIPLIERS  
SCREWDRIVER



718912



719069

Bubble magnifier analogue scale

## TORQUE WRENCHES

### JTW Series

- 24 tooth Chrome Vanadium ratchet gear (Chrome Molybdenum on 3/4" model)
- Reversible ratchet
- Dual ft/lbs and Nm scales
- Patented lock ring
- Comfortable ergonomic handle grip
- Complete with protective blow mould case
- Perceptible jolt and audible click to indicate desired setting has been reached
- All models are factory calibrated to +/-4% with certificate and meet ISO 6789 - 1992, ANSI specifications, BSEN 26789-1994 and U.S. Government Federal Specifications GGG-W-00686C

PROD. NO.	MOD. NO.	Drive	Torque Range	Length
<b>718902</b>	JTW-1425	<b>1/4"</b>	<b>40-250 in/lbs</b> (6-30Nm)	13-3/4"
<b>718908</b>	JTW-3880	<b>3/8"</b>	<b>15-80 ft/lbs</b> (19-110Nm)	15-1/4"
<b>718911</b>	JTW-12150	<b>1/2"</b>	<b>30-150 ft/lbs</b> (40-210Nm)	21"
<b>718912</b>	JTW-12250	<b>1/2"</b>	<b>50-250 ft/lbs</b> (70-350Nm)	25-1/2"
<b>718918</b>	JTW-34600	<b>3/4"</b>	<b>100-600 ft/lbs</b> (140-700Nm)	43"
<b>718922</b>	JTW-10700	<b>1"</b>	<b>135-700 ft/lbs</b> (135-949Nm)	48"



### JMTW Slim Head Series - Heavy Duty

- Easy to use micrometer adjustment with locking nut or button
- Reversible ratchet
- Perceptible jolt and audible click to indicate desired setting has been reached
- Clearly visible analogue scale with exclusive bubble magnifier
- Patented lock button in the handle
- May be used on left and right hand threads simply by pushing the drive plug through the wrench
- Built tough for demanding professionals
- Factory calibrated to +/-4%
- Meets US Government Federal specification GGG-W-00686C

PROD. NO.	MOD. NO.	Drive	Torque Range	Length
<b>718906</b>	JMTW-3800	<b>3/8"</b>	<b>10-80 ft/lbs</b> (10-100 Nm)	16"
<b>719069</b>	JMTW-5250	<b>1/2"</b>	<b>30-250 ft/lbs</b> (30-340Nm)	24"

JET offers certified re-calibration service on torque wrenches

# TORQUE WRENCHES



## JMTW-HD Series - Heavy Duty

- Extra heavy duty Chrome Vanadium ratchet gear
- Reversible ratchet
- Magnified scale window with dual ft/lbs and Nm scales
- Push-through drive anvil allows use on left hand threads
- Patented lock ring is easy to turn even at high torque settings
- Large, comfortable ergonomic handle grip
- Complete with protective blow mould case
- Perceptible jolt and audible click to indicate desired setting has been reached
- Tension spring made in Germany for precise repeatability and long service life
- All models are factory calibrated to +/-4% with certificate and meet ISO 6789 - 1992, ANSI specifications, BSEN 26789-1994 and U.S. Government Federal Specifications GGG-W-00686C

PROD. NO.	MOD. NO.	Drive	Torque Range	Length
<b>718903</b>	JMTW-1425	<b>1/4"</b>	<b>50-250 in/lbs</b>	12"
<b>718909</b>	JMTW-3875	<b>3/8"</b>	<b>15-75 ft/lbs</b>	16-1/2"
<b>718913</b>	JMTW-12150	<b>1/2"</b>	<b>30-150 ft/lbs</b>	21"
<b>718914</b>	JMTW-12230	<b>1/2"</b>	<b>50-230 ft/lbs</b>	25-1/2"



## JPTW Series - Heavy Duty

- Measures torque in both directions with just a flip of the direction lever - no need to push anvil through wrench
- Reversible ratchet
- 32 tooth configuration requires just 11.5° swing room
- Pull-down locking ring above handle grip securely holds set torque value
- Quick release ratchet holds sockets on until released
- Permanently etched scale will not fade or wear off
- Rubber over-moulded handle for safe, secure grip
- Reinforced pawl blocks for maximum strength
- Accurate to 4% CW, 6% CCW
- All models are factory calibrated with certificate and meet ISO 6789 - 1992, ANSI specifications, BSEN 26789-1994 and U.S. Government Federal Specifications GGG-W-00686C

PROD. NO.	MOD. NO.	Drive	Torque Range	Length
<b>718933</b>	JPTW-38100	<b>3/8"</b>	<b>20 - 100 ft/lbs</b>	18-1/2"
<b>718936</b>	JPTW-12250	<b>1/2"</b>	<b>50 - 250 ft/lbs</b>	22"

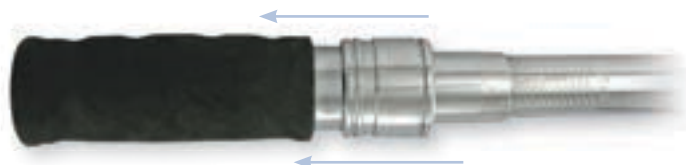

Convenient pull-down locking ring

Comfortable triangular handle grip



Quick release head

JET offers certified re-calibration service on torque wrenches



Quick release head



## TORQUE WRENCHES

### JSHD Series - Super Heavy Duty

- Magnified view window shows torque value in numbers only - no scale lines to read!
- Highest quality Japanese spring resists fatigue for long service life
- Patented dual roller reaction bar system minimizes friction for increased accuracy
- Hardened steel tube will not deflect under strain and will not be scratched by internal parts, ensuring reduced friction and highest possible accuracy
- Conversion scale permanently etched into tube for easy conversion to Nm
- Patented positive lock prevents accidental adjustment of torque value
- Quick release ratchet holds sockets on until released
- Sure grip handle with finger groove ensures correct placement of hand for better accuracy
- 48 tooth quick release reversible ratchet head - our best!
- Drop forged Chrome Molybdenum ratchet pawls for maximum strength
- Lifetime tested to a minimum of 3 x ISO standards

PROD. NO.	MOD. NO.	Drive	Torque Range	Length
<b>718952</b>	JSHD-14250	<b>1/4"</b>	<b>50 - 250 in/lbs</b>	12-3/4"
<b>718956</b>	JSHD-3875	<b>3/8"</b>	<b>15 - 75 ft/lbs</b>	15-3/4"
<b>718961</b>	JSHD-12150	<b>1/2"</b>	<b>30 - 150 ft/lbs</b>	20-3/8"
<b>718962</b>	JSHD-12250	<b>1/2"</b>	<b>50 - 250 ft/lbs</b>	24-1/2"



### Torque Screwdriver

- 1/4" drive screwdriver can be used with 1/4" hex bits or 1/4" drive sockets
- 10 - 50 in/lbs torque range
- Complete with assortment of 20 popular bits
- Comes in handy blow mould case

PROD. NO.	MOD. NO.	Drive	Torque Range	Length
<b>718991</b>	JTSD-1450K	<b>1/4"</b>	<b>10 - 50 in/lbs</b>	6"



JET offers certified re-calibration service on torque wrenches



### Digital Torque Wrenches

- Digital readout signals torque audibly and visually
- 12 multi coloured lights with beeper signal torque even when display cannot be read
- Measures torque in both directions
- Accurate to +/-2% CW, +/-3% CCW from 20% - 100% of scale
- Quickly converts between in/lbs, ft/lbs, cm/kg, and Nm scales
- Stores up to 9 torque values for quick access to commonly used settings
- Display tracks torque as it is applied or can be set to display peak torque
- Records up to 50 Peak Hold values for accurate record keeping
- Large handle features soft touch TPR grip for user comfort
- Industrial quality 36 tooth sealed ratchet head
- Simple intuitive menu
- Meets ISO 6789-1992 and ANSI standards
- Blow mould case

PROD. NO.	MOD. NO.	Drive	Torque Range	Length
718941	JDTW-14250	1/4"	13.3 - 265.5 in/lbs 1.5 - 30Nm	15-11/32"
718943	JDTW-38100	3/8"	5 - 99.5 ft/lbs 6.8 - 135Nm	16-5/16"
718946	JDTW-12250	1/2"	12.5 - 250.5 ft/lbs 17 - 340Nm	25-1/2"



LED lights signal torque

Simple intuitive menu

718946

JET offers certified re-calibration service on torque wrenches



Reaction base and 90° reaction bar



## TORQUE MULTIPLIERS - HEAVY DUTY

▼ *Hand Tools shown in this section feature:*

- Used to multiply applied force for setting and removing high torque fasteners
- Planetary gear system multiplies input force many times
- Torque multipliers lower physical effort, resulting in smooth, steady application of torque and increased accuracy
- Permits application of high torque without use of a long lever
- Can be driven with a torque wrench
- Kit includes straight and 90° reaction bars with reaction base (base not included in **719071** kit)
- 90° bar and base rests against truck wheel rims when used to torque lug nuts
- 1/2" drive models available with 3.3:1, 6.5:1 and 12:1 torque ratios
- Higher ratios require lower input forces, reducing operator effort
- All models include breakaway input adaptor to protect wrench from overload

### JTM Series Kits

PROD. NO.	MOD. NO.	Input Drive	Output Drive	Gear Ratio	Torque Ratio	Max. Input	Max. Output
<b>719071</b>	JTM-50750	1/2"	3/4"	4:1	3.3:1	227 ft/lbs	750 ft/lbs
<b>719072</b>	JTM-51100	1/2"	3/4"	9:1	6.5:1	170 ft/lbs	1,100 ft/lbs
<b>719074</b>	JTM-51850	1/2"	1"	16:1	12:01	154 ft/lbs	1,850 ft/lbs
<b>719075</b>	JTM-71850	3/4"	1"	4:1	3.3:1	560 ft/lbs	1,850 ft/lbs



**WARNING:** Do not use impact tools with torque multipliers. Serious damage or injury could occur.



719071



719075





**Screwdrivers  
Bits  
Nut Drivers**

- SCREWDRIVERS
- RATCHETING DRIVERS
- IMPACT DRIVER
- NUT DRIVERS
- INSERT BITS
- POWER BITS



720505



720956



720574



720507

**WARNING:** Insulated handles rated for use to 220V only. Do not use on higher voltage circuits. Not for use on live circuits

## JUMBO HANDLE SERIES - SETS

- Jumbo grip grooved handle design ensures maximum torque for tough jobs
- Made with super acetates these handles are virtually indestructible
- Shafts made of the highest quality Chrome Vanadium steel for long life and maximum durability
- Black hardened magnetic tips eliminate chrome plating chipping off the tip (common on other brands), holds the screw to the screwdriver and ensures maximum durability and life
- All items meet ANSI Specifications, U.S. Specifications GGG-S-121E and Canadian Government specifications CDA39-GP-17C

### 6 PC Basic Set

720505 / JHSS-6

Slot

Phillips

Square

1/4 x 4"  
5/16 x 6"#1 x 3"  
#2 x 4"#1 x 4"  
#2 x 5"

- Handy storage rack



### 6 PC TORX® Set

720956 / JHTSS-6

TORX®

T10 x 4", T15 x 4", T20 x 4", T25 x 4", T27 x 4", T30 x 4"

- Terylene Pouch



### 13 PC Mechanic's Set

720574 / JHMSS-13

Slot

Phillips

TORX®

1/4 x 1-1/2"  
1/4 x 4"  
5/16 x 6"  
3/8 x 10"#1 x 3"  
#2 x 1-1/2"  
#2 x 4"T10 x 4"  
T15 x 4"  
T20 x 4"  
T25 x 4"  
T27 x 4"  
T30 x 4"

- Supplied in convenient blow mould tool tray



### 14 PC Master Set

720507 / JHSS-14

Phillips

Square

Slot Square Shaft

Slot Round Shaft

#2 x 1-1/2"  
#1 x 3"  
#2 x 4"  
#3 x 6"#2 x 1-1/2"  
#1 x 4"  
#2 x 5"  
#3 x 6"1/4 x 1-1/2"  
1/4 x 4"  
5/16 x 6"  
3/8 x 10"3/16 x 3"  
3/16 x 6"

- Supplied in convenient blow mould tool tray



## Slot - Square Shank

PROD. NO.	MOD. NO.	Size
<b>720354</b>	SDS-4S	1/4 x 4"
<b>720356</b>	SDS-6S	5/16 x 6"
<b>720360</b>	SDS-10S	3/8 x 10"
<b>720362</b>	SDS-12S	3/8 x 12"
<b>720392</b>	SDS-2SS	1/4 x 1-1/2" (Stubby)



## Slot - Round Shank

PROD. NO.	MOD. NO.	Size
<b>720363</b>	SDS-3R	3/16 x 3"
<b>720366</b>	SDS-6R	3/16 x 6"



## Phillips - Round Shank

PROD. NO.	MOD. NO.	Size
<b>720371</b>	SDP-1	#1 x 3"
<b>720372</b>	SDP-2	#2 x 4"
<b>720373</b>	SDP-3	#3 x 6"
<b>720382</b>	SDP-2S	#2 x 1-1/2" (Stubby)



## Square - Round Shank

PROD. NO.	MOD. NO.	Size
<b>721361</b>	SDR-1	#1 x 4"
<b>721362</b>	SDR-2	#2 x 5"
<b>721363</b>	SDR-3	#3 x 6"
<b>721372</b>	SDR-2S	#2 x 1-1/2" (Stubby)



## TORX® - Round Shank

PROD. NO.	MOD. NO.	Size
<b>720911</b>	SDT-10	T10 x 4"
<b>720917</b>	SDT-15	T15 x 4"
<b>720922</b>	SDT-20	T20 x 4"
<b>720925</b>	SDT-25	T25 x 4"
<b>720929</b>	SDT-27	T27 x 4"
<b>720932</b>	SDT-30	T30 x 4"

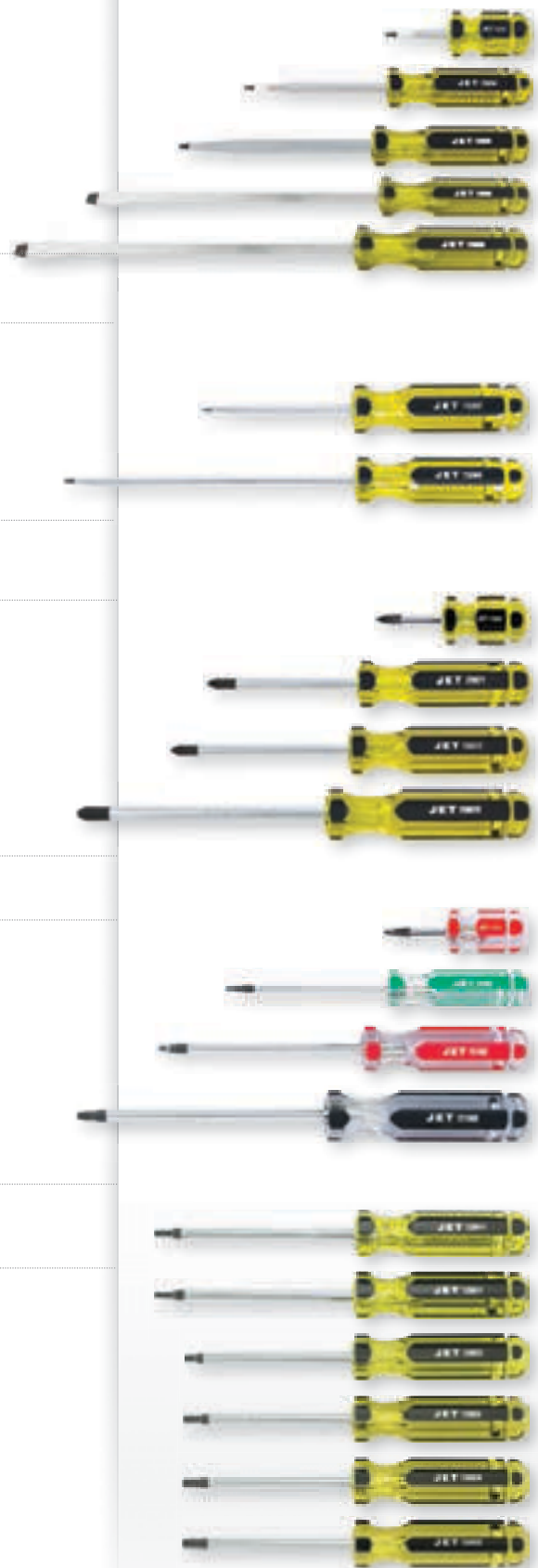

TORX® is a registered trademark of Acument Intellectual Properties LLC.



## TORQUE DRIVE®



720508

## TORQUE DRIVE® SERIES - SETS

### ▼ Hand Tools shown in this section feature:

- JET's exclusive TORQUE DRIVE® cushion grip ergonomic handle design guarantees maximum torque and unparalleled user comfort increasing performance and productivity
- Black hardened magnetic tips eliminate chrome plating chipping off the tip (common on other brands), holds the screw to the screwdriver and ensures maximum durability and life
- Shafts made of the highest quality Chrome Vanadium steel for long life and maximum durability
- "Go thru" design offers a one piece metal shaft from handle to tip
- All items meet U.S. Specifications GGG-S-121E and Canadian Government specifications CDA39-GP-17C

### 6 PC Basic Set

720508 / TDSS-6

Slot Phillips Square 1/4 x 4"  
5/16 x 6"#1 x 4"  
#2 x 4"#1 x 4"  
#2 x 4"

CrV



# TORQUE DRIVE® SERIES - OPEN STOCK



▼ Hand Tools shown in this section feature:

- JET's exclusive TORQUE DRIVE® cushion grip ergonomic handle design guarantees maximum torque and unparalleled user comfort increasing performance and productivity
- Black hardened magnetic tips eliminate chrome plating chipping off the tip, holds the screw to the screwdriver and ensures maximum durability and life
- Shafts made of the highest quality Chrome Vanadium steel for long life and maximum durability
- "Go thru" design offers a one piece metal shaft from handle to tip
- All items meet U.S. Specifications GGG-S-121E and Canadian Government specifications CDA39-GP-17C

## TORQUE DRIVE®



### Slot - Round Shank

PROD. NO.	MOD. NO.	Size
720404	TDS-4	1/4 x 4"
720406	TDS-6	5/16 x 6"
720444	TDS-4N	3/16 x 4"
720446	TDS-6N	3/16 x 6"



### Phillips - Round Shank

PROD. NO.	MOD. NO.	Size
720421	TDS-1P	#1 x 4"
720422	TDS-2P	#2 x 4"
720423	TDS-3P	#3 x 6"



### Square - Round Shank

PROD. NO.	MOD. NO.	Size
720431	TDS-1R	#1 x 4"
720432	TDS-2R	#2 x 4"
720433	TDS-3R	#3 x 6"



**NEW**

720523



720524



720527

## ERGONOMIC SCREWDRIVERS - SETS

### ▼ Hand Tools shown in this section feature:

- Unique handle design conforms to the hand for exceptional comfort and grip
- Co-moulded Polypropylene (PP) and Thermoplastic Vulcanizates (TPV) ensure maximum strength balanced with superior non-slip grip
- Resistant to most chemicals, solvents, and oil
- Pentagon shaped neck bolster minimizes roll away
- Tip size and style on handle end for easy identification in tool pouch
- Patented SVCM tool steel is up to 30% stronger than CRV screwdrivers
- Phosphate plated tip will not chip or peel
- Meets ANSI specifications

### 9 PC Ergonomic Screwdriver Set

720523 / JSTD-9S

Slot

Phillips

Square

3/16 x 3"  
1/4 x 4"  
5/16 x 6"

#1 x 3"  
#2 x 4"  
#3 x 6"

#1 x 4"  
#2 x 4"  
#3 x 4"

SVCM



### 14 PC Ergonomic Screwdriver Set

720524 / JSTD-14S

Slot

Phillips

Square

3/16 x 3"  
3/16 x 6"  
1/4 x 1-1/2"  
1/4 x 4"  
5/16 x 6"  
3/8 x 8"

#1 x 3"  
#2 x 1-1/2"  
#2 x 4"  
#3 x 6"

#1 x 4"  
#2 x 1-1/2"  
#2 x 4"  
#3 x 4"

SVCM



### 7 PC Ergonomic TORX® Driver Set

720527 / JTSD-7TS

TORX®

T10 x 4", T15 x 4", T20 x 4", T25 x 4", T27 x 4", T30 x 4", T40 x 4"

SVCM





## Ergonomic Screwdrivers

**NEW**

PROD. NO.	MOD. NO.	Description
720812	JTCS-3	3/16 x 3" Cabinet Tip Slot Ergonomic Screwdriver
720813	JTCS-6	3/16 x 6" Cabinet Tip Slot Ergonomic Screwdriver
720814	JTSS-2	1/4 x 1-1/2" Keystone Tip Slot Ergonomic Screwdriver
720815	JTSS-4	1/4 x 4" Keystone Tip Slot Ergonomic Screwdriver
720817	JTSS-6	5/16 x 6" Keystone Tip Slot Ergonomic Screwdriver
720818	JTSS-8	3/8 x 8" Keystone Tip Slot Ergonomic Screwdriver
720821	JTPH-1	#1 x 3" Phillips Ergonomic Screwdriver
720823	JTPH-2S	#2 x 1-1/2" Phillips Ergonomic Screwdriver
720824	JTPH-2	#2 x 4" Phillips Ergonomic Screwdriver
720827	JTPH-3	#3 x 6" Phillips Ergonomic Screwdriver
720832	JTSR-1	#1 x 4" Square Ergonomic Screwdriver
720834	JTSR-2S	#2 x 1-1/2" Square Ergonomic Screwdriver
720835	JTSR-2	#2 x 4" Square Ergonomic Screwdriver
720837	JTSR-3	#3 x 4" Square Ergonomic Screwdriver



## TORX® Ergonomic Screwdrivers

PROD. NO.	MOD. NO.	Description
720841	JTST-10	T10 x 4" TORX® Ergonomic Screwdriver
720842	JTST-15	T15 x 4" TORX® Ergonomic Screwdriver
720843	JTST-20	T20 x 4" TORX® Ergonomic Screwdriver
720844	JTST-25	T25 x 4" TORX® Ergonomic Screwdriver
720845	JTST-27	T27 x 4" TORX® Ergonomic Screwdriver
720846	JTST-30	T30 x 4" TORX® Ergonomic Screwdriver
720848	JTST-40	T40 x 4" TORX® Ergonomic Screwdriver



720812



720823



720835

**NEW**



720844



TORX® is a registered trademark of Acument Intellectual Properties LLC.



## CUSHION GRIP SCREWDRIVER - SETS

### ▼ Hand Tools in this section feature:

- Patented SVCM tool steel is up to 30% stronger than CrV screwdrivers
- Hardened and tempered for superior strength and improved durability
- Super strong acetate handles resist impact and chemicals
- Integrated cushion grips provide all day comfort and increased torque
- Chrome plated for superior corrosion resistance
- Precision machined blackened tips for superior fit in all screw head types
- Tip type permanently engraved on handle ends for easy identification in tool pouch



720560

### 4 PC Cushion Grip Mini Screwdriver Set

720560 / JKS-4SM

Slot - Round Shank

Phillips

1/16" x 3"  
3/32" x 3"  
1/8" x 3"

#0 x 3"

SVCM



720562

### 4 PC Extra Long Cushion Grip Screwdriver Set

720562 / JKS-4SL

Slot - Round Shank

Phillips

Square

3/8" x 10"  
3/8" x 12"

#2 x 10"

#2 x 8"

SVCM



720564

### 9 PC Cushion Grip Screwdriver Set

720564 / JKS-9S

Slot - Square Shank

Phillips

Square

3/16" x 3"  
1/4" x 4"  
5/16" x 6"

#1 x 3"  
#2 x 4"  
#3 x 6"

#1 x 4"  
#2 x 4"  
#3 x 4"

SVCM



720566

### 14 PC Cushion Grip Screwdriver Set

720566 / JKS-14S

Slot - Square Shank

Slot Stubby Round Shank

Cabinet Tip

Phillips

Square

1/4" x 4"  
5/16" x 6"  
3/8" x 8"

1/4" x 1-1/2"

3/16" x 3"  
3/16" x 6"

#1 x 3"  
#2 x 1-1/2"  
#2 x 4"  
#3 x 6"

#1 x 4"  
#2 x 1-1/2"  
#2 x 4"  
#3 x 4"

SVCM



# CUSHION GRIP SCREWDRIVERS - OPEN STOCK



## Miniature - Slot/Phillips - Round Shank

PROD. NO.	MOD. NO.	Size
720605	JKMS-116	1/16" x 3"
720606	JKMS-332	3/32" x 3"
720607	JKMS-18	1/8" x 3"
720641	JKMP-0	PH#0 x 3"



SVCM



## Slot - Square Shank

720612	JKSS-4	1/4" x 4"
720613	JKSS-6	5/16" x 6"
720616	JKSS-8	3/8" x 8"



SVCM



## Slot - Round Shank

720621	JKSS-2RS	1/4" x 1-1/2"
720622	JKSS-4R	1/4" x 4"
720623	JKSS-6R	5/16" x 6"
720626	JKSS-8R	3/8" x 8"
720627	JKSS-10R	3/8" x 10"
720628	JKSS-12R	3/8" x 12"



SVCM

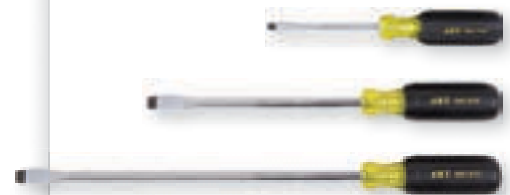

## Cabinet Tip - Round Shank

720632	JKSS-3CT	3/16" x 3"
720633	JKSS-4CT	3/16" x 4"
720634	JKSS-6CT	3/16" x 6"
720635	JKSS-8CT	3/16" x 8"



SVCM



## Phillips - Round Shank

720642	JKSP-1	PH1 x 3"
720644	JKSP-2S	PH2 x 1-1/2"
720646	JKSP-2	PH2 x 4"
720648	JKSP-2L	PH2 x 10"
720649	JKSP-3	PH3 x 6"



SVCM



## Square - Round Shank

720653	JKSR-1	R1 x 4"
720654	JKSR-2S	R2 x 1-1/2"
720656	JKSR-2	R2 x 4"
720658	JKSR-2L	R2 x 8"
720659	JKSR-3	R3 x 4"



SVCM





REPLACEMENTS BITS  
SEE PAGE 349



**Distributors**  
**please note:** Drivers  
are sold in 6 pack  
P.O.P. display only

## CUSHION GRIP MULTI-BIT DRIVERS - SETS

- Super strong acetate handle resists impact and chemicals
- Integrated cushion grip provides all day comfort and increased torque
- Chrome plated for superior corrosion resistance
- Double ended bits for maximum versatility with minimal pieces
- Can be used as a nut driver with bits removed

### 5-in-1 Cushion Grip Multi-Bit Screwdriver

720531 / JKMD-5S

Slot 	Phillips 	Square 	Nut 
3/16 & 1/4"	#2	#2	1/4"

### 6-in-1 Cushion Grip Multi-Bit Screwdriver

720533 / JKMD-6

Slot 	Phillips 	Square 	Nut 
3/16 & 1/4"	#2	#2	1/4" & 5/16"

### 10-in-1 Cushion Grip Multi-Bit Screwdriver

720534 / JKMD-10

Slot 	Phillips 	Square 	Nut 
3/16 & 1/4"	#1, #2, #3	#1, #2, #3	1/4" & 5/16"

## MULTI-BIT DRIVERS - SETS

### 15-In-1 Multi-Bit Screwdriver

H3400

- Features a patented pullout bit cartridge
- 15-in-1 multi-bit screwdriver replaces 14 of the most popular bits and 14 screwdrivers and a 1/4" hex nut drive
- 2" double end bits are made of superior quality S2 steel for strength and durability
- Shaft is made of super high strength 12T14 steel for long life
- End of shaft is a 1/4" hex nut driver
- Handle is made of durable nylon reinforced Triax® resin for longest life
- Unique rotating cap design allows you to position the cap in the palm of your hand and rotate the driver handle with your fingers. The driver then acts like a gearless ratcheting screwdriver increasing productivity while reducing blisters and operator fatigue
- Drivers are easy to use from both the left and right sides allowing you to use them in tight confined areas
- Collar also swivels 360° for fast efficient driving of screws
- Made in the U.S.A



# RATCHETING DRIVERS

- 19-in-1 screwdriver features 8 double-ended bits and 3 nut driver sizes
- Heavy duty reversible 25 tooth ratchet with centre lock position
- Ergonomic handle for comfort and secure grip
- Bits store in handle



REPLACEMENTS BITS  
SEE PAGE 349

## 19-in-1 Multi-Bit Screwdriver 720590 / JRSD-19

- Available in 12 piece POP display



**8 1/4" Double-Ended Bits**

1/8" & #0	S1 & S2
3/16" & #1	T-10 & T-15
1/4" & #2	T-20 & T-25
5/16" & #3	1/8" & 3/16"

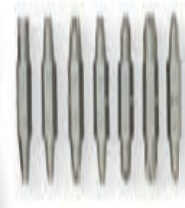

## 38 PC Set 720591 / JRSD-38

- 1/4" Drive Sockets:  
**3/16", 7/32", 1/4", 9/32", 5/16", 11/32", 3/8", 7/16", 1/2"**  
**5, 6, 7, 8, 9, 10, 11, 12, 13mm**
- 1/4" Drive sockets adaptor
- Blow Mould Case



Bit storage cartridge concealed in handle



**BIT LOAD**  
**1/8", 3/16", 1/4" Slot**  
**PH1, PH2, PH3 Phillips**  
**R1, R2, R3 Square**  
**T10, T15, T20, T25 TORX®**  
**1/4" Nut Driver**

## Twin Drive Ratcheting Screwdriver 720537 / JTDS-15S

- Unique twin ratcheting system provides high torque or high speed driving
- Changing how you grip the screwdriver automatically switches between high torque with ratcheting action or low torque with 3:1 turning ratio for greater speed when turning long screws
- Use with one hand as a regular screwdriver and the ratchet allows you to reverse without disengaging the screw while providing maximum torque
- Ergonomic handle with non-slip materials for maximum grip
- Available in 6 piece POP display



**3x**

**1x**

Hold the transmission collar and the screw bit is driven 3 turns for every 1 turn of the handle



Bits



Shafts



BIT LOAD

**5.5, 6.5mm Slot****#1, #2 Phillips****#1, #2 Square****1/4" Socket Adaptor**

Bit storage cartridge concealed in handle

## RATCHETING DRIVERS

- 45 tooth all steel ratchet mechanism provides high torque and smooth operation
- Lifetime tested to 50,000 cycles
- Soft textured handle provides excellent grip
- Chrome Vanadium steel shaft with powerful bit holder magnet

### Convertible Pistol Grip Ratcheting Screwdriver

**720551 / JPRSD-9**

- Spring loaded cartridge in handle pops out with a simple squeeze of the recessed buttons and holds 6 bits on board
- Complete with 6 nickel plated S2 bits and 1/4" socket drive adaptor
- Can be used with any 1/4" hex drive bits for easy customizing of bit load
- Available in 12 piece POP display
- Replacement Bit Cartridge (**720559**)



3 position switch for left and right ratcheting or non-ratcheting use



Unique 2-way handle converts from straight to pistol grip for increased torque



# RATCHETING DRIVERS



## Stubby Ratcheting Screwdriver

720552 / JRSD-9S

- Stubby handle for work in confined spaces
- 3 position switch for left and right ratcheting or non-ratcheting use
- Complete with 6 nickel plated S2 bits and 1/4" socket drive adaptor
- Can be used with any 1/4" hex drive bits for easy customizing of bit load
- Available in 12 piece POP display



BIT LOAD

5.5, 6.5mm slot  
 #1 #2 Phillips  
 #1 #2 Square  
 1/4" socket adaptor



Complete with 6 nickel plated S2 bits and 1/4" socket drive adaptor



Bits



Shafts

Stubby handle for work in confined spaces



3 position switch for left and right ratcheting or non-ratcheting use



Bits



Shafts

Comfortable T-Handle provides excellent grip and transfer of power



3 position switch for left and right ratcheting or non-ratcheting use



BIT LOAD

4.0, 5.5, 6.5mm slot  
 #1, #2, #3 Phillips  
 #1, #2, #3 Square  
 T10, T15, T20, T25, T27 TORX®  
 3, 4, 5mm Hex  
 1/4" Socket Adaptor

## T-Handle Ratcheting Screwdriver

720556 / JTRSD-21

- Includes interchangeable 2" and 4" shafts for added versatility
- Can be used with any 1/4" hex drive bits for easy customizing of bit load
- Available in 12 piece POP display

Complete with 17 nickel plated S2 bits and 1/4" socket drive adaptor



Available in various package quantities to suit any need



## INSERT BITS

▼ *Hand Tools in this section feature:*

- A2 Steel bits are dual heat treated for greatly increased tensile strength
- Allows for more consistent edges and up to 50% greater life than S2 bits
- Heat treated to HRC 58-62
- 1" overall length
- For use with standard or quick release 1/4" hex bit holders
- Canada's strongest and longest lasting bits

### Slot

PROD. NO.	Tip Size	Length	Pieces
729112	5/32"	1"	2
729114	5/32"	1"	20
729119	1/4"	1"	2
729121	1/4"	1"	20

A<sub>2</sub>

### Phillips

729009	PH1	1"	2
729011		1"	20
729025		1"	2
729027	PH2	1"	20
729028		1"	50
729042	PH3	1"	2
729044		1"	20

A<sub>2</sub>

### Square

729061	R1	1"	2
729063		1"	20
729078		1"	2
729080	R2	1"	20
729081		1"	50
729095	R3	1"	2
729097		1"	20

A<sub>2</sub>

## TORX®

PROD. NO.	Tip Size	Length	Pieces
729163	T8	1"	2
729166	T10	1"	2
729173	T15	1"	2
729180	T20	1"	2
729187	T25	1"	2
729194	T27	1"	2
729201	T30	1"	2
729208	T40	1"	2

A<sub>2</sub>

## Hex

PROD. NO.	Tip Size	Length	Pieces
729303	1/8"	1"	2
729317	5/32"	1"	2
729324	3/16"	1"	2
729331	7/32"	1"	2
729338	1/4"	1"	2
729366	3mm	1"	2
729373	4mm	1"	2
729380	5mm	1"	2
729394	6mm	1"	2

A<sub>2</sub>

## Magnetic Bit Holders

- For use with insert bits or to extend the reach of power bits
- Powerful magnet holds bit in any position
- Quick release model locks bit in place until ejected

PROD. NO.	MOD. NO.	Type
729483	JMBH-60	Magnetic
729484	JQBH-65	Quick Release Magnetic

A<sub>2</sub>



# POWER BITS



- A2 Steel bits are dual heat treated for greatly increased tensile strength
- Allows for more consistent edges and up to 50% greater life than S2 bits
- Heat treated to HRC 58-62
- Available in various package quantities and lengths to suit any need
- 1/4" hex shaft fits ball retainer and regular style chucks
- Canada's strongest and longest lasting bits



## Slot

PROD. NO.	Tip Size	Length	Pieces
729115	5/32"	2"	2
729117	5/32"	2"	10
729122	1/4"	2"	2
729124	1/4"	2"	10



## Phillips

PROD. NO.	Tip Size	Length	Pieces
729013		2"	2
729015		2"	10
729018	PH1	2-3/4"	2
729020		2-3/4"	10
729022		6"	1
729029		2"	2
729031		2"	10
729032		2"	25
729034	PH2	2-3/4"	2
729036		2-3/4"	10
729039		6"	1
729040		6"	10
729046		2"	2
729048		2"	10
729051	PH3	2-3/4"	2
729056		6"	1



## Square

PROD. NO.	Tip Size	Length	Pieces
729065		2"	2
729067		2"	10
729070	R1	2-3/4"	2
729072		2-3/4"	10
729075		6"	1
729082		2"	2
729084		2"	10
729085		2"	25
729087	R2	2-3/4"	2
729089		2-3/4"	10
729092		6"	1
729093		6"	10
729099		2"	2
729101		2"	10
729104	R3	2-3/4"	2
729109		6"	1



## Hex

729306	1/8"	2"	2
729320	5/32"	2"	2
729327	3/16"	2"	2
729334	7/32"	2"	2
729341	1/4"	2"	2
729369	3mm	2"	2
729376	4mm	2"	2
729383	5mm	2"	2
729397	6mm	2"	2



# NUTSETTERS

- Powerful magnet holds fastener securely for use in any position
- Heat treated Chrome Vanadium steel for professional use
- 1/4" hex shaft fits ball retainer and regular style chucks



## TORX®

729169	T10	2"	2
729176	T15	2"	2
729183	T20	2"	2
729190	T25	2"	2
729197	T27	2"	2
729204	T30	2"	2
729211	T40	2"	2



## S.A.E. CrV Steel

PROD. NO.	Size	Pieces
729461	1/4"	1
729462	5/16"	1
729463	3/8"	1



## Metric CrV Steel

PROD. NO.	Size	Pieces
729471	6mm	1
729472	7mm	1
729473	8mm	1
729475	10mm	1





Hollow shafts allow running nuts on long fasteners



## CUSHION GRIP NUT DRIVERS - SETS

▼ *Hand Tools in this section feature:*

- Chrome Vanadium steel for professional use
- Hardened and tempered for superior strength and improved durability
- Super strong acetate handles resist impact and chemicals
- Integrated cushion grips provide all day comfort and increased torque
- Chrome plated for superior corrosion resistance
- Hex bolster allows use of a wrench for increased torque
- Hollow shaft fits over long fasteners
- Socket size permanently embossed on handles for easy identification in tool pouch
- Convenient plastic carrying case keeps nut drivers organized

### 7 PC S.A.E. Cushion Grip Nut Driver Set

721101 / JKND-7S

3/16", 1/4", 5/16", 11/32", 3/8", 7/16", 1/2"



### 7 PC Metric Cushion Grip Nut Driver Set

721102 / JKND-7M

6, 7, 8, 9, 10, 11, 12mm



## CUSHION GRIP NUT DRIVERS - OPEN STOCK

### S.A.E.

### Metric

PROD. NO.	Size	PROD. NO.	Size
721141	3/16" x 3	721151	6mm x 3
721142	1/4" x 3	721152	7mm x 3
721143	5/16" x 3	721153	8mm x 3
721144	11/32" x 3	721154	9mm x 3
721145	3/8" x 3	721155	10mm x 3
721146	7/16" x 3	721156	11mm x 3
721147	1/2" x 3	721157	12mm x 3







721111

## JUMBO HANDLE SERIES - SET

- Jumbo grip grooved handle design ensures maximum torque for tough jobs
- Made with super acetates, these handles are virtually indestructible
- Hollow shank Chrome Vanadium shafts

### 7 PC S.A.E. - Hollow Shaft

721105 / NDS-07

3/16, 1/4, 5/16, 11/32, 3/8, 7/16, 1/2"

- Roll up pouch



721105

## JUMBO HANDLE SERIES - OPEN STOCK

### S.A.E. - Hollow Shaft

PROD. NO.	MOD. NO.	Size	Length	Point
721111	ND-316	3/16"	3-1/2"	6
721112	ND-14	1/4"	3-1/2"	6
721113	ND-516	5/16"	3-1/2"	6
721114	ND-1132	11/32"	3-1/2"	6
721115	ND-38	3/8"	3-1/2"	6
721116	ND-716	7/16"	3-1/2"	6
721117	ND-12	1/2"	3-1/2"	6





## PRECISION SCREWDRIVER - SETS

- Ergonomic bi-material handles for sure grip
- Rotating cap allows easy one hand operation
- Chrome Vanadium steel shafts
- Convenient plastic case



720542



720546

### 6 PC Slot / Phillips Set

720542 / JPSP-6

Slot

Phillips

2.0, 3.0, 4.0

#00, #0, #1



### 6 PC TORX® Set

720546 / JPSP-6T

TORX®

T5, T6, T7, T8, T9, T10



## IMPACT DRIVER

1/2" Drive

720702 / JID-5S

- Premium grade high carbon steel body withstands high impact forces
- Entirely heat treated for maximum strength
- S2 steel bits for professional use
- Drives 5/16" shank screwdriver bits and 1/2" drive impact sockets
- Reversible for installing or removing fasteners
- Ideal for removing rusted fasteners
- Includes 5/16" and 3/8" slot and #2 and #3 Phillips bits



Replacement 4 piece bit set **720791**

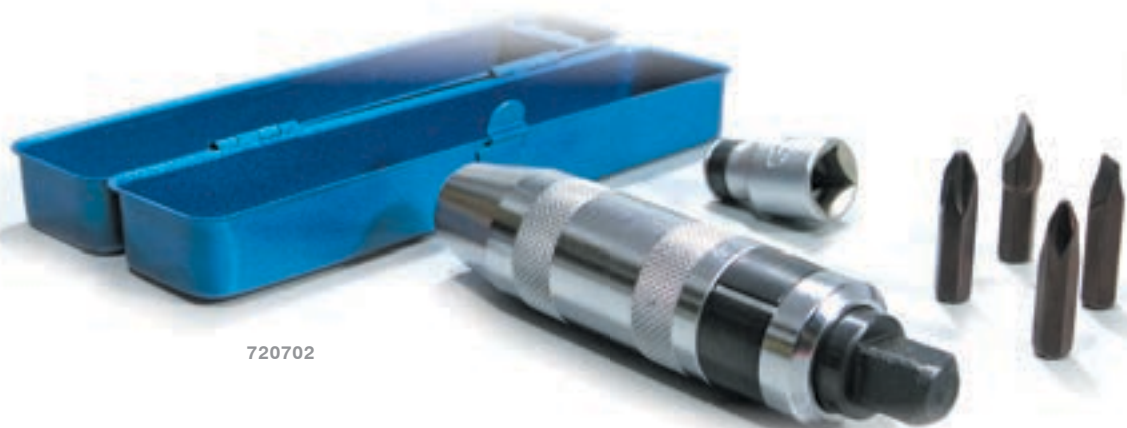

720702



**Pliers  
Cutters  
Sheet Metal  
Tools**



LOCKING PLIERS  
LONG REACH  
SNAP RING PLIERS  
WIRE STRIPPERS  
CUTTERS  
AVIATION SNIPS  
RIVET TOOLS



**NEW**



730338

## LOCKING PLIERS - SETS

- Made of Chrome Molybdenum steel for added durability
- Heat treated handles, pins and jaws
- Nickel plated finish resists corrosion
- Strong locking mechanism with welded seams for strength under load
- Ergonomic cushioned release lever is guarded to prevent accidental release
- All locking pliers come with wire cutter in jaw
- Meets ANSI requirements

### 5 PC Locking Pliers Set

PROD. NO.	MOD. NO.	Pieces	Length	Type
<b>730338</b>	JLPS-5	5	5, 7, 10" 7, 9"	Curved Jaw Long Nose

CrMo

**NEW**



Curved Jaw

### Locking Pliers - Open Stock

PROD. NO.	MOD. NO.	Length	Type
<b>730452</b>	JLP-5C	5"	Curved Jaw
<b>730454</b>	JLP-7C	7"	Curved Jaw
<b>730457</b>	JLP-10C	10"	Curved Jaw
<b>730464</b>	JLP-7L	7"	Curved Jaw
<b>730466</b>	JLP-9L	9"	Curved Jaw

CrMo

Teeth raked to provide superior non-slip grip



# LOCKING PLIERS - OPEN STOCK

- **Exclusive 9254 steel** jaw components offer increased core strength over Chrome Molybdenum or Chrome Vanadium jaws
- Jaw hardness increases below the surface allowing for increased clamping pressure and offering longer tooth life
- **Precision ground jaws** with backward raked teeth for superior grip
- All models complete with wire cutter
- Cushioned release lever is guarded to prevent accidental release
- Handles made of top quality **Chrome Molybdenum steel** – much stronger than carbon steel handles used on the leading brand
- Stronger handle steel prevents rivet holes from enlarging over time, leading to rivet failure
- Exceeds ANSI requirements and industry standards
- You can't buy a better, stronger locking pliers

Chrome Molybdenum steel handles



730453, 730455, 730458



730335

## Locking Pliers - Sets - Super Heavy Duty

PROD. NO.	MOD. NO.	Pieces	Length	Type
<b>730336</b>	LPS-3	3	<b>6", 7, 10"</b> <b>6"</b>	Curved Jaw Long Nose
<b>730335</b>	LPS-5	5	<b>5, 7, 10"</b> <b>6, 9"</b>	Curved Jaw Long Nose



**NEW**



## Locking Pliers - Open Stock

PROD. NO.	MOD. NO.	Length	Type
<b>730453</b>	J5WR	<b>5"</b>	Curved Jaw
<b>730455</b>	J7WR	<b>7"</b>	Curved Jaw
<b>730456</b>	J7WRG	<b>7"</b>	Curved Jaw / PVC Grip
<b>730458</b>	J10WR	<b>10"</b>	Curved Jaw
<b>730459</b>	J10WRG	<b>10"</b>	Curved Jaw / PVC Grip
<b>730462</b>	J4LN	<b>4"</b>	Long Nose
<b>730463</b>	J6LN	<b>6"</b>	Long Nose
<b>730467</b>	J9LN	<b>9"</b>	Long Nose



730336



PVC Grip



Long Nose



# LOCKING PLIERS - OPEN STOCK

## Chain wrench style



730496

- 20" chain
- Made of industrial quality Chrome Molybdenum steel
- Strong locking mechanism
- Precision ground jaws
- Ergonomic cushioned release lever is guarded to prevent accidental release
- Teeth raked to provide superior non-slip grip
- Meets ANSI requirements
- Quality equal to the best!

PROD. NO.	MOD. NO.	Length	Type
<b>730496</b>	J20R	<b>20"</b>	Chain Wrench



730555

## Locking Clamps - Open Stock

- Chrome Vanadium and Chrome Molybdenum jaw components for improved strength
- C-Clamps available with your choice of plain tips or swivel pads
- New heavy duty materials for improved performance and life

PROD. NO.	MOD. NO.	Length	Type
<b>730554</b>	J6R	<b>6"</b>	C-Clamp
<b>730555</b>	J6RP	<b>6"</b>	C-Clamp with Pads
<b>730556</b>	J11R	<b>11"</b>	C-Clamp
<b>730557</b>	J11RP	<b>11"</b>	C-Clamp with Pads
<b>730558</b>	J8R	<b>8"</b>	Sheet Metal
<b>730559</b>	J9R	<b>9"</b>	Welders

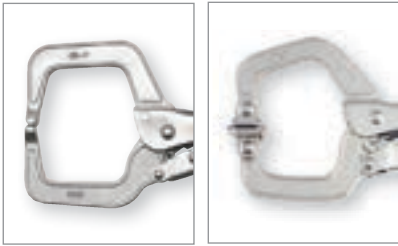

730554, 730556  
C-Clamp

730555, 730557  
C-Clamp with Pads



730558  
Sheet Metal



730559  
Welders

# SNAP RING PLIERS - SETS



- Cushion grip handles
- Made of carbon steel
- Spring loaded handles

## 5 PC Interchangeable Tip

PROD. NO.	MOD. NO.	Length	Type
<b>730352</b>	SRP-1S	6"	Straight tips, Bent tips, Convertible type



730352

## 4 PC Permanent Tip Style

PROD. NO.	MOD. NO.	Length	Type
<b>730353</b>	SRP-4S	7"	Internal Straight, External Straight, Internal Bent, External Bent



730353

# SNAP RING PLIERS - OPEN STOCK



## Internal Type

PROD. NO.	MOD. NO.	Length	Type
<b>730701</b>	SRP-175IS	7"	Internal Straight
<b>730702</b>	SRP-175IB	7"	Internal Bent

## External Type

PROD. NO.	MOD. NO.	Length	Type
<b>730703</b>	SRP-175ES	7"	External Straight
<b>730704</b>	SRP-175EB	7"	External Bent





## CHROME VANADIUM - SETS

- Made of high quality Chrome Vanadium steel (except slip joint)
- Cutting edges induction hardened to HRC58-62
- Double-dipped cushion grip handles offer superior comfort, sure gripping action and long life



730311

### 4 PC Starter Pliers Set

730311 / JPS-4N

- 6-1/2" Diagonal Cutter
- 6-1/2" Long Nose
- 7" Lineman's
- 8" Slip Joint



730321

### 5 PC Maintenance Set

730321 / JPS-5

- 8" Long Nose
- 8" Diagonal Cutter
- 8" Lineman's
- 8" Slip Joint
- 8" Bent Nose



730341

### 5 PC Mechanics Pliers Set

730341 / JPS-5M

- 8" Angle Head Cutter
- 8" Long Nose
- 8" Lineman's
- 8" Slip Joint
- 8" Groove Joint





# CHROME VANADIUM - OPEN STOCK



▼ *Hand Tools in this section feature:*

- Made of high quality Chrome Vanadium steel (except Slip Joint)
- Cutting edges induction hardened to HRC58-62
- Double-dipped cushion grip handles offer superior comfort, sure gripping action and long life

## Slip Joint Pliers

- Made of quality Carbon steel

PROD. NO.	MOD. NO.	Length
<b>730401</b>	PL-6	<b>6"</b>
<b>730402</b>	PL-8	<b>8"</b>
<b>730403</b>	PL-10	<b>10"</b>



730401 - 730403

## Groove Joint Pliers

PROD. NO.	MOD. NO.	Length	Capacity
<b>730441</b>	CLP-1	<b>7-1/2"</b>	1-1/4"
<b>730442</b>	CLP-2	<b>9-1/2"</b>	1-3/4"
<b>730443</b>	CLP-3	<b>12"</b>	2-1/4"



730442



730425



730483

## Long Nose Pliers

PROD. NO.	MOD. NO.	Length
<b>730423</b>	RP-150	<b>6-1/2"</b>
<b>730425</b>	RP-200	<b>8"</b>



## Bent Nose Pliers

PROD. NO.	MOD. NO.	Length
<b>730483</b>	BP-150	<b>6-1/2"</b>
<b>730485</b>	BP-200	<b>8"</b>



730428

730488



# LONG REACH SERIES - OPEN STOCK

## Long Nose Style

PROD. NO.	MOD. NO.	Length	Type
<b>730428</b>	LRP-1100	<b>11"</b>	Long Nose
<b>730488</b>	LRP-1145	<b>11"</b>	Bent Nose





# CHROME VANADIUM - OPEN STOCK

## Lineman's Pliers

PROD. NO.      MOD. NO.      Length

<b>730414</b>	CP-175	<b>7"</b>
<b>730415</b>	CP-200	<b>8"</b>
<b>730418</b>	CP-250HD	<b>9-3/4"</b>



730415

## Diagonal Cutting Pliers

- Unique shape and head configuration for best leverage and easiest cutting capabilities

PROD. NO.      MOD. NO.      Length      Type

<b>730433</b>	NP-150	<b>6-1/2"</b>	Diagonal Cutter
<b>730435</b>	NP-200	<b>7-1/2"</b>	Diagonal Cutter
<b>730221</b>	NPA-200HD	<b>8"</b>	Angle Head Cutter



Angle head  
730221 only



730433



730221

## Crimping Pliers

**730473** / WP-250HD

- 10" long
- A heavy duty cutter and crimping tool
- Not for use on live circuits



730473

## Box Joint Pliers

**730232** / BJP-250HD

- 10" long
- Chrome Vanadium steel
- Special jaw design for use on pipe
- Unique box joint adjusting system allows quick and easy one hand adjustments



730232

## 10" Fencing Pliers

**735102** / FT-10X

- Drop forged steel with blue cushion grip handles
- Ideal multi-purpose pliers for farmers and ranchers
- Hammer, staple remover and 2 wire cutters in 1 tool
- Length 10"



735102

**5 PC Chrome Nickel Pliers Set – Super Heavy Duty** **730305** / JPFD-5S

- Highest grade Chrome Nickel steel drop forged for ultimate strength
- Induction hardened teeth and exclusive laser hardened cutting edges for superior performance and long life
- Unique laser hardening process allows cutting of hardened materials including piano wire
- Patented high leverage design moves pivot point forward for increased cutting power and ease of use
- Handle springs on Lineman's, Diagonal Cutting, Bent Nose and Long Nose pliers open handles automatically, reducing fatigue and are easily removed if preferred
- Groove joint pliers feature undercut machined tongue and groove for greater strength at all jaw widths
- Right-angle teeth for superior grip
- Extra thick dual material handles provide unparalleled grip and user comfort
- Meets ANSI specifications



**FEATURES**

**High Leverage Design**

Patented High Leverage design moves pivot point forward for increased cutting power and ease of use

**Laser Hardened Cutting Edge**

Unique laser hardening process allows cutting of hardened materials including piano wire

**Spring Loaded Handles**

Handle springs on Linemans, Diagonal Cutting, and Long Nose pliers open handles automatically, reducing fatigue. Easily removed if preferred

**Induction Hardened Teeth**

Induction hardened right angle teeth for superior performance and long life

High Leverage Design  
Laser Hardened Cutting Edge  
Spring Loaded Handles





## Lineman's Pliers

- Unique laser hardening process allows cutting of hardened materials including piano wire
- Right angle teeth induction hardened to HRC55~60 for maximum grip
- Spring loaded handles reduce fatigue; spring can be easily removed and replaced if preferred

PROD. NO.	MOD. NO.	Length
<b>730236</b>	CP-200HD	<b>8"</b>

CrNi



## Diagonal Cutting Pliers

- Unique laser hardening process allows cutting of hardened materials including piano wire
- Spring loaded handles reduce fatigue; spring can be easily removed and replaced if preferred

PROD. NO.	MOD. NO.	Length
<b>730222</b>	NP-180HD	<b>7-1/4"</b>

CrNi



## Long Nose Pliers

- Unique laser hardening process allows cutting of hardened materials including piano wire
- Right angle teeth induction hardened to HRC55~60
- Spring loaded handles reduce fatigue; spring can be easily removed and replaced if preferred

PROD. NO.	MOD. NO.	Length
<b>730241</b>	RP-200HD	<b>8"</b>

CrNi



## Bent Nose Pliers

PROD. NO.	MOD. NO.	Length
<b>730246</b>	BP-200HD	<b>8"</b>

CrNi

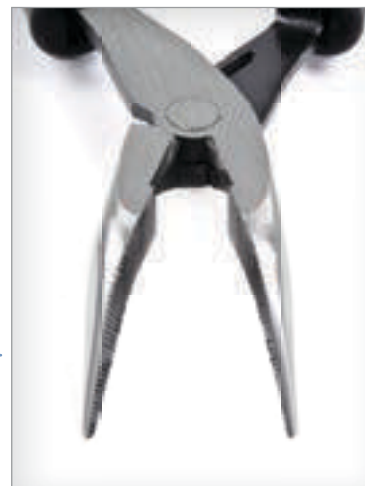

## Groove Joint Pliers

- Features undercut machined tongue and groove for maximum strength at all jaw widths
- Right angle teeth induction hardened to HRC55~60 for maximum grip

PROD. NO.	MOD. NO.	Length
<b>730216</b>	CLP-1HD	<b>8"</b>
<b>730217</b>	CLP-2HD	<b>10"</b>
<b>730218</b>	CLP-3HD	<b>12"</b>

CrNi



## Slip Joint Pliers

- Right angle teeth induction hardened to HRC55~60 for maximum grip

PROD. NO.	MOD. NO.	Length
<b>730206</b>	SJ-6HD	<b>6"</b>
<b>730207</b>	SJ-8HD	<b>8"</b>

CrNi



## End Nipper Pliers

- Ideal for flush cutting and concrete work

PROD. NO.	MOD. NO.	Length
<b>730227</b>	EN-200HD	<b>8"</b>

CrNi



## Cable Cutter

- For copper and aluminum cables only
- Maximum AWG 1 cable gauge

PROD. NO.	MOD. NO.	Length
<b>730251</b>	CC-200HD	<b>8"</b>

CrNi





**NEW**



735252



735256

**NEW**



735275

## SHEARS - SUPER HEAVY DUTY

▼ Hand Tools shown in this section feature:

- Top grade Japanese stainless steel for professional applications.
- Designed for left or right hand use.
- Vacuum heat treated for superior cutting edge and long life.

### Multi-Purpose Shears – Super Heavy Duty

- Serrated blades prevent material from being pushed forward, making cutting easier and more accurate
- Hardened stainless steel nut and bolt for adjustable tension
- Dual material Polypropylene and Thermoplastic Rubber handles for strength and secure grip
- Suitable for cutting branches, dowels, cardboard, rope, cord, wire, and many other materials

PROD. NO.	MOD. NO.	Overall Length	Cutting Length	Type
<b>735252</b>	JMPS-145	5-3/4"	1-1/4"	Straight
<b>735253</b>	JMPS-190	7-1/2"	1-5/8"	Straight
<b>735254</b>	JMPS-190A	7-1/4"	1-5/8"	Angled
<b>735255</b>	JMPS-200	8"	2"	Straight
<b>735256</b>	JMPS-200A	8"	2"	Angled



### 8" Utility Shears – Super Heavy Duty

- High leverage design transmits power more efficiently for easier cutting
- Suitable for cutting thick cloth, upholstery, leather, rubber, vinyl, fabric, rope, cardboard, paper, poultry and many other materials
- Thermoplastic elastomer handles are tough, pliable, and comfortable to use

PROD. NO.	MOD. NO.	Overall Length	Cutting Length	Type
<b>735275</b>	JUS-200	8"	2-1/2"	Straight

# SHEARS

▼ *Hand Tools shown in this section feature:*

- Top grade Japanese stainless steel for professional applications.
- Designed for left or right hand use.
- Vacuum heat treated for superior cutting edge and long life.



**NEW**



## Electrician's - Super Heavy Duty

- Hollow ground blades requires less cutting effort
- Serrated blade prevents material from being pushed forward, making cutting easier and more accurate
- Dedicated wire stripping notch
- Fibreglass reinforced nylon handles with thermoplastic rubber overmould for superior strength and grip
- Suitable for cutting soft cable, insulation, electrical tape, cable ties and many other materials

PROD. NO	MOD. NO.	Overall Length	Cutting Length	Wire Cutter Notch
<b>735262</b>	JECS-140	5-1/2"	1-5/8"	✓

**NEW**



## Kevlar® Shears - Super Heavy Duty

- Specially selected high carbon alloy steel for use on Kevlar® materials
- Cutting edges induction hardened to HV1200
- Hollow ground blades requires less cutting effort
- Serrated blade prevents material from being pushed forward, making cutting easier and more accurate
- Fibreglass reinforced nylon handles with thermoplastic rubber overmould for superior strength and grip
- Suitable for cutting Kevlar®, insulation materials, electrical tape, cable ties, and many other materials
- Kevlar® is a registered trademark of E. I. du Pont de Nemours and Company

PROD. NO	MOD. NO.	Overall Length	Cutting Length
<b>735264</b>	JECS-140K	5-1/2"	1-5/8"



# WIRE STRIPPERS AND CUTTERS

## Automatic Wire Stripper 730731 / JAWS-822

- One quick light squeeze strips wire up to a full 1" without nicking, cutting or fraying
- Automatic wire gripper holds wire centered in stripping hole
- Lever action offers stripping and insulation removal in one step
- Adjustable wire stop to ensure uniform, precise strip length
- Overall Length 7"
- Stripping Capacity: **8, 10, 12, 14, 16, 18, 20, 22** AWG solid and stranded



## V-Groove Wire Stripper 730738 / JVWS-51024

- Hardened carbon steel with black oxide finish for corrosion resistance
- Quickly adjusts from **AWG 10 - 24**
- Spring loaded for easy one hand use
- Overall length **5-1/4"**
- Capacity: **10, 12, 14, 16, 18, 20, 22, 24** AWG solid and stranded

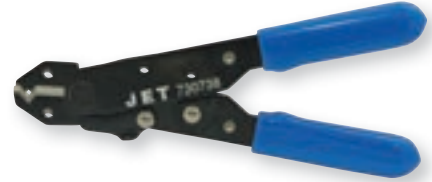

## Self Adjusting Wire Stripper 730736 / JAWS-100

- Self adjusting stripper automatically applies correct pressure to strip insulation without nicking wire
- Fine adjustment screw allows customized pressure on various plastic insulation
- Can be used to strip several wires simultaneously
- Includes wire cutter
- Overall length **6-1/2"**



## Spring Loaded Strippers / Cutters

- All cutting and stripping surfaces are precision machined to produce clean, exacting results
- High carbon heat treated steel for long life
- Black oxide finish resists rust and corrosion
- All models feature holes for looping and serrated tips for pulling wire
- Strippers / cutters are spring loaded for easy one hand operation and have safety lock (except 730724)
- Multifunction tools cut, strip and crimp insulated and non-insulated terminals
- For use on copper and aluminum wire only



730725      730724      730711

PROD. NO.	MOD. NO.	Overall Length	Stripping Capacity	Crimping Capacity	Bolt Size & Thread
730711	JWCS-61020	6-1/4"	10, 12, 14, 16, 18, 20 AWG solid and stranded	N/A	N/A
730724	JMWS-81024	8-1/4"	8, 10, 12, 14, 16, 18, 20, 22 AWG solid; 12, 14, 16, 18, 20, 22, 24, 26 AWG stranded	10-22 AWG	4-40, 5-40, 6-32, 8-32, 10-32, 10-24
730725	JMWS-9618	9"	6, 8, 10, 12, 14, 16 AWG solid; 8, 10, 12, 14, 16, 18 AWG stranded	10-22 AWG	4-40, 5-40, 6-32, 8-32, 10-32, 10-24



# RIVET TOOLS

- Designed for industrial use
- All steel construction
- All models designed for use with aluminum rivets
- 859044 (JRT-707) for use with aluminum and steel rivets
- 859043 (JRT-736) features 360° swivel head



## Hand Riveters – Heavy Duty

PROD. NO.	MOD. NO.	Description	Nozzles	Length (Overall)
<b>859042</b>	JRT-200	Long Nose	3/32, 1/8, 5/32, 3/16"	—
<b>859043</b>	JRT-736	Swivel Head 360°	3/32, 1/8, 5/32, 3/16"	—
<b>859044</b>	JRT-707	Long Reach, <i>use with aluminum and steel rivets</i>	1/8, 5/32, 3/16, 7/32, 1/4"	21"
—	PUT-JRT707	Repair Kit	—	—



859042

360° Swivel Head



859043



859044



**DID YOU KNOW?**  
JET Carries a complete line of professional pneumatic rivet guns. See our AIR TOOLS catalogue for details

Made of the highest quality drop forged Chrome Molybdenum steel for professional use



Precision serrated cutting blades

Canada's premier sheet metal snip – lasts up to 2-1/2 times the life of leading brands!

# SHEET METAL TOOLS



735305

## AVIATION SNIPS - SUPER HEAVY DUTY

- Made of the highest quality drop forged Chrome Molybdenum steel for professional use
- Induction hardened to HRC 60 – 62
- Serrated cutting edges prevent material from slipping out of blade
- Compound action reduces cutting effort
- Colour coded TPR handles provide maximum comfort
- Unique automatic release latch for easy one hand operation
- Regular, offset, notching and extra long models cover every application

### 3 PC Traditional Style Set

PROD. NO.	MOD. NO.	Description	Overall Length
735305	JAS-3S	Straight cut, Left cut and Right cut	10"



## Traditional Style - Open Stock

PROD. NO.	MOD. NO.	Description	Overall Length	Length to Cut	MAXIMUM MATERIAL THICKNESS (GAUGE)			
					Copper (soft)	Cold Rolled Steel (med.)	Hard Steel (HRC35)	304 Stainless Steel
735301	JAS-1S	<b>Straight</b>	10"	1-1/2"	16	18	21	22
735302	JAS-1R	<b>Right Cut</b>	10"	1-3/8"	16	18	21	22
735303	JAS-1L	<b>Left Cut</b>	10"	1-3/8"	16	18	21	22
735311	JAS-1SL	<b>Long Cut</b>	11-3/8"	3"	19	20	22	25
735391	JBS-1	<b>Bull Dog</b>	9"	1"	14	16	18	18

**CrMo**



## Offset Style - Open Stock

PROD. NO.	MOD. NO.	Description	Overall Length	Length to Cut	MAXIMUM MATERIAL THICKNESS (GAUGE)			
					Copper (soft)	Cold Rolled Steel (med.)	Hard Steel (HRC35)	304 Stainless Steel
735322	JOS-1R	<b>Right Cut</b>	9-1/4"	1-3/16"	16	18	21	22
735323	JOS-1L	<b>Left Cut</b>	9-1/4"	1-3/16"	16	18	21	22

**CrMo**

## 10" Tin Snip

735210 / JTS-10

- Made of drop forged high carbon steel
- One piece solid steel construction
- Smooth finished blades for cleaner cutting

Overall Length	Length to Cut	MAXIMUM MATERIAL THICKNESS (GAUGE)			
		Copper (soft)	Cold Rolled Steel (med.)	Hard Steel (HRC35)	304 Stainless Steel
10"	2"	20	22	24	26







# VDE Tools

NUT DRIVERS  
PLIERS  
SCREWDRIVERS  
TOOL KITS



- Electrically shielded tools for use on live circuits
- Individually tested and VDE certified to 1,000 V for maximum user protection
- Co-moulded polypropylene and thermoplastic vulcanizates ensure maximum strength balanced with superior non-slip grip
- Resistant to most chemicals, solvents, and oil
- Use on service panels, switch boxes, electric and hybrid automobiles, or anytime work must be performed while circuit is potentially live
- All items meet IEC60900:2004 standards

# VDE TOOLS

## VDE TOOL KITS

**NEW**



### 10 PC Tool Kit

760002 / JITK-10S

- Contains most commonly used VDE screwdrivers and pliers
- Includes case

PROD. NO.	MOD. NO.	Includes
760213	JISS-5	7/32" x 5" Slot
760214	JISS-6	1/4" x 6" Slot
760236	JISR-2	#2 Square
760224	JISP-1	#1 Phillips
760226	JISP-2	#2 Phillips
760341	JIWS-6	6" Wire Stripper
760312	JILP-8	8" Lineman's Pliers
760322	JILN-8	8" Long Nose Pliers
760332	JINP-8	8" Diagonal Cutter
760352	JIWP-10	10" Water Pump Pliers



## 9 PC Screwdriver Set

760202 / JISD-9S

- Includes pouch

PROD. NO.	MOD. NO	Includes
760211	JISS-4	5/32" x 4" Slot
760213	JISS-5	7/32" x 5" Slot
760214	JISS-6	1/4" x 6" Slot
760221	JISP-0	#0 Phillips
760224	JISP-1	#1 Phillips
760226	JISP-2	#2 Phillips
760228	JISP-3	#3 Phillips
760234	JISR-1	#1 Square
760236	JISR-2	#2 Square



**NEW**



**NEW**

## 5 PC Nut Driver Set

760252 / JIND-5S

- Includes pouch

PROD. NO.	MOD. NO	Includes
760262	JIND-14	1/4" Nut Driver
760263	JIND-516	5/16" Nut Driver
760265	JIND-38	3/8" Nut Driver
760266	JIND-716	7/16" Nut Driver
760267	JIND-12	1/2" Nut Driver

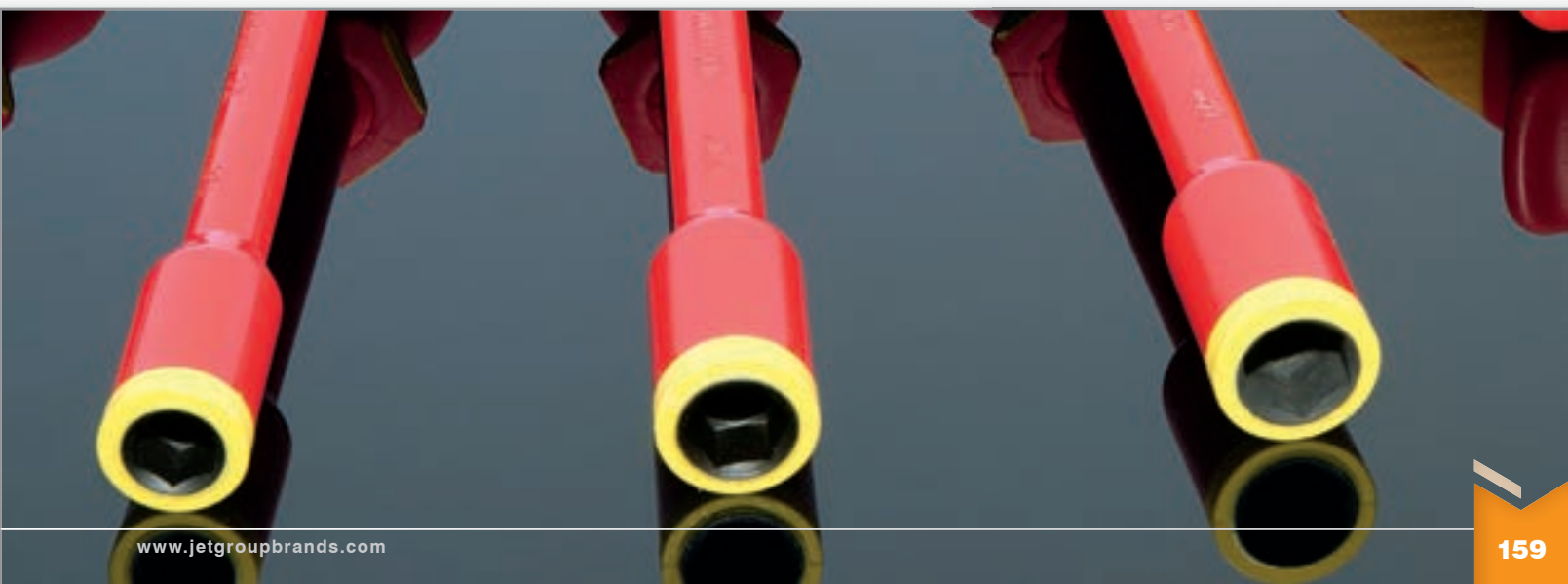



**NEW**

## VDE SCREWDRIVERS - OPEN STOCK

- Two layers of insulation provide ultimate protection. **Warning:** if yellow layer is exposed through the red layer, tool has been damaged and should be retired
- Unique handle design conforms to the hand for exceptional comfort and grip
- Pentagon shaped neck bolster minimizes roll away
- Tip size and style on handle ends for easy identification in tool pouch
- Patented SVCM tool steel is up to 30% stronger than CrV screwdrivers
- Phosphate plated tips will not chip or peel



760224

760213

### Slot Screwdrivers ⊖

PROD. NO.	MOD. NO.	Size
760211	JISS-4	5/32" x 4"
760213	JISS-5	7/32" x 5"
760214	JISS-6	1/4" x 6"

### Phillips Screwdrivers ⊕

PROD. NO.	MOD. NO.	Size
760221	JISP-0	#0
760224	JISP-1	#1
760226	JISP-2	#2
760228	JISP-3	#3

### Square Screwdrivers ⊞

PROD. NO.	MOD. NO.	Size
760234	JISR-1	#1
760236	JISR-2	#2

SVCM





## VDE NUT DRIVERS - OPEN STOCK

- Two layers of insulation provide ultimate protection. **Warning:** if yellow layer is exposed through the red layer, tool has been damaged and should be retired
- Unique handle design conforms to the hand for exceptional comfort and grip
- Pentagon shaped neck bolster minimizes roll away
- Size printed on handle ends for easy identification in tool pouch
- Chrome Vanadium steel for professional use

### Nut Drivers

PROD. NO.	MOD. NO.	Size
<b>760262</b>	JIND-14	1/4"
<b>760263</b>	JIND-516	5/16"
<b>760265</b>	JIND-38	3/8"
<b>760266</b>	JIND-716	7/16"
<b>760267</b>	JIND-12	1/2"



**NEW**



760267

## VDE PLIERS AND CUTTERS - OPEN STOCK

- Drop forged Chrome Vanadium steel with induction hardened cutting edges
- Handle bolster for positive stop between insulated handle and non-insulated steel components

### Pliers and Cutters

PROD. NO.	MOD. NO.	Description
<b>760341</b>	JIWS-6	6" Wire Stripper
<b>760312</b>	JILP-8	8" Lineman's Pliers
<b>760322</b>	JILN-8	8" Long Nose Pliers
<b>760332</b>	JINP-8	8" Diagonal Cutter
<b>760352</b>	JIWP-10	10" Water Pump Pliers







# Pipe Tools



- PIPE WRENCHES
- TUBE CUTTERS
- PIPE CUTTERS
- DEBURRING TOOLS
- RATCHETING CUTTERS
- TUBING BENDERS
- FLARING TOOLS



710145

**NEW**

710245

**NEW**

## PIPE WRENCHES

### Steel - Heavy Duty

- Hardened Chrome Vanadium steel hook and heel jaws for professional applications
- Induction hardened teeth provide exceptional grip
- Powder coat paint for protection against corrosion
- Heel jaw attached with roll pin for easy replacement
- Meets US Federal Government Specification GGG-651 type II Class A

PROD. NO.	MOD. NO.	Length	Jaw Capacity
<b>710142</b>	JPW-8	<b>8"</b>	1"
<b>710143</b>	JPW-10	<b>10"</b>	1-1/2"
<b>710144</b>	JPW-12	<b>12"</b>	2"
<b>710145</b>	JPW-14	<b>14"</b>	2"
<b>710147</b>	JPW-18	<b>18"</b>	2-1/2"
<b>710150</b>	JPW-24	<b>24"</b>	3"
<b>710156</b>	JPW-36	<b>36"</b>	5"
<b>710159</b>	JPW-48	<b>48"</b>	6"

**CrV**

### Aluminum - Heavy Duty

- Hardened Chrome Vanadium steel hook and heel jaws for professional applications
- Induction hardened teeth provide exceptional grip
- Aluminum handle is up to 40% lighter than steel handles
- Heel jaw attached with roll pin for easy replacement
- Meets US Federal Government Specification GGG-651 type I Class B.10

PROD. NO.	MOD. NO.	Length	Jaw Capacity
<b>710245</b>	JPWA-14	<b>14"</b>	2"
<b>710247</b>	JPWA-18	<b>18"</b>	2-1/2"
<b>710250</b>	JPWA-24	<b>24"</b>	3"
<b>710256</b>	JPWA-36	<b>36"</b>	5"
<b>710259</b>	JPWA-48	<b>48"</b>	6"

**CrV**



710124

## PIPE WRENCHES

### Steel - Super Heavy Duty

- Super Heavy duty cast steel handles for professional use
- Extra heavy duty cast head design is 20% stronger than competitive brands
- **Chrome Molybdenum** hook and heel jaws for longest life and maximum grip
- Jaws hardened to HRC 52 – 58
- Powder-coated for maximum resistance to corrosion
- Induction hardened teeth provide exceptional grip
- Heel jaws attached using roll pins for easy replacement
- Meets US Federal Government Specification GGG-651 type II Class A

PROD. NO.	MOD. NO.	Length	Jaw Capacity
710122	PW-8	8"	1-3/16"
710123	PW-10	10"	1-13/16"
710124	PW-12	12"	2-7/16"
710125	PW-14	14"	2-7/16"
710127	PW-18	18"	2-7/8"
710130	PW-24	24"	3-3/16"
710136	PW-36	36"	5-1/4"

### Aluminum - Super Heavy Duty

- Heavy duty lightweight aluminum handles for professional use
- Extra heavy duty cast head design is 20% stronger than competitive brands
- **Chrome Molybdenum** hook and heel jaws for longest life and maximum grip
- Jaws hardened to HRC 52 - 58
- Powder-coated for maximum resistance to corrosion
- Induction hardened teeth provide exceptional grip
- Heel jaws attached using roll pins for easy replacement
- Meets US Federal Government Specification GGG-651 type II Class A

PROD. NO.	MOD. NO.	Length	Jaw Capacity
710225	PWA-14	14"	2-7/16"
710227	PWA-18	18"	2-7/8"
710230	PWA-24	24"	3-3/16"
710236	PWA-36	36"	5-1/4"
710239	PWA-48	48"	6"



710227



H1179



739109



Spare cutting wheel included

739102

Fold away deburring tool



Spare cutting wheel included

739104

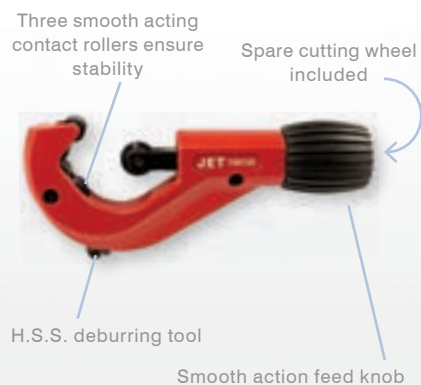

Three smooth acting contact rollers ensure stability

Spare cutting wheel included

H.S.S. deburring tool

Smooth action feed knob

## TUBE CUTTERS

### Mini Tube Cutters

- Compact overall size for use where space is restricted
- Cuts copper, brass, aluminum and thin wall steel conduit
- Hardened steel cutting wheel for copper cutting
- Replacement cutters: **739191** copper, **739193** stainless steel

PROD. NO.	MOD. NO.	Capacity	Replacement Cutters
<b>H1179</b>	—	1/8" – 5/8" O.D.	<b>739191</b> copper, <b>739193</b> stainless steel
<b>739109</b>	JMTC-30	1/8" – 1-1/8" tubing (3 – 30 mm)	<b>739192</b> copper, <b>739194</b> stainless steel

### 1-1/8" Screw Feed Tube Cutter

**739102 / JTC-30**

- Cuts copper, brass, aluminum and thin wall steel conduit
- Cuts **1/8" – 1-1/8"** (3 – 30 mm) tubing
- Grooved rollers allow cutting close to flare
- One piece sliding block for longest life and accurate cuts
- Includes fold away deburring tool
- Contoured adjustment knob houses spare cutting wheel
- Hardened steel cutting wheel for copper cutting
- Replacement cutters: **739191** copper, **739193** stainless steel

### Telescopic Tube Cutters

- Telescopic cutter requires no additional room to open to full capacity
- Cuts copper, brass, aluminum and thin wall steel conduit
- Grooved rollers allow cutting close to flare
- Hardened steel cutting wheel for copper cutting
- Includes spare cutting wheel for copper cutting

PROD. NO.	MOD. NO.	Capacity	Replacement Cutters
<b>739104</b>	JTTC-32	1/8" – 1-1/4"	<b>739191</b> copper, <b>739193</b> stainless steel
<b>739105</b>	JTTC-42	1/8" – 1-5/8"	<b>739192</b> copper, <b>739194</b> stainless steel

See page 168 for replacement cutters

# TUBE CUTTERS



## 2" Quick Adjustable Tube Cutter 739107 / JOAC-50

- Spring loaded cutter wheel feed system allows slide action adjustment and quick release
- Cuts copper, brass, aluminum and thin wall steel conduit
- Cuts **1/4 – 2"** (6 – 50 mm) tubing
- Grooved rollers allow cutting close to flare
- Hardened steel cutting wheel for copper cutting
- Includes fold away deburring tool
- Contoured adjustment knob houses spare cutting wheel
- Replacement cutters: **739192** copper, **739194** stainless steel

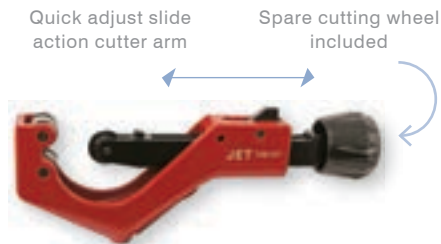

## 1-1/8" Ratchet Tube Cutter 739108 / JRTC-28

- Ratchet action cutter allows cutting of tubes without having to rotate 360°
- Open end design is ideal for cutting sections of pipe in walls and other limited access areas
- Simply close cutter on tube and move back and forth until cut is made
- Cuts **5/16 – 1-1/8"** (8 – 29 mm) tubing
- Replacement cutters: **739192** copper, **739194** stainless steel



Ratchet mechanism rotates head 360° inside handle, allowing pipe cutting in confined spaces

# PIPE CUTTER

## 2" Iron Pipe Cutter 739111 / JPC-50

- Heavy duty drop forged steel body for demanding applications
- Ideally suited for cutting steel and iron pipes
- Can also be used on copper, brass, and aluminum tubing and thin wall conduit
- Cuts **1/8 – 2"** (3 – 50 mm) tubing
- Hardened steel cutting wheel
- Large ergonomic feed handle
- Replacement cutter: **739195**



# TUBE BENDER

## 3-in-1 Tube Bender 739142 / JTB-90

- Bends **1/4, 5/16, and 3/8"** soft tubing
- Compact design for use in confined areas
- Aluminum construction is rust proof
- Bends tubing smoothly without kinking or crushing
- Calibrated for quick reference



See page 168 for replacement cutters



H.S.S. Blades



H.S.S. Blades

Unique blade profile prevents crushing of pipe

Stainless steel blade for professional use



Ratcheting mechanism for fast / progressive cutting

## DEBURRING TOOLS

### 6" Deburring Tool

739122 / JDT-100

- Large diameter contoured plastic handle
- High speed steel blades for cutting copper, brass, aluminum and stainless steel
- Spare blade is included and housed inside handle
- Push button blade release for fast blade changes
- Suitable for left and right hand cutting
- Overall length: 6"
- Replacement cutter: **739197**

### 6" Pocket Clip Deburring Tool

739125 / JDT-500

- Sleek aluminum body with pocket clip
- High speed steel blade for cutting copper, brass, aluminum and stainless steel
- Blade is easily replaceable
- Suitable for left and right hand cutting
- Overall length: 6"
- Replacement cutter: **739197**

## RATCHETING PVC PIPE CUTTER

### 1-5/8" PVC Pipe Cutter

739116 / JPPC-42

- Ratcheting action for easy progressive cutting
- Stainless steel blade
- Unique blade profile pierces pipe and prevents crushing
- Maximum capacity: **1-5/8"** (42 mm)
- Replacement blade: **739198**

### For All Cutters

### Replacement Blades and Cutters

PROD. NO.	Application	Fits
<b>739191</b>	copper, brass, aluminum, steel	739109 (JMTC-30)
		739102 (JTC-30)
		739104 (JTTC-32)
<b>739192</b>	copper, brass, aluminum, steel	739105 (JTTC-42)
		739107 (JQAC-50)
		739108 (JRTC-28)
<b>739193</b>	stainless steel	739109 (JMTC-30)
		739102 (JTC-30)
		739104 (JTTC-32)
<b>739194</b>	stainless steel	739105 (JTTC-42)
		739107 (JQAC-50)
		739108 (JRTC-28)
<b>739195</b>	copper, brass, aluminum, steel, iron	739111 (JPC-50)
<b>739197</b>	copper, brass, aluminum, steel, iron, stainless steel	739122 (JDT-100)
		739125 (JDT-500)
<b>739198</b>	copper, brass, aluminum, steel, iron, stainless steel	739116 (JPPC-42)



**Flaring Tool** **739132 / JFT-100**

- Provides 45° flare or can be used with double flaring inserts
- Designed for use on **3/16, 1/4, 5/16, 3/8, 7/16, 1/2 and 5/8" tubing**
- Cast iron yoke
- Fully polished tubing clamp
- For soft copper, brass and aluminum tubing



**Flaring Tool - Heavy Duty** **739133 / JFT-200**

- Provides 45° flare or can be used with double flaring inserts
- Designed for use on **3/16, 1/4, 5/16, 3/8, 7/16, 1/2 and 5/8" tubing**
- Drop forged yoke and hardened steel tubing clamp for professional applications
- Ideal for automotive, HVAC, hydraulic and other heavy duty applications
- Can be used on copper, brass, aluminum and stainless steel tubing

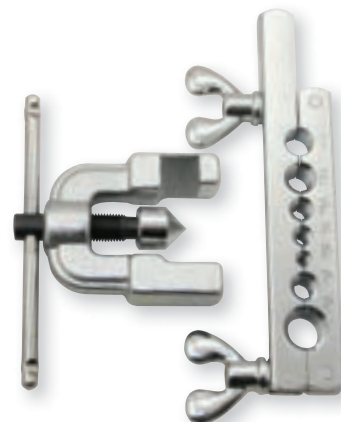

**I.S.O. Bubble Flaring Tool Kit** **H1502**

- Front wheel drive cars and light trucks, both foreign and domestic, are installing the I.S.O. sized steel brake lines with the I.S.O. flare. This is different from the standard double flare
- Accomplishes the I.S.O. flare without removing the brake line from the vehicle, and has the strength to withstand the pressure necessary to flare mild steel tube (1.0mm wall thickness) used on the front wheel drive brake line
- Yoke is made of a heat treated, alloy steel drop forging, with a special patented centre screw
- Bar assembly is hardened and will hold up under repeated use and produces a smooth, consistent flare
- Kit is complete with flaring tool, four special adaptors, a chamfering tool and a combination wrench and height gauge

**Kit Includes:**

- **H1502A** Adaptor **4.75 mm**
- **H1502B** Adaptor **6 mm**
- **H1502C** Adaptor **8 mm**
- **H1502D** Adaptor **10 mm**
- **H1502E** Bar Assembly
- **H1502F** Yoke Assembly
- **H1502G** Reamer
- **H1502H** Wrench

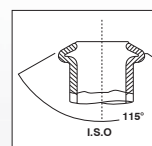

PIPE AND TUBING TOOLS  
SEE PAGE 254 IN THE SPECIALTY  
AUTO SECTION FOR SIMILAR  
PRODUCTS

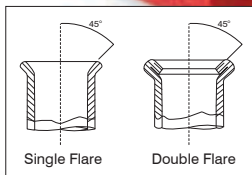

Kit includes tube cutter



## FLARING TOOLS

### Double Flaring Tool Kit – S.A.E.

**H1120**

- Built to provide the necessary pressure to double flare steel brake tube
- Will double and single flare both copper and steel tube
- Double flare adaptors provided for **3/16, 1/4, 5/16, 3/8 and 1/2"** tube
- Alloy steel swivel is heat-treated, ground, and chromed to reduce compression friction
- Yoke and bar is forged and tempered for added strength

**Kit Includes:**
**H1120A** Double Flare adaptor **3/16"**
**H1120E** Double Flare adaptor **1/2"**
**H1120B** Double Flare adaptor **1/4"**
**H1120F** Bar Assembly

**H1120C** Double Flare adaptor **5/16"**
**H1120G** Yoke and Bolt Assembly

**H1120D** Double Flare adaptor **3/8"**
**H1120H** Wingnut

### Double Flaring Tool Kit - Metric

**H1121**

- Built to provide the necessary pressure to double flare steel brake tube
- Will double and single flare both copper and steel tube
- Double flare adaptors provided for **3/16, 1/4, 5/16, 3/8 and 1/2"** tube
- Alloy steel swivel is heat-treated, ground, and chromed to reduce compression friction
- Yoke and bar is forged and tempered for added strength

**Kit Includes:**
**H1121A** Double Flare adaptor **4.75 mm**
**H1121E** Double Flare adaptor **10 mm**
**H1121B** Double Flare adaptor **5 mm**
**H1121F** Bar Assembly

**H1121C** Double Flare adaptor **6 mm**
**H1121G** Yoke and Bolt Assembly

**H1121D** Double Flare adaptor **8 mm**
**H1120H** Wingnut

### Double Flaring and Cutting Tool Kit - S.A.E. 739181 / JTFK-100

- Includes 739102 (JTC-30) Tubing Cutter, 739132 (JFT-100) Flaring Tool and Double Flaring Inserts for **3/16, 1/4, 5/16, 3/8, 7/16, 1/2 and 5/8"** tube
- Provides automotive type double flare or use without inserts for 45° flare
- Cuts up to 1-1/8" (30 mm) tube
- For soft copper, brass and aluminum tube
- Complete with blow mould storage case
- Replacement Double Flaring Dies:

**3/16" – H1120A**
**7/16" – H1120J**
**1/4" – H1120B**
**1/2" – H1120E**
**5/16" – H1120C**
**5/8" – H1120K**
**3/8" – H1120D**



# Striking Tools

HAMMERS  
PUNCHES AND CHISELS  
AXES AND MAULS  
STAMPS



740307



740347



740348



## NAILING HAMMERS

### Hickory Handle - Heavy Duty

- American hickory handles
- Forged steel heads are hardened and tempered for professional use
- Meets ANSI specifications

PROD. NO.	MOD. NO.	Head Weight	Length (Overall)	Style
<b>740307</b>	CW16F	<b>16 oz</b>	13"	Claw

### Fibreglass Handle - Heavy Duty

- Highest fibreglass content for maximum strength
- Polymer jacketed to prevent splintering
- PVC grips for user comfort and safety
- Forged steel heads are hardened and tempered for professional use
- New improved bonding technology rated for use to -25°C
- Meets ANSI specifications

PROD. NO.	MOD. NO.	Head Weight	Length (Overall)	Style
<b>740347</b>	CF16F	<b>16 oz</b>	13"	Claw

### Fibreglass Handle - Super Heavy Duty

- Popular "California" style framing hammer
- 1045 medium carbon steel head hardened and tempered to prevent chipping or mushrooming
- Increased head weight designed to drive larger framing nails quickly
- Extra wide milled striking face reduces missed strikes
- Straight claws make removing nails easier
- Extra thick handle at head end for added strength and resistance to overstrikes
- Grips made of high quality thermoplastic elastomers for excellent comfort and non-slip use
- Meets ANSI specifications

PROD. NO.	MOD. NO.	Head Weight	Length (Overall)	Style
<b>740348</b>	CFH-21	<b>21 oz</b>	16-1/2"	Framing

## All Steel - Super Heavy Duty

- One piece steel handle is virtually immune to overstrikes
- 1055 medium carbon steel heads are hardened and tempered to prevent chipping or mushrooming
- Magnetic nail holder allows single hand use and accommodates different size nails (ripping hammer only)
- Milled face of ripping hammer minimizes slipping off the nail
- Claw hammer has smooth face for finishing work
- Grips made of high quality polypropylene and thermoplastic elastomers for excellent comfort and non-slip use
- Handle grip riveted to prevent separation
- Meets ANSI specifications

PROD. NO.	MOD. NO.	Head Weight	Length (Overall)	Style	Face
<b>740321</b>	CAS-16	<b>16 oz</b>	13"	Claw	Smooth
<b>740331</b>	RAS-22	<b>22 oz</b>	15-3/4"	Ripping	Milled



## Anti-Shock All Steel - Super Heavy Duty

- One piece steel handle with "tuning fork" design absorbs and dissipates vibrations through the handle rather than transmitting them to the user's forearm and elbow
- Greatly reduces fatigue and stress
- 1055 medium carbon steel heads are hardened and tempered to prevent chipping or mushrooming
- Magnetic nail holder allows single hand use and accommodates different size nails
- D-face design allows nails to be driven when close to walls or other surfaces
- Milled face of ripping hammer minimizes slipping off the nail
- Claw hammer has smooth face for finishing work
- Grips made of high quality polypropylene and thermoplastic elastomers for excellent comfort and non-slip use
- Handle grips riveted to prevent separation
- Meets ANSI specifications

PROD. NO.	MOD. NO.	Head Weight	Length (Overall)	Style	Face
<b>740381</b>	CAV-16	<b>16 oz</b>	13"	Claw	Smooth
<b>740386</b>	RAV-20	<b>20 oz</b>	13-3/4"	Ripping	Milled





740158



740166



740103



## BALL PEIN HAMMERS

### Hickory Handle - Heavy Duty

- American hickory handles
- Forged steel heads are hardened and tempered for professional use
- Meets ANSI specifications

PROD. NO.	MOD. NO.	Head Weight	Length (Overall)
<b>740151</b>	BP-8H	<b>8 oz</b>	11-1/2"
<b>740153</b>	BP-16H	<b>16 oz</b>	14"
<b>740155</b>	BP-24H	<b>24 oz</b>	15"
<b>740157</b>	BP-32H	<b>32 oz</b>	15"
<b>740158</b>	BP-40H	<b>40 oz</b>	15-3/4"

### Fibreglass Handle - Heavy Duty

- Highest fibreglass content for maximum strength
- Polymer jacketed to prevent splintering
- PVC grips for user comfort and safety
- Forged steel heads are hardened and tempered for professional use
- New improved bonding technology rated for use to -25°C
- Meets ANSI specifications

PROD. NO.	MOD. NO.	Head Weight	Length (Overall)
<b>740161</b>	BP-08F	<b>8 oz</b>	11"
<b>740163</b>	BP-16F	<b>16 oz</b>	13"
<b>740164</b>	BP-24F	<b>24 oz</b>	14-1/2"
<b>740165</b>	BP-32F	<b>32 oz</b>	15"
<b>740166</b>	BP-40F	<b>40 oz</b>	15-1/2"

### Steel Handle - Super Heavy Duty

- All steel handle is virtually immune to overstrikes
- 1055 medium carbon steel heads are hardened and tempered to prevent chipping or mushrooming
- Sand blast finish with fully polished striking faces
- TPR (Thermoplastic Rubber) handle grips absorb shock and provide excellent grip
- Handle grip riveted to prevent separation
- Meets ANSI specifications

PROD. NO.	MOD. NO.	Head Weight	Length (Overall)
<b>740103</b>	JSPB-16	<b>16 oz</b>	13"
<b>740105</b>	JSBP-24	<b>24 oz</b>	13-1/2"
<b>740107</b>	JSBP-32	<b>32 oz</b>	14-1/2"

# BALL PEIN HAMMERS

## Indestructible Handle - Super Heavy Duty

- Spring steel rods encased in vulcanized rubber provide the ultimate striking tool handle
- Handle absorbs impact and vibration, reducing user fatigue
- Will not break, bend, or split even after repeated overstrikes
- Patented locking plate makes head separation impossible
- Provides unparalleled grip in all conditions and is resistant to most industrial chemicals
- Drop forged heads heat-treated to HRC 52-56
- Developed for the mining industry, these hammers are ideal for use in applications where a failure is more than just an inconvenience
- Lifetime Warranty
- Meets ANSI specifications

PROD. NO.	MOD. NO.	Head Weight	Product Weight	Length (Overall)
<b>740174</b>	UBP-2414	<b>24 oz</b>	<b>2.2 lb</b>	14"
<b>740175</b>	UBP-3214	<b>32 oz</b>	<b>2.7 lb</b>	14"
<b>740176</b>	UBP-4814	<b>48 oz</b>	<b>3.7 lb</b>	14"

## Deadblow - Super Heavy Duty

- One piece oven cured Polyurethane shell is much tougher than PVC, plastic, or rubber – up to 5 times the life
- Steel shot filled head directs full force of blow to the work, preventing rebound
- Precision tempered alloy steel striking face and ball pein hardened to HRC 48-54
- Beveled crown for accurate strikes
- Solid steel skeleton provides added strength and resists breaking on overstrike

PROD. NO.	MOD. NO.	Head Weight	Product Weight	Head Length	Face Diameter	Length (Overall)
<b>740983</b>	DBBP-16	<b>1 lb</b>	<b>16 oz</b>	4-1/4"	1-1/4"	12-3/4"
<b>740984</b>	DBBP-24	<b>1-1/2 lb</b>	<b>24 oz</b>	4-1/2"	1-1/2"	13"
<b>740985</b>	DPPB-32	<b>2 lb</b>	<b>32 oz</b>	4-7/8"	4-7/8"	16-1/4"

# CLUB HAMMER

- All steel handle is virtually immune to overstrikes
- 1055 medium carbon steel head hardened and tempered to prevent chipping or mushrooming
- Sand blast finish with fully polished striking faces
- TPR handle grip absorb shock and provide excellent grip
- Handle grip riveted to prevent separation
- Meets ANSI specifications

## All Steel Club Hammer - Super Heavy Duty

PROD. NO.	MOD. NO.	Head Weight	Length (Overall)
<b>740191</b>	JSCH-25	<b>2-1/2 lb</b>	10-3/4"



STRIKING TOOLS  
INDESTRUCTIBLE HANDLE



740175



740983



740191

JET



# STRIKING TOOLS

## INDESTRUCTIBLE HANDLE



### STEEL LOCKING PLATE

Makes head separation impossible

### HIGH VISIBILITY HEAD

Adds instant identification on any job site

### VULCANIZED RUBBER GRIP

Absorbs impact and vibration, reducing user fatigue; made from special grade ozone resistant rubber for use in tough environments

### DROP FORGED HEAD

With striking ends induction heat treated to HRC 52-56

### SPRING STEEL BARS

9/32" (7.1mm) diameter spring steel bars resist overstrike without breaking

### TEXTURED NON-SLIP GRIP

### STEEL REINFORCED LANYARD HOLE

Lifetime  
Warranty





# INDESTRUCTIBLE HANDLE HAMMERS

- Spring steel rods encased in vulcanized rubber provide the ultimate striking tool handle
- Handle absorbs impact and vibration, reducing user fatigue
- Will not break, bend, or split even after repeated overstrikes
- Patented locking plate makes head separation impossible
- Provides unparalleled grip in all conditions and is resistant to most industrial chemicals
- Drop forged heads heat-treated to HRC 52-56
- Lifetime Warranty
- Meets ANSI specifications

## Steel Head

- Developed for the mining industry, these hammers are ideal for use in applications where a failure is more than just an inconvenience

PROD. NO.	MOD. NO.	Head Weight	Product Weight	Length (Overall)	Type
740174	UBP-2414	24 oz	2.2 lb	14"	Ball Pein
740175	UBP-3214	32 oz	2.7 lb	14"	Ball Pein
740176	UBP-4814	48 oz	3.7 lb	14"	Ball Pein
740178	UCP-216	2 lb	4.7 lb	16"	Cross Pein
740179	UCP-316	3 lb	5.7 lb	16"	Cross Pein
740580	USH-250	2.5 lb	3.85 lb	12"	Club
740581	USH-412	4 lb	5.50 lb	12"	Sledge
740582	USH-416	4 lb	5.8 lb	16"	Sledge
740593	USH-616	6 lb	8.7 lb	16"	Sledge
740583	USH-624	6 lb	9.1 lb	24"	Sledge
740584	USH-630	6 lb	10.0 lb	30"	Sledge
740585	USH-824	8 lb	11.1 lb	24"	Sledge
740586	USH-830	8 lb	12.0 lb	30"	Sledge
740596	USH-836	8 lb	13.0 lb	36"	Sledge
740587	USH-1030	10 lb	14.5 lb	30"	Sledge
740588	USH-1230	12 lb	16.5 lb	30"	Sledge
740598	USH-1236	12 lb	17.5 lb	36"	Sledge
740589	USH-1430	14 lb	18.5 lb	30"	Sledge

## Copper Head

- Heads drop forged from 99.9% pure copper for spark free use in explosive environments
- Softer copper heads will not mar struck objects
- Ideal for coal mining, oil and gas work and other potentially flammable or explosive applications

PROD. NO.	MOD. NO.	Head Weight	Product Weight	Length (Overall)	Type
740560	USH-250C	2-1/2 lb	3.75 lb	10-3/4"	Club
740565	USH-824C	8 lb	11.1 lb	24"	Sledge
740569	USH-1430C	14 lb	18.5 lb	30"	Sledge





740522



740532

Smooth transition point between fibreglass and PVC handle for maximum comfort



740952

## SLEDGE HAMMERS

### Hickory Handle - Heavy Duty

- American hickory handles
- Forged steel heads are hardened and tempered for professional use
- Meets ANSI specifications

PROD. NO.	MOD. NO.	Product Weight	Length (Overall)
<b>740522</b>	SH-4H	<b>4 lb</b>	16"
<b>740523</b>	SH-6H	<b>6 lb</b>	32"
<b>740524</b>	SH-8H	<b>8 lb</b>	32"
<b>740525</b>	SH-10H	<b>10 lb</b>	32"
<b>740526</b>	SH-12H	<b>12 lb</b>	32"
<b>740528</b>	SH-16H	<b>16 lb</b>	36"

### Fibreglass Handle - Heavy Duty

- Highest fibreglass content for maximum strength
- Polymer jacketed to prevent splintering
- PVC grips for user comfort and safety
- Forged steel heads are hardened and tempered for professional use
- New improved bonding technology rated for use to -25°C
- Meets ANSI specifications

PROD. NO.	MOD. NO.	Head Weight	Length (Overall)
<b>740532</b>	SH-4F	<b>4 lb</b>	16"
<b>740533</b>	SH-6F	<b>6 lb</b>	30"
<b>740534</b>	SH-8F	<b>8 lb</b>	30"
<b>740535</b>	SH-10F	<b>10 lb</b>	36"
<b>740536</b>	SH-12F	<b>12 lb</b>	36"
<b>740538</b>	SH-16F	<b>16 lb</b>	36"

## DRILLING HAMMERS

### Fibreglass Handle - Heavy Duty

- Highest fibreglass content for maximum strength
- Polymer jacketed to prevent splintering
- PVC grips for user comfort and safety
- Forged steel heads are hardened and tempered for professional use
- New improved bonding technology rated for use to -25°C
- Meets ANSI specifications

PROD. NO.	MOD. NO.	Head Weight	Length (Overall)
<b>740952</b>	DH-48F	<b>3 lb</b>	10-1/2"
<b>740953</b>	DH-64F	<b>4 lb</b>	10-1/2"

# RUBBER MALLETS



## Wooden Handle

PROD. NO.	MOD. NO.	Product Weight	Length (Overall)
<b>740403</b>	RM-16	<b>1 lb</b>	13-1/4"
<b>740407</b>	RM-32	<b>2 lb</b>	13-1/2"



740912

# WELDING HAMMER

## Chipping Hammer

- Quickly removes welding flux

PROD. NO.	MOD. NO.
<b>740901</b>	FH-1



740901

# AXES AND MAULS

## Fibreglass Handle - Heavy Duty

- Highest fibreglass content for maximum strength
- Polymer jacketed to prevent splintering
- PVC grips for user comfort and safety
- Forged steel heads are hardened and tempered for professional use
- New improved bonding technology rated for use to -25°C

PROD. NO.	MOD. NO.	Head Weight	Length (Overall)	Type
<b>741107</b>	JH-150F	<b>1-1/2 lb</b>	16"	Hatchet
<b>741121</b>	JA-250F	<b>2-1/2 lb</b>	34"	Axe
<b>741123</b>	JA-350F	<b>3-1/2 lb</b>	34"	Axe
<b>741141</b>	SM-6F	<b>6 lb</b>	34"	Maul
<b>741142</b>	SM-8F	<b>8 lb</b>	34"	Maul



741107

741141

741121

**WARNING:** always wear safety goggles





740912



740926



740977

**5X** POLYURETHANE SHELL  
LIFE OF PVC

## SOFT FACE DEAD BLOW HAMMERS

### PVC Shell - Standard Duty

- Single piece body made out of PVC, filled with steel shot
- Orange colour for high visibility

PROD. NO.	MOD. NO.	Head Weight	Length (Handle)
<b>740912</b>	DB-100	<b>1 lb</b>	11-1/2"
<b>740913</b>	DB-150	<b>1-1/2 lb</b>	12-1/2"
<b>740914</b>	DB-200	<b>2 lb</b>	13-1/2"
<b>740915</b>	DB-300	<b>3 lb</b>	16"

### Polyurethane/Fibreglass - Heavy Duty

- Polyurethane is much tougher and longer lasting than PVC – up to 5 times the life
- Steel shot filled head directs full force of blow to the work preventing rebound
- Soft face will not mar work
- Steel skeleton encased in tough Polyurethane jacket (740926)
- Fibreglass handle with Polyurethane covered striking head (740927 and 740928)
- TPR handle grip for superior control and user comfort
- Temperature range of -20°C to 90°C

PROD. NO.	MOD. NO.	Head Weight	Length (Overall)
<b>740926</b>	DB-400HD	<b>4 lb</b>	12"
<b>740927</b>	DB-600HD	<b>6 lb</b>	32"
<b>740928</b>	DB-800HD	<b>8 lb</b>	32"

### Polyurethane Shell - Super Heavy Duty

- One piece oven cured polyurethane shell is much tougher than PVC, plastic, or rubber – up to 5 times the life
- Superior resistance to cuts, splits, abrasions and many chemicals
- One piece seamless shell allows use in non-sparking environments
- Steel shot filled head directs full force of blow to the work, preventing rebound
- Soft face will not mar surfaces
- 6 lb hammers feature flat heads to allow hammer to stand upright
- Hardness Shore A 90 ±2

PROD. NO.	MOD. NO.	Head Weight	Head Length	Face Diameter	Length (Overall)
<b>740971</b>	DBHD-16	<b>1 lb</b>	3-1/2"	1-15/32"	11"
<b>740972</b>	DBHD-24	<b>1-1/2 lb</b>	4"	1-3/4"	12"
<b>740974</b>	DBHD-36	<b>2-1/4 lb</b>	4-1/2"	2-3/16"	13-1/2"
<b>740975</b>	DBHD-48	<b>3 lb</b>	4-13/16"	2-3/8"	16-3/4"
<b>740977</b>	DBHD-96	<b>6 lb</b>	7-3/32"	2-3/4"	20"
<b>740978</b>	DBHD-168	<b>10 lb</b>	7-3/32"	2-3/4"	30"
<b>740979</b>	DBHD-190	<b>12 lb</b>	8"	3-5/32"	36-1/2"

# SOFT FACE DEAD BLOW HAMMERS



## Replaceable Tip Dead Blow - Heavy Duty

- Steel shot filled head directs full force of blow to the work preventing rebound
- Soft face will not mar work
- Welded steel construction
- Hard and soft plastic faces available separately
- TPR handle grip for superior control and user comfort

PROD. NO.	MOD. NO.	Head Weight	Handle Length	Face Diameter
<b>740932</b>	SFH-125	<b>20 oz</b>	10-1/4"	1-3/8"
<b>740933</b>	SFH-175	<b>29 oz</b>	10-1/4"	1-1/2"
<b>740934</b>	SFH-225	<b>38 oz</b>	10-1/4"	1-3/4"

## Replaceable Tips - Dead Blow

PROD. NO.	MOD. NO.	Description	Face Diameter
<b>740994</b>	RTMW-35	Medium Tip for 740932	1-3/8"
<b>740995</b>	RTMW-40	Medium Tip for 740933	1-1/2"
<b>740996</b>	RTMW-45	Medium Tip for 740934	1-3/4"
<b>740997</b>	RTSB-35	Soft Tip for 740932	1-3/8"
<b>740998</b>	RTSB-40	Soft Tip for 740933	1-1/2"
<b>740999</b>	RTSB-45	Soft Tip for 740934	1-3/4"



740933

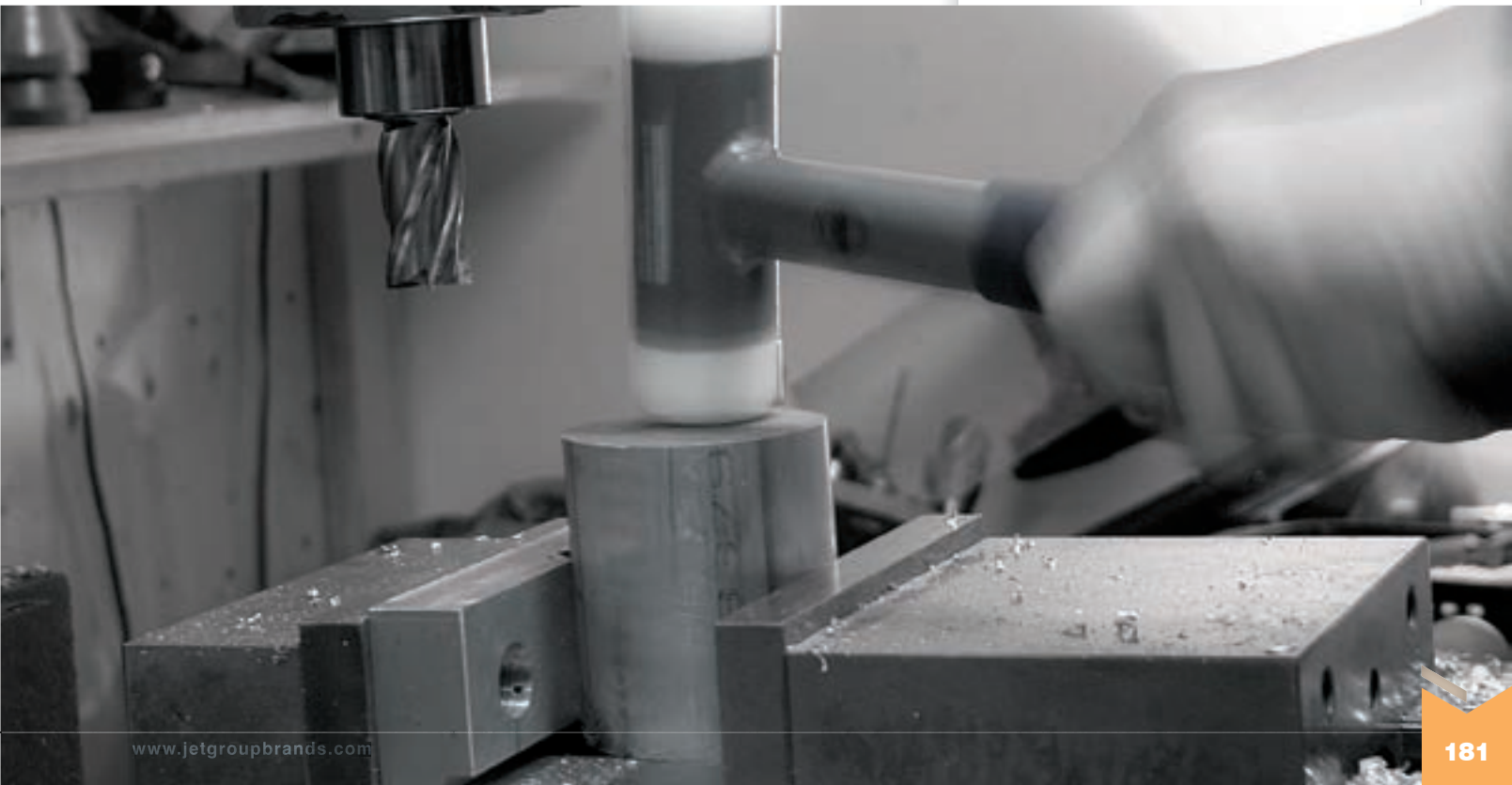



## PUNCH AND CHISEL - SETS

### ▼ Hand Tools shown in this section feature:

- Made of the highest grade carbon steel, accurately hardened and tempered preventing splintering and extending life
- Powder coated shank protects against rust
- Edges accurately tempered to stay sharp
- Extra-thick hexagonal shanks minimize roll away
- Working ends accurately ground and hardened to HRC 52-58 for maximum service
- Striking end hardened to HRC-42 maximum – won't chip or mushroom
- Meets Canadian Government Specifications CDA39GP-43a

**⚠ WARNING:** Always use punches and chisels on materials softer than the hardness of the punch itself

### 6 PC Pin Punch Set

775509 / PP-6S

- Pin Punch: **3/32, 1/8, 5/32, 3/16, 1/4, 5/16"**
- Terylene Pouch



### 6 PC Roll Pin Punch Set

775526 / RPP-6S

- Roll Pin Punch: **3/32, 1/8, 5/32, 3/16, 1/4, 5/16"**
- Terylene Pouch



### 6 PC Cold Chisel Set

775531 / CC-6S

- Cold Chisel: **1/4, 5/16, 3/8, 1/2, 5/8, 3/4"**
- Terylene Pouch



**WARNING:** always wear safety goggles 

**8 PC Punch and Chisel Set** **775507** / PC8-1S

- Cold Chisel: **1/2, 5/8, 3/4"**
- Centre Punch: **5/32"**
- Solid Punch: **3/16"**
- Pin Punch: **1/8, 3/16, 1/4"**
- **Terylene Pouch**



**14 PC Punch and Chisel Set** **775511** / PC-14S

- Cold Chisel: **3/8, 1/2, 5/8, 3/4, 7/8"**
- Centre Punch: **5/32, 1/4"**
- Solid Punch: **1/8, 5/16"**
- Drift Punch: **1/8, 5/32"**
- Pin Punch: **1/16, 1/8, 3/16"**
- **Terylene Pouch**



**16 PC Punch and Chisel Set** **775508** / PC16-1S

- Cold Chisel: **5/16, 1/2, 5/8, 3/4, 7/8"**
- Centre Punch: **1/8, 5/32, 1/4"**
- Solid Punch: **1/8, 3/16, 1/4"**
- Drift Punch: **3/16, 1/4"**
- Pin Punch: **1/8, 3/16, 1/4"**
- **Terylene Pouch**

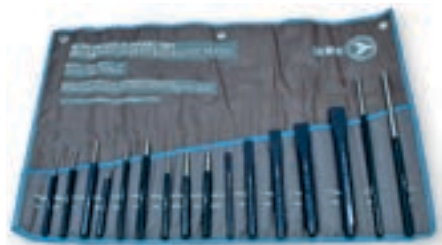

**24 PC Punch and Chisel Set** **775513** / PC24S

- Cold Chisel: **1/4, 5/16, 3/8, 1/2, 5/8, 3/4, 7/8"**
- Centre Punch: **5/64, 5/32, 1/4", ACP-2 Auto**
- Solid Punch: **1/16, 1/8, 5/32, 3/16, 1/4, 5/16"**
- Pin Punch: **1/16, 3/32, 1/8, 5/32, 3/16, 1/4, 5/16"**
- **Terylene Pouch**



**WARNING:** always wear safety goggles



## PUNCH AND CHISEL - OPEN STOCK

### ▼ Hand Tools shown in this section feature:

- Made of the highest grade carbon steel, accurately hardened and tempered preventing splintering and extending life
- Powder coated shank protects against rust
- Edges accurately tempered to stay sharp
- Extra-thick Hexagonal shanks minimize roll away
- Working ends accurately ground and hardened to HRC 52-58 for maximum service
- Striking end hardened to HRC-42 maximum – won't chip or mushroom
- Meets Canadian Government Specifications CDA39GP-43a

**⚠ WARNING:** Always use punches and chisels on materials softer than the hardness of the punch itself

### Pin Punches

- Ideal for driving out and removing already loosened pins and keys after initial movement by a solid punch

PROD. NO.	MOD. NO.	Point	Shank	Length
<b>775400</b>	PP232	<b>1/16"</b>	1/4"	4"
<b>775401</b>	PP332	<b>3/32"</b>	1/4"	4-1/4"
<b>775402</b>	PP432	<b>1/8"</b>	5/16"	4-3/4"
<b>775403</b>	PP532	<b>5/32"</b>	5/16"	5"
<b>775404</b>	PP632	<b>3/16"</b>	5/16"	5-1/4"
<b>775405</b>	PP832	<b>1/4"</b>	3/8"	5-3/4"
<b>775406</b>	PP1032	<b>5/16"</b>	7/16"	6"



### Roll Pin Punches

- Specifically designed for removing roll pins and spring pins
- Ball end keeps punch centered and allows maximum contact between pin and punch shoulder

PROD. NO.	MOD. NO.	Point	Shank	Length
<b>775452</b>	RPP332	<b>3/32"</b>	1/4"	3-1/2"
<b>775453</b>	RPP432	<b>1/8"</b>	1/4"	3-3/4"
<b>775454</b>	RPP532	<b>5/32"</b>	5/16"	4-1/2"
<b>775455</b>	RPP632	<b>3/16"</b>	5/16"	4-1/2"
<b>775456</b>	RPP832	<b>1/4"</b>	3/8"	5-1/2"
<b>775457</b>	RPP1032	<b>5/16"</b>	3/8"	6"



**WARNING:** always wear safety goggles





## Solid (Starting) Punches

- Solid (or starting) punches are used prior to using a pin punch and are useful for loosening frozen or tight pins and keys

PROD. NO.	MOD. NO.	Point	Shank	Length
<b>775420</b>	SP116	<b>1/16"</b>	3/8"	5"
<b>775421</b>	SP216	<b>1/8"</b>	5/16"	5"
<b>775422</b>	SP316	<b>3/16"</b>	3/8"	5"
<b>775423</b>	SP416	<b>1/4"</b>	1/2"	5"
<b>775424</b>	SP516	<b>5/16"</b>	1/2"	6"
<b>775425</b>	SP532	<b>5/32"</b>	3/8"	5"



## Centre Punches

- Ideal for clearly marking metal in work layout and making indentations in a workpiece before drilling
- Working tips are centered and ground to a correct 90° included angle

PROD. NO.	MOD. NO.	Point	Shank	Length
<b>775440</b>	CP416	<b>5/64"</b>	1/4"	3-1/2"
<b>775441</b>	CP516	<b>1/8"</b>	5/16"	4-1/2"
<b>775442</b>	CP616	<b>5/32"</b>	5/16"	5-1/2"
<b>775443</b>	CP816	<b>1/4"</b>	3/8"	6"



## Drift (Aligning) Punches

- Ideal for lining up holes in two or more pieces of metal and for drawing pins through various assemblies
- Often referred to as aligning punches. Pry or twist both parts into alignment and then tap gently to ensure perfect alignment

PROD. NO.	MOD. NO.	Point	Shank	Length
<b>775410</b>	AP532	<b>5/32"</b>	3/8"	9"
<b>775411</b>	AP216	<b>1/8"</b>	5/16"	8"
<b>775412</b>	AP316	<b>3/16"</b>	5/16"	10"
<b>775413</b>	AP416	<b>1/4"</b>	3/8"	10"



**WARNING:** always wear safety goggles





## PUNCH AND CHISEL - OPEN STOCK

### Cold Chisels

- Designed for cutting, shaping or removing metals softer than the chisel itself such as wrought iron, unhardened steel, aluminum, brass and copper. Can also be used on some building materials

PROD. NO.	MOD. NO.	Shank	Length	Blade Width
<b>775430</b>	CC430	1/4"	5"	1/4"
<b>775431</b>	CC516	1/4"	5"	5/16"
<b>775437</b>	CC616	5/16"	5-1/2"	3/8"
<b>775432</b>	CC816	7/16"	6"	1/2"
<b>775433</b>	CC1016	1/2"	6-1/2"	5/8"
<b>775434</b>	CC1216	5/8"	7"	3/4"
<b>775435</b>	CC1416	5/8"	8"	7/8"
<b>775436</b>	CC1616	3/4"	8-1/2"	1"



### Cold Chisels - with Safety Grips

- Safety grip protects hand from overstrikes

PROD. NO.	MOD. NO.	Length	Blade
<b>775461</b>	CCG-110	10"	1"
<b>775462</b>	CCG-112	12"	1"



### Automatic Centre Punch

- Adjustable tension controls depth of impression

PROD. NO.	MOD. NO.	Length	Diameter
<b>775592</b>	ACP-2	5"	1/2"



**WARNING:** always wear safety goggles 

# STAMPS - NUMBER / LETTER



▼ Hand Tools shown in this section feature:

- Manufactured from high quality steel and induction hardened for durability and extended life
- Stamping end hardened to 58-62 HRC – striking end hardened to 38-43 HRC to prevent splintering
- Striking ends are beveled to prevent breakage and to increase operator safety
- Sets contain: Numbers: 0 - 9 (6 and 9 are interchangeable)
- Letters: A - Z and & (ampersand)



## LS Series - Letter Stamp Sets

PROD. NO.	MOD. NO.	Pieces	Characters	Size
<b>391104</b>	LS-030	27	Letters	<b>3mm (1/8")</b>
<b>391107</b>	LS-050	27	Letters	<b>5mm (3/16")</b>
<b>391110</b>	LS-060	27	Letters	<b>6mm (1/4")</b>



## NS Series - Number Stamp Sets

PROD. NO.	MOD. NO.	Pieces	Characters	Size
<b>391103</b>	NS-030	9	Numbers	<b>3mm (1/8")</b>
<b>391106</b>	NS-050	9	Numbers	<b>5mm (3/16")</b>
<b>391109</b>	NS-060	9	Numbers	<b>6mm (1/4")</b>



**WARNING:** always wear safety goggles. 







# Construction Tools



WRECKING BARS  
BOLT CUTTERS  
MEASURING TOOLS  
STAPLERS AND TACKERS  
HACKSAWS



**POWER CLAW™**



Extra wide face and unique curve design provides more leverage with less effort



Nail puller notches on both ends

## BARS - POWERCLAW™ SERIES

▼ Hand Tools shown in this section feature:

- Canada's premier super heavy duty wrecking bars are designed for the toughest jobs
- Made of tough heat treated alloy steel rather than carbon steel
- Precision ground claws are sharper and stronger than competitive products
- Electrostatic powder coated for corrosion resistance

### Wrecking Bars – Super Heavy Duty

- Heavy duty extra thick profiled bar stock for maximum strength and leverage
- Extra wide face and unique curve radius allows greater leverage with less operator effort

PROD. NO.	MOD. NO.	Length	Material
<b>779201</b>	JPWB-14	<b>14"</b>	Alloy
<b>779203</b>	JPWB-24	<b>24"</b>	Alloy
<b>779205</b>	JPWB-36	<b>36"</b>	Alloy
<b>779256</b>	JPWB-48	<b>48"</b>	Alloy



### Wrecking Bars - Notched Style - Super Heavy Duty

- Extra tight radius on curved end for increased leverage
- Nail notches on both ends for maximum versatility
- Smooth finished oval cross section shaft for maximum comfort and pulling power

PROD. NO.	MOD. NO.	Length	Material
<b>779252</b>	JPNB-18	<b>18"</b>	Alloy
<b>779253</b>	JPNB-24	<b>24"</b>	Alloy
<b>779255</b>	JPNB-36	<b>36"</b>	Alloy



## Hammerhead Wrecking Bars - Super Heavy Duty

- Patented design features extra long claw and reinforced hammer face
- Hammer face is ideal for aligning boards, demolition work, and driving claw into tight spaces
- Extra wide claws minimize side rolling for stable lifting and prying
- Specially designed angle allows bar to be used close to work and provides tremendous leverage
- Drop forged steel with I beam profile for maximum strength
- Nail puller notch in claw
- Available with dual claws or TPR grip handle



### Dual Claw

PROD. NO.	MOD. NO.	Length	Claws
<b>779261</b>	JHHB-17	<b>17"</b>	2
<b>779262</b>	JHHB-36	<b>36"</b>	2



779261

### Single Claw TPR Grip Handle Style

- Same great features except grip adds hand protection for more leverage and allows bar to be hung on wall or from tool belt



PROD. NO.	MOD. NO.	Length	Claws	Material
<b>779263</b>	JHHB-17H	<b>17"</b>	1	Alloy
<b>779264</b>	JHHB-36H	<b>36"</b>	1	Alloy

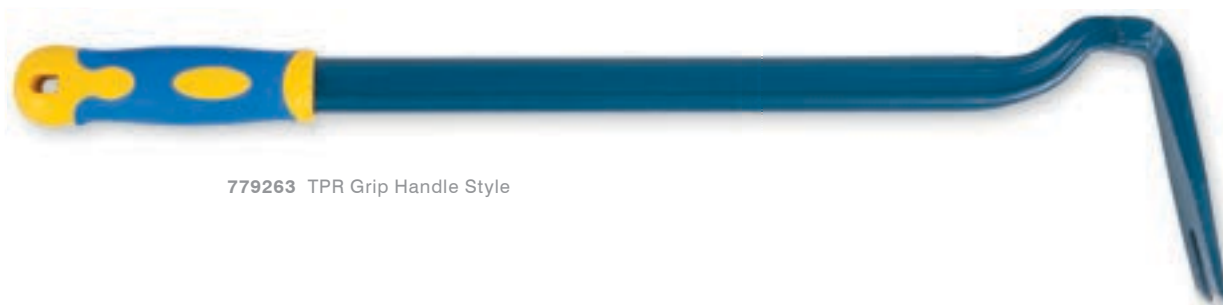

779263 TPR Grip Handle Style



## BARS - POWERCLAW™ SERIES

▼ Hand Tools shown in this section feature:

- Canada's premier super heavy duty wrecking bars are designed for the toughest jobs
- Made of tough heat treated alloy steel rather than carbon steel
- Precision ground claws are sharper and stronger than competitive products
- Electrostatic powder coated for corrosion resistance

### Pinch Bars - Hex Shank - Super Heavy Duty

- Hex shaft bars for maximum comfort
- Pencil and chisel points for a variety of tasks

PROD. NO.	MOD. NO.	Length	Shank Size	Material
779211	JPPB-18	18"	3/4"	Alloy
779212	JPPB-24	24"	3/4"	Alloy
779213	JPPB-30	30"	3/4"	Alloy
779214	JPPB-36	36"	3/4"	Alloy
779215	JPPB-48	48"	1"	Alloy
779216	JPPB-60	60"	1"	Alloy



### Ironworker's Pinch Bars - Round Shank Super Heavy Duty

- Drop forged chrome alloy steel bars for professional use
- Individually magnetic particle tested to ensure complete material integrity
- Entirely heat treated, not just at the working ends, for maximum endurance
- Smooth taper assists in lining up bolt holes
- Fully chrome plated to resist corrosion

PROD. NO.	MOD. NO.	Length	Shank Size	Material
779231	JIWB-18	18"	5/8"	Chrome Alloy
779232	JIWB-24	24"	3/4"	Chrome Alloy
779233	JIWB-30	30"	7/8"	Chrome Alloy
779234	JIWB-36	36"	7/8"	Chrome Alloy



779211 - 779216 Hex Shank Pinch Bar



779231 - 779234 Round Shank Pinch Bar

### Crow Bar - Super Heavy Duty

- Massive bar stock provides maximum strength for heavy prying and lifting jobs

PROD. NO.	MOD. NO.	Length	Weight	Material
779218	JPCB-1860	60"	18 lbs	Alloy



### Digging Bar - Super Heavy Duty

- Pencil point and chisel point for breaking hard packed ground
- Heavy duty bar stock provides maximum leverage for moving rocks

PROD. NO.	MOD. NO.	Length	Shank Size	Weight	Material
779258	JPDB-1772	72"	1"	17 lbs	Alloy



779218 **60"**



779258 **72"**





## Utility Bar

PROD. NO.	MOD. NO.	Length	Material
779112	PB-15	15"	Alloy



779112

## Nail Puller

PROD. NO.	MOD. NO.	Length	Material
779113	JPNP-11	11"	Alloy



779113



## 4 PC Rolling Head Pry Bar Set

859211 / JRPB-4S

- Rounded head acts as a fulcrum to provide extra leverage
- Tapered point and round stock ideal for aligning parts through bolt holes
- Heat treated Chrome Vanadium steel for professional use
- Magnetic particle tested to ensure complete material integrity
- Electrostatic powder coat paint protects against corrosion
- Includes: **6, 12, 16, 20"**



## Rolling Head Pry Bars - Open Stock

PROD. NO.	Length	Contained in Set
859212	6"	859211
859213	12"	859211
859214	16"	859211
859215	20"	859211

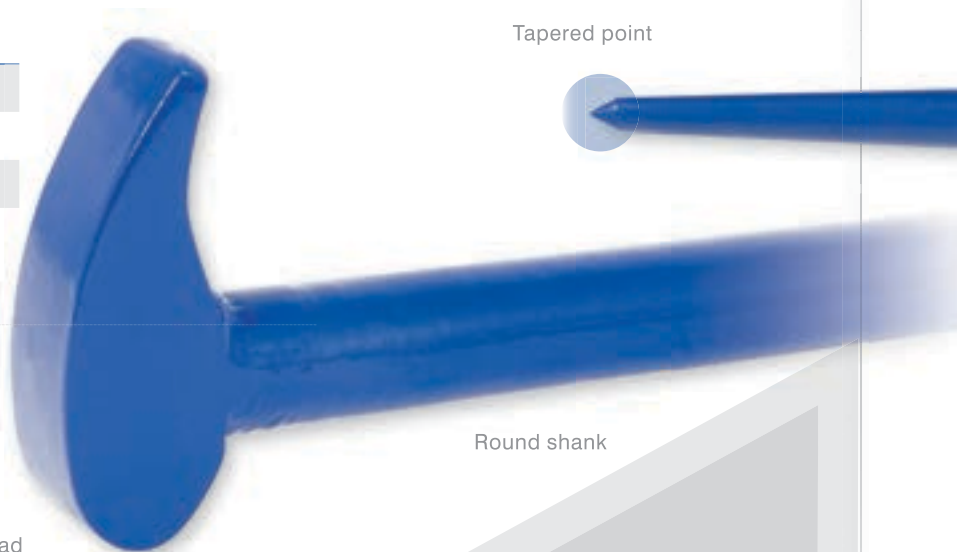

Rounded head

Round shank

Tapered point

**MECHANIC'S PRY BARS**  
See page 321 for Mechanic's  
Pry Bars



731108



731114

**NEW**

**SHD**



731238

## BOLT & ROD CUTTERS

### Bolt Cutters - Heavy Duty

- JET bolt cutters are designed to cut soft and medium grade bolts, rods, rivets, bar and chain
- Serrated cutting edges cut with less hand force and prevent material from slipping
- **Chrome Molybdenum** steel blades
- Blades hardened to HRC 55 - 61
- Maximum hardness of material to be cut: HRC 40

PROD. NO.	MOD. NO.	Length	Capacity (Soft)	Capacity (Medium)	Replacement Head
<b>731108</b>	BC-8	<b>8"</b>	—	—	—
<b>731112</b>	BC-12	<b>12"</b>	3/16"	5/32"	<b>731162</b>
<b>731114</b>	BC-14	<b>14"</b>	1/4"	3/16"	<b>731164</b>
<b>731118</b>	BC-18	<b>18"</b>	5/16"	1/4"	<b>731168</b>
<b>731124</b>	BC-24	<b>24"</b>	3/8"	5/16"	<b>731174</b>
<b>731130</b>	BC-30	<b>30"</b>	1/2"	5/16"	<b>731180</b>
<b>731136</b>	BC-36	<b>36"</b>	5/8"	3/8"	<b>731186</b>
<b>731142</b>	BC-42	<b>42"</b>	3/4"	7/16"	<b>731192</b>

CrMo

## BOLT & ROD CUTTERS

### High Tensile Bolt Cutters – Super Heavy Duty

- Drop forged Chrome Vanadium steel blades specially hardened for use on high tensile steel bolts, rod, and chain
- Induction hardened and quenched cutting edges are suitable for cutting materials up to HRC 48
- Cutting head painted red to designate high tensile cutting ability
- Drop forged adaptor and heat treated handles for maximum strength
- Powder coated for resistance to corrosion
- Meets US Federal Government Specification GGG-C-740d Type II Class 3 & 4

PROD. NO.	MOD. NO.	Length	Capacity (Soft)	Capacity (Medium)	Replacement Head
<b>731238</b>	BCR-18	<b>18"</b>	5/16"	1/4"	<b>731278</b>
<b>731244</b>	BCR-24	<b>24"</b>	3/8"	5/16"	<b>731284</b>
<b>731256</b>	BCR-36	<b>36"</b>	5/8"	15/32"	<b>731296</b>

CrV

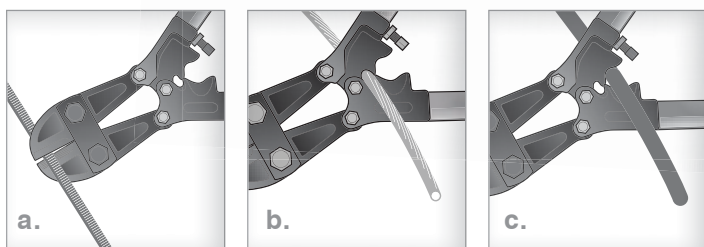

Bolt Wire Rope Cable

### 3-in-1 Bolt Cutters

- Unique design cuts bolts, rods, wire and cable
- Hardened drop forged Chrome Vanadium blades for long life
- Serrated cutting edges cut with less hand force and prevent material from slipping
- Bolt cutter blades are easily adjustable and replaceable
- Blade hardness HRC55 – 60
- Maximum material hardness HRC 42

PROD. NO.	MOD. NO.	Size	Bolt	Rebar	Wire Rope	Cable	Replacement Head
731204	BCW-18	18"	5/16"	1/4"	3/16"	3/8"	731214
731205	BCW-24	24"	13/32"	5/16"	9/32"	1/2"	731215



### Rod Cutter and Bender

- A premium industrial quality rod cutter / bender for heavy duty construction applications
- Bends 5/8" rebar up to 180°

PROD. NO.	MOD. NO.	Capacity	Replacement Head
735403	RC-16	5/8"	731453



## MEASURING TOOLS

### Tape Measures - Heavy Duty

- Extra wide tape provides 8' standout
- High contrast blade for easy reading
- 1/16" increments on S.A.E. scale
- Integral rubber inserts provide maximum grip and protection
- Built-in bumper cushions recoil impact
- Easy slide lock
- Meets GS / TUV and CE standards
- Available individually carded or in display case of 12 carded tapes



PROD. NO.	MOD. NO.	Scale	Width	Overall Length
<b>775921</b>	JTM-416SM	S.A.E./Metric	1"	<b>16' / 5m</b>
<b>775928</b>	JTM-425S	S.A.E.	1"	<b>25'</b>
<b>775929</b>	JTM-425SM	S.A.E./Metric	1"	<b>25' / 7.5m</b>

### Extra Long Steel Tape Measure

**775936** / JSTM-100SM

- Two sided tape features S.A.E. measurements on one side, Metric on the other
- Fast rewind provided by fold-away handle
- High contrast blade for easy reading
- 0 point inside ring
- Meets GS / TUV and CE standards
- 3/8" width
- 100' / 30m length

### Open Reel Fibreglass Tape Measure

**775910** / JFTM-165SM

- Two sided tape features S.A.E. measurements on one side, Metric on the other
- Fast rewind provided by fold-away handle
- 0 point inside ring
- PVC coating prevents rot, facilitates cleaning - can be rewound when wet
- Ergonomic case with sure grip
- Tape can be removed and rewound to show either scale face up
- Meets GS / TUV and CE standards
- 1/2" width
- 165' / 50m length

## Framing and Layout Square

- Lacquer coated steel squares resist rust
- Clear permanently etched graduations
- 1/8" increments on all edges
- Rafter square has brace scale and rafter table

PROD. NO.	MOD. NO.	Scale	Blade	Tongue
<b>776055</b>	JSCS-812	S.A.E.	<b>1-1/2" x 12"</b>	1" x 8"
<b>776060</b>	JSRS-1624	S.A.E.	<b>2" x 24"</b>	1-1/2 x 16"



776060

## Rafter Angle Square

**776061** / JRAS-710

- Extra thick aluminum extrusion is stronger than brittle die casts
- Will not rust
- Clear permanently etched graduations
- Measures hip, valley and common rafter angles
- Most versatile square – combines rafter and framing square, protractor, try square, mitre square and saw guide
- **7" x 7" x 10"**
- Scale S.A.E.



## Combination Square

**776065** / JCS-12

- Die cast aluminum head for accuracy and durability
- Stainless steel blade with etched graduations
- S.A.E. scale on all edges allows marking on both sides of blade
- Built in level for improved accuracy and versatility
- Convenient scratch awl
- Meets GS / TUV and CE standards
- Blade: **1" x 12"**



## T-Bevel Square

**776070** / JTB-8

- Use to measure and transfer angles
- S.A.E. and Metric graduations
- Built in level for improved accuracy and versatility
- Large knurled locking wheel will not jam
- Steel blade with ABS handle
- Meets GS / TUV and CE standards
- Blade: **2" x 8"**





## MEASURING TOOLS

### Aluminum Box Levels

- Box beam construction with reinforcing ribs prevents twisting and bending under normal use
- Precision milled on both surfaces for maximum accuracy
- 3 shatter-resistant acrylic block vials read horizontal, plumb and 45°
- Top read centre vial provides 300° viewing for easy readability
- Oversized hand holes for sure grip
- Shock absorbing beveled end caps
- Bright yellow finish for improved visibility
- Meets GS / TUV and CE standards

Top read centre vial



776001

PROD. NO.	MOD. NO.	Overall Length	Vials
<b>776001</b>	JBL-9924B	<b>24"</b>	3
<b>776002</b>	JBL-9948B	<b>48"</b>	3
<b>776004</b>	JBL-9972B	<b>72"</b>	3

### Aluminum Box Levels - Heavy Duty

- Extra thick aluminum stock extruded into a unique profile offers the ultimate in strength and resistance to twisting
- Precision milled on both surfaces for maximum accuracy
- V-grooves on both surfaces for use on pipe
- Hidden magnets in bottom surface hold level securely to metal objects
- 3 shatter-resistant mono block acrylic vials (1 horizontal, 2 plumb)
- Top read centre vial provides 300° visibility
- Double layer rubber and plastic end caps offer superior shock absorption
- Meets GS/TUV and CE standards

Top read centre vial



776021

PROD. NO.	MOD. NO.	Overall Length	Vials
<b>776021</b>	JPBL-24	<b>24"</b>	3
<b>776022</b>	JPBL-48	<b>48"</b>	3

**Torpedo Level** 776006 / JTL-9B

- 9" aluminum frame for improved accuracy and durability
- Top read centre vial for easy readability, provides 300° viewing
- 3 vials read horizontal, plumb and 45°
- White frame around vials for improved readability
- Magnetic strip holds level securely to metal objects
- Meets GS / TUV and CE standards



**Chalk Line Set** 779161 / JACL-100S

- Aluminum case for maximum durability
- Holds 100' of line
- Can be used as a plumb bob
- Includes 3" line level and 4 oz. chalk



**Replacement Chalk** 779162 / JBPC-4

- 4 oz. fine blue layout chalk
- For use with any chalk line reel



**Plumb Bob - Brass** 779171 / JBPB-12

- 12 oz. solid machined brass
- Hardened steel replaceable tip
- Extra tip included
- Top unscrews for easy line centering





849403

849411

## STAPLERS AND TACKERS

▼ *Hand Tools shown in this section feature:*

- JET staplers and hammer tackers are designed for professional use
- Durable all steel or aluminum construction
- Nickel plated finish resists corrosion
- Low staple viewing window
- Handle lock allows compact storage

### Staple Guns

#### Standard Duty

**849403** / JSG-103

- Exclusive swing-away channel for easy clearing of jammed staples
- Perfect for light to medium duty applications
- Uses **1/4" – 5/16" Standard Duty JET staples** or equivalents

#### Heavy Duty

**849411** / JSG-101HD

- Comfortable PVC hand grip
- For upholstery, fencing, carpeting, ceiling tile, insulation and many other uses
- Uses **1/4" – 9/16" Heavy Duty JET staples** or equivalents

#### Staple / Nail Gun - Heavy Duty

**849412** / JSG-102HD

- Die cast aluminum alloy housing will not rust
- Ergonomic design allows application of maximum pressure without fatigue
- 2 position adjustment lever provides the ideal power for use on soft or hard materials
- Bi-material hand grip for increased comfort
- Bottom loading design for fast refills and easy clearing of jammed staples
- For upholstery, fencing, carpeting, ceiling tile, insulation and many other uses
- Unique lock allows compact storage
- Uses **1/4" – 9/16" Heavy Duty JET staples** or equivalents and **18 gauge brad nails**
- Low staple viewing window





## Hammer Tackers

### Standard Duty

849407 / JHT-102

- Perfect for light to medium applications
- Large PVC grip for maximum comfort
- Uses **1/4" – 5/16" Standard Duty JET staples** or equivalent

### Heavy Duty

849416 / JHT-101HD

- 32 oz total weight provides maximum hitting power
- Ideal for carpet and underlay, roofing felt, plastic sheeting etc.
- Comfortable rubber handle for maximum grip
- Rear loading magazine
- Uses **1/4" – 3/8" Heavy Duty JET staples** or equivalents

## Staples

- Designed for use with JET staplers or any brand compatible with Arrow® T-50 or JT-21 staplers
- 1,000 staples per box
- Available in various lengths from 1/4" to 9/16"
- Available for standard duty and heavy duty applications

PROD. NO.	MOD. NO.	Description	Use With Models
849481	JS-1006	1/4" SD Staples	849403 (JSG-103) 849407 (JHT-102)
849482	JS-1008	5/16" SD Staples	849403 (JSG-103)
849491	JS-1006HD	1/4" HD Staples	849411 (JSG-101HD) 849412 (JSG-102HD) 849416 (JHT101HD)
849492	JS-1008HD	5/16" HD Staples	849411 (JSG-101HD) 849412 (JSG-102HD) 849416 (JHT101HD)
849493	JS-1010HD	3/8" HD Staples	849411 (JSG-101HD) 849412 (JSG-102HD) 849416 (JHT101HD)
849494	JS-1012HD	1/2" HD Staples	849411 (JSG-101HD) 849412 (JSG-102HD)
849495	JS-1014HD	9/16" HD Staples	849411 (JSG-101HD) 849412 (JSG-102HD)



849416

849407



Arrow® is a trademark of Arrow Fastener Co. Inc.



12" Blades



12" Blades



12" Blades



6" Blades

## HACKSAWS FRAMES

▼ *Hand Tools shown in this section feature:*

- Cast aluminum frames combine high strength with light weight
- TPR grip on handle for comfort and secure grip
- Blade can be angle mounted for special applications
- Powder coated for added resistance to corrosion

### 12" Ergonomic Frame

**775306** / 525A

- Heavy ergonomic frame accepts 12" blades
- Front frame with contoured grip for better control
- Convenient in handle blade storage

### 12" Oval Tube Style – Heavy Duty

**775307** / JHS-5012

- Oval tube provides greater strength than square tube saws
- Extra thick cast aluminum frame components for heavy duty professional applications
- Easy to use wing nut provides up to 3,000 PSI tension on blade
- Blade can be mounted at 45° for special applications
- Unique blade storage compartment holds up to 6 spare blades

### 12" Aluminum I-Beam Style

**775308** / JHS-3012

- One piece cast aluminum I-beam frame for rigidity
- Easy to use wing nut provides up to 2,500 PSI tension on blade
- Blade can be mounted at 45° for special applications

### 6" Mini Aluminum I-Beam Style

**775301** / JHS-9006

- One piece cast aluminum I-beam frame for rigidity
- 10-1/4" overall length - fits in any tool box
- Thumbscrew tension adjustment
- Blade can be mounted at 60° left or right
- Uses 6" mini hacksaw blades with mounting pins
- Replacement blade: **775391**

## JET-KUT® Bi-Metal Hacksaw Blades

- Bi-metal construction with carbon steel core and high speed steel teeth thermally treated under high vacuum
- Flexible and shatterproof safety blades
- An excellent performing, long lasting blade for a wide range of applications

PROD. NO.	Size (inches) L x W x T	Teeth TPI	Pkg Qty
<b>566231</b>	12 x 1/2 x 0.25	<b>18</b>	10 / 100
<b>566232</b>	12 x 1/2 x 0.25	<b>24</b>	10 / 100
<b>566233</b>	12 x 1/2 x 0.25	<b>32</b>	10 / 100

WIRE WHEELS AND CUTTING TOOLS

Please consult our Abrasives catalogue or visit our website at [www.jetgroupbrands.com](http://www.jetgroupbrands.com)





## Shop Equipment

C-CLAMPS  
L-CLAMPS  
SPRING HAND CLAMPS  
PIPE CLAMP  
VISES  
PALLET TRUCK  
LIFT HAND CART  
CREEPERS  
ROLLER SEATS  
ANTI-FATIGUE MATS

# C-CLAMPS



Mini Size Clamps



## CCJ Series Junior C-Clamps

- Drop forged steel frames for maximum strength in a minimum size
- Powder coated frames and zinc plated screws resist corrosion
- Narrow frames allow use in the most confined spaces
- Swivel pads adopt correct angle for maximum pressure

PROD. NO.	MOD. NO.	Maximum Opening	Throat Depth	Clamping Pressure (lbs)
<b>390151</b>	CCJ-100	<b>1"</b>	1"	500
<b>390153</b>	CCJ-150	<b>1-1/2"</b>	1-1/2"	850
<b>390155</b>	CCJ-200	<b>2"</b>	1-1/4"	875
<b>390157</b>	CCJ-300	<b>3"</b>	1-3/8"	850

## CSG Series

- SG Cast Iron clamps with Spheroidal Graphite structure produces 60,000 PSI tensile strength – twice the tensile strength of ductile iron clamps!
- Guaranteed unbreakable during normal use
- Reinforced frame corners
- Cross handle designed to bend before the frame can be over stressed
- Acme threaded screw for smooth operation and even clamping pressure
- Black oxide coated screw and handle resists weld spatter and corrosion

PROD. NO.	MOD. NO.	Maximum Opening	Throat Depth	Clamping Pressure (lbs)
<b>390142</b>	CSG-4	<b>4"</b>	2-11/32"	2,640
<b>390143</b>	CSG-6	<b>6"</b>	3"	2,860
<b>390144</b>	CSG-8	<b>8"</b>	3-1/8"	2,640
<b>390145</b>	CSG-10	<b>10"</b>	3-1/2"	2,530
<b>390146</b>	CSG-12	<b>12"</b>	4"	2,530

## CC Series - Regular Throat Clamps - Heavy Duty

- Industrial quality drop forged heat treated steel C-clamps
- Heavy duty swivel pads are secured by a special retaining clip that is superior to crimped pads
- Acme threaded screw for smooth operation and even clamping pressure
- Black oxide screw resists welding spatter

PROD. NO.	MOD. NO.	Maximum Opening	Throat Depth	Clamping Pressure (lbs)
<b>390102</b>	CC-2	<b>2-3/16"</b>	1"	3,300
<b>390103</b>	CC-3	<b>2-5/8"</b>	1-1/2"	4,350
<b>390104</b>	CC-4	<b>4"</b>	1-3/4"	5,300
<b>390105</b>	CC-5	<b>4-5/8"</b>	2-1/16"	5,900
<b>390106</b>	CC-6	<b>6-1/4"</b>	2-1/2"	7,650
<b>390108</b>	CC-8	<b>7-1/2"</b>	3-1/4"	8,850
<b>390110</b>	CC-10	<b>9-1/2"</b>	4-1/4"	9,000
<b>390112</b>	CC-12	<b>11-9/16"</b>	4-1/2"	13,000



## CC-D Series - Deep Throat Clamps - Heavy Duty

- Industrial quality drop forged heat treated steel C-clamps
- Extra deep throat depths for maximum versatility
- Smooth acting Acme threaded screws for maximum clamping force
- Black oxide coated screw and pads minimize splatter adhesion
- Special pad retaining clips are superior to crimped pads
- Unique clamp profile provides incredible strength yet is lighter than most competing models
- Ideal for all welding and clamping applications

PROD. NO.	MOD. NO.	Maximum Opening	Throat Depth	Clamping Pressure (lbs)
<b>390122</b>	CC-2D	<b>2-1/8"</b>	2-1/4"	3,500
<b>390123</b>	CC-3D	<b>3"</b>	2-1/2"	3,500
<b>390124</b>	CC-4D	<b>4-1/4"</b>	3-1/4"	6,200
<b>390125</b>	CC-6D	<b>6-1/16"</b>	4-1/8"	6,600
<b>390126</b>	CC-8D	<b>8-1/4"</b>	5"	6,900
<b>390127</b>	CC-10D	<b>10-1/8"</b>	6"	8,000
<b>390129</b>	CC-12D	<b>12-1/4"</b>	6-5/16"	9,300





390202



390224

## L-CLAMPS

### ▼ Hand Tools in this section feature:

- Tempered drop forged sliding arm reduces clamping set up time – ideal for high volume production work
- Nickel-chrome plated rails are heat formed from cold drawn profiled steel
- Extra deep throats for maximum versatility
- High carbon Acme threaded spindle is spatter resistant
- Rails, sliding arms, and spindles 100% heat treated
- Replaceable spindles and pads
- Specialized pads available for JLHD and JLSD Series

### JLRD Series - L-Clamps

- Increased clamping pressure and larger sizes for a wider range of applications
- Standard swivel pads

PROD. NO.	MOD. NO.	Opening	Throat Depth	Rail Size	Clamping Pressure (lbs)
<b>390202</b>	JLRD-6	<b>6"</b>	4-3/4"	1-3/16 x 9/16"	2,640
<b>390204</b>	JLRD-8	<b>8"</b>	4-3/4"	1-3/16 x 9/16"	2,640
<b>390206</b>	JLRD-10	<b>10"</b>	4-3/4"	1-3/16 x 9/16"	2,640
<b>390208</b>	JLRD-12	<b>12"</b>	5-1/2"	1-3/16 x 9/16"	2,640
<b>390210</b>	JLRD-16	<b>16"</b>	4-3/4"	1-3/16 x 9/16"	2,640
<b>390212</b>	JLRD-20	<b>20"</b>	4-3/4"	1-3/16 x 9/16"	2,640

### JLHD Series Deep Throat Clamps - Heavy Duty

- Increased throat depth and heavy duty cold forged swivel pads
- Pads tilt to 35°
- Serrated and V-pads available for special applications

PROD. NO.	MOD. NO.	Opening	Throat Depth	Rail Size	Clamping Pressure (lbs)
<b>390224</b>	JLHD-8	<b>8"</b>	5-1/2"	1-3/16 x 9/16"	2,640
<b>390226</b>	JLHD-10	<b>10"</b>	5-1/2"	1-3/16 x 9/16"	2,640
<b>390228</b>	JLHD-12	<b>12"</b>	5-1/2"	1-3/16 x 9/16"	2,640
<b>390230</b>	JLHD-16	<b>16"</b>	5-1/2"	1-3/16 x 9/16"	2,640
<b>390232</b>	JLHD-20	<b>20"</b>	5-1/2"	1-3/16 x 9/16"	2,640
<b>390233</b>	JLHD-24	<b>24"</b>	5-1/2"	1-3/16" x 9/16"	2,640

# L-CLAMPS



## JLSD Series - Deep Throat Clamps - Super Heavy Duty

- The ultimate in depth and strength
- 45% greater clamping pressure than our heavy duty clamps
- Serrated and V-pads available for special applications

PROD. NO.	MOD. NO.	Opening	Throat Depth	Rail Size	Clamping Pressure (lbs)
390248	JLSD-12	12"	6-3/4"	1-9/16 x 3/4"	4,840
390250	JLSD-16	16"	6-3/4"	1-9/16 x 3/4"	4,840
390252	JLSD-20	20"	6-3/4"	1-9/16 x 3/4"	4,840
390254	JLSD-24	24"	6-3/4"	1-9/16 x 3/4"	4,840



### L-Clamp Accessories

- Replacement parts for L-Clamps

PROD. NO.	Description
390289	Plain Pad for 6" JLRD Clamp
390290	Screw & Handle for 6" JLRD Clamp
390291	Plain Pad for JLRD L-Clamp
390292	Plain Pad for JLHD/JLSD L-Clamp
390293	Serrated Pad for JLHD/JLSD L-Clamp
390294	V Pad for JLHD/JLSD L-Clamp

PROD. NO.	Description
390295	Screw & Handle for JLRD L-Clamp
390296	Screw & Handle for JLHD L-Clamp
390297	Screw & Handle for JLSD L-Clamp
390298	Nut for JLHD/JLSD L-Clamp
390299	Ball Joint for JLHD/JLSD L-Clamp



## PIPE CLAMPS

### JPC Series - Pipe - Heavy Duty

390482 / JPC-7500

Flat base allows stable support on work bench and allows handle to turn without contacting surface.

- Uses standard 3/4" threaded pipe (not included)
- Flat base allows clamp to stand on work bench for stable support
- Clamp height allows full turn of handle without contacting work surface
- Non-marring pads protect work from damage

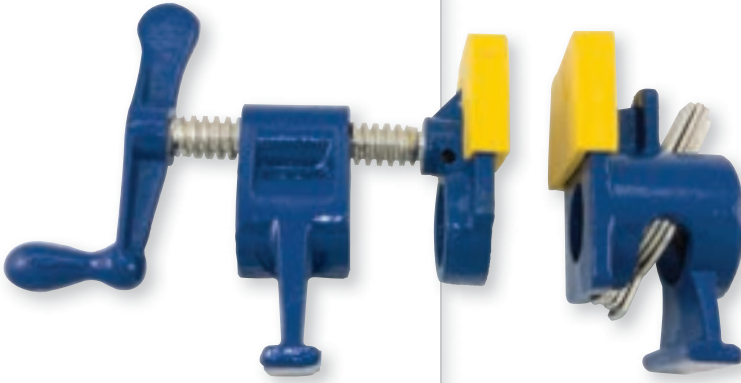

## SPRING HAND CLAMPS

### JNSC Series - Nylon Woodworking

- Reinforced nylon construction for strength
- Nylon clamps will not rust
- Tilting pads adapt to various shapes



PROD. NO.	MOD. NO.	Nominal Opening	Overall Length
390452	JNSC-4	1"	4"
390453	JNSC-6	2"	6"

### JSSC Series - Steel Woodworking

- Nickel plated to resist corrosion
- Vinyl grips for sure hold
- Use anywhere moderate clamping pressure is required



PROD. NO.	MOD. NO.	Nominal Opening	Overall Length
390457	JSSC-4	1"	4"
390458	JSSC-6	2"	6"



# VICES

Precision machined  
hardened steel jaws

## JSV Series Swivel Vise – Heavy Duty

- Class 30 iron, 30,000 lb tensile strength castings
- Precision machined hardened steel jaws (replaceable)
- Built-in pipe jaws
- Machine ground anvil surface
- 360° swivel base with dual lock down handles
- Shot blast finish powder coat paint for protection from corrosion

PROD. NO.	MOD. NO.	Jaw Width	Maximum Opening	Throat Depth	Pipe Capacity	Product Weight
<b>320151</b>	JSV-4HD	<b>4"</b>	4"	2-3/4"	1-1/2"	23 lb (10 kg)
<b>320152</b>	JSV-5HD	<b>5"</b>	5"	3-3/4"	2"	31 lbs (14 kg)
<b>320153</b>	JSV-6HD	<b>6"</b>	6"	4"	2-1/2"	45 lb (20 kg)
<b>320154</b>	JSV-8HD	<b>8"</b>	8"	4"	3-1/2"	70 lb (31.5 kg)



320154



**NEW**



320312



320316

## VICES

### SG Iron Series - Super Heavy Duty

- Strongest cast vise on the market
- Massive castings made of superior quality 80,000 PSI tensile strength SG iron for maximum strength and impact resistance
- Spheroidal graphite (SG) iron forms a much stronger molecular structure than regular cast iron
- Up to 30% higher tensile strength than competing ductile iron vises
- Precision machined hardened steel jaws
- Polished ACME threaded screw for smooth operation and maximum strength
- Sliding beam is accurately machined on all sides for smooth operation
- Enclosed at the back to protect screw from dirt and debris
- Shot blast finish powder coat paint for protection from corrosion
- Optional 360° swivel base with dual lock down handles

PROD. NO.	MOD. NO.	Jaw Width	Maximum Opening	Throat Depth	Product Weight
<b>320312</b>	JVSG-4	4"	4-5/8"	2-3/4"	31 lb (14 kg)
<b>320313</b>	JVSG-5	5"	7-1/16"	3-11/32"	51 lb (23 kg)
<b>320314</b>	JVSG-6	6"	7-7/8"	3-1/2"	73 lb (33 kg)
<b>320315</b>	JVSG-8	8"	8-7/8"	4-3/32"	88 lb (39-1/2 kg)

### Swivel Base for SG Iron Vise - Super Heavy Duty

- Swivel base converts standard JVSG vises to swivel operation for added versatility
- Powerful dual locking handles keep vise in place
- Made of the same SG ductile cast iron as the vise for maximum strength

PROD. NO.	MOD. NO.	Size	Product Weight
<b>320316</b>	JVSG-4	4"	6 lb (2.7 kg)
<b>320317</b>	JVSG-5	5"	9.9 lb (4.45 kg)
<b>320318</b>	JVSG-6	6"	13.8 lb (6.21 kg)
<b>320319</b>	JVSG-8	8"	17.4 lb (7.83 kg)



## MPV Series Multi-Purpose Vise - Heavy Duty

- Class 30 iron, 30,000 lb tensile strength castings
- Precision machined heavy duty steel jaws (replaceable)
- Jaws can be locked at any angle
- Index scale allows accurate adjustment of jaw angle
- 360° swivel base with dual lock down handles

PROD. NO.	MOD. NO.	Jaw Width	Maximum Opening	Throat Depth	Pipe Capacity	Product Weight
<b>321336</b>	MPV-125S	<b>5"</b>	4-11/16"	3"	3"	46 lb (20 kg)

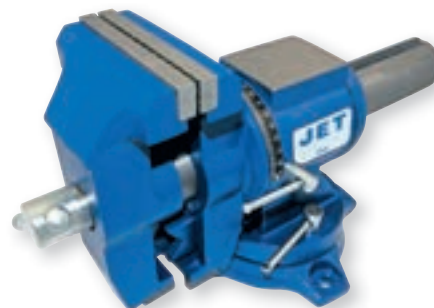

## DPV Series - Drill Press Vise - Heavy Duty

- Accurately ground base and slides
- Uni-grip mechanism allows powerful clamping force with minimal effort
- Eliminates need for crossbars or drop away handles
- Replaceable jaws hold round objects with ease

PROD. NO.	MOD. NO.	Jaw Width	Maximum Opening	Jaw Depth
<b>321124</b>	DPV-4U	<b>4"</b>	3-1/2"	1-3/16"

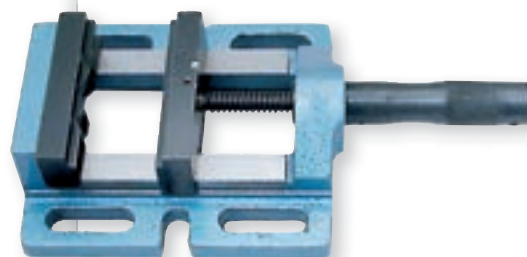



# PALLET TRUCK

## PT Series – Heavy Duty

- High quality 5,500 lb capacity
- High tensile steel frame and one piece “C” section forks with welded reinforcement for superior strength
- 3 position control lever automatically returns to neutral position
- Handle operates from rear and sides and returns to upright position when released
- Ergonomic handle grip for operator comfort and positive control
- Entry rollers in front of load rollers allow easy entry and exit from pallets
- Totally sealed hydraulic pump for reliable leak-free operation
- Built-in overload protection and top of stroke bypass valve prevents damage
- Slow lowering hand control valve for optimum control
- Large diameter polyurethane coated steel steer wheels and polyurethane load rollers for maximum manoeuvrability and smooth transport of heavy loads
- Steering column swivels 202°
- Fully adjustable push rods for fork height adjustment
- 27" x 48" forks are extra wide for maximum strength
- Grease fittings at all key points

**HEAVY LIFTING**  
See our Material Handling catalogue  
for similar products



PROD. NO.	MOD. NO.	Rated Lifting Capacity (lbs)	Skid Quantity	W1	W2	L1	L2	H1	H2	A	B	Product Weight (lb/kg)
190918	PT-5500	5,500	6	27"	7"	48"	61-1/2"	7-1/4"	2-31/32"	7-7/8" x 2-1/2"	2-29/32" x 3-55/64"	209 lb (95 kg)



Totally sealed H.D. hydraulic unit



Three position control lever for operator convenience



Heavy duty single front wheel with entry, exit roller wheel



Fully adjustable push rods

# SCISSOR LIFT HAND CART



## SLC Series – Heavy Duty

- Hydraulic table designed for lifting and lowering
- Foot pedal for easy table lifting
- Wire control for convenient operation is superior to knob control
- Large table size
- Wheel stops for positioning cart
- Polyurethane casters for smooth travel
- Industrial quality



PROD. NO.	MOD. NO.	Rated Lifting Capacity (lbs)	Minimum Table Height	Maximum Table Height	Handle Height	Table Dimensions	Wheel Diameter	Foot Pedal Cycles to Max. Height
190968	SLC-1100	1,100	11-1/2"	35-3/4"	38-7/8"	33-1/2 x 19-3/4"	5"	27



**NEW**

## PARTS WASHERS

### 20 Gallon - Heavy Duty

- Lid hinge equipped with fusible link for added fire safety
- 45 litre working capacity tank includes basket and work shelf
- Flexible delivery spigot
- Screened inlet protects pump from foreign material
- Warnock Hersey approved
- For use with water-based cleaning solutions with a flash point of 60°C or higher

PROD. NO.	MOD. NO.	Motor	Tank Dimensions
<b>355002</b>	JPW-634	<b>115 Volt / 60 Hz. / 0.5 Amp</b>	30" W. x 21" D. x 36" H.

**NEW**

### 40 Gallon - Heavy Duty

- Lid hinge equipped with 2 x fusible links for added fire safety
- Extra large (70-83 litre) working capacity
- Comes with ground fault interrupt plug
- CUL approved
- For use with water-based cleaning solutions with a flash point of 60°C or higher

PROD. NO.	MOD. NO.	Motor	Tank Dimensions
<b>355003</b>	JPW-635	<b>115 Volt / 60 Hz. 0.5 Amp</b>	43-1/4" W. x 10-5/8" D. x 20-1/2" H.

### Flo-Thru Parts Brush

- Reduces parts cleaning time by 50%
- 4" long bristles suitable for use with water based (aqueous) cleaner, as well as petroleum based product
- Easy attachment fitting fits most parts washers



PROD. NO.	MOD. NO.	Product Dimension
<b>355091</b>	JPWB-6356	10" L. x 1-1/2" W.

## 37" Fixed Head 6 Wheel Creeper

- Creepers make repairs faster and easier
- Full length padded centre panel
- Six double post swivel casters for easy manoeuvrability and even distribution of weight to prevent creeper from bowing
- Creeper bed is only 3-1/2" high

PROD. NO.	MOD. NO.	Length x Width x Height	Clearance	Maximum Capacity	Wheel Size
<b>355105</b>	JFHC-640	37" x 18" x 3-1/2"	3-1/2"	300 lbs	2-1/2"



**NEW**

## 42" Adjustable Head Creeper

- Adjustable headrest reduces stress on neck muscles
- Drop shoulder for ease of movement
- Six double post casters for easy manoeuvrability and even distribution of weight to prevent creeper from bowing

PROD. NO.	MOD. NO.	Length x Width x Height	Clearance	Maximum Capacity	Wheel Size
<b>355115</b>	JAHC-643	42" x 15" x 3-1/2"	3-1/2"	300 lbs	2-1/2"



**NEW**

## 6 Wheel Mechanic's Creeper

- Unique closed cell construction provides unparalleled strength and rigidity
- Designed for unrestricted arm movement
- 6 large casters with ball bearings for easy manoeuvrability
- Dual parts trays
- Large padded head rest
- Can be hung out of the way using convenient handle
- Made of high quality chemical resistant HDPE for long life
- Easily recyclable where facilities exist
- Available in 4 PC POP display



**NEW**

PROD. NO.	MOD. NO.	Length x Width x Height	Clearance	Maximum Capacity	Wheel Size
<b>355130</b>	JBMC-620	39-1/2" x 18-1/2" x 4-5/16"	7/8"	400 lbs	3"



**NEW**

**NEW**

## ROLLER SEATS

### Mechanic's Roller Seat

- Padded seat rolls on ball bearing casters
- Reinforced vinyl over 1-3/4" thick foam
- Convenient under seat tray keeps tools and parts in easy reaching distance
- Frame is constructed of 1" steel tubing

PROD. NO.	MOD. NO.	Width x Depth x Height	Casters (4)
<b>355153</b>	JMS-641	<b>14" x 17-1/2" x 14-1/4"</b>	2-1/2"

### Mechanic's Adjustable Height Roller Seat

- Air piston allows for height adjustment
- Padded seat rolls on ball bearing casters
- Convenient under seat tray keeps tools and parts in easy reaching distance

PROD. NO.	MOD. NO.	Height	Maximum Capacity	Casters (5)
<b>355158</b>	JMS-642	<b>18"</b>	<b>300 lb (135 kg)</b>	2-1/2"



## Anti-Fatigue Mats

- Thick closed cell EVA foam pads protect workers from hard, rough surfaces
- Resists absorption of water, oil and many chemicals, is non-conductive and easy to clean
- Ultra-light weight for portability, with convenient hand hole for easy carrying and storage
- Can be used as an anti-fatigue mat, kneeling pad, under car mat, or anywhere a worker needs to be kept off the ground
- Ideal for service vehicles, roofers, installers, mechanics, shippers, production line workers, store clerks etc.
- Due to the nature of this product no warranty is offered

**NEW**

PROD. NO.	MOD. NO.	Product Dimension (Width x Depth x Height)
355191	JAFM-500	19-1/4" x 11-3/4" x 1-3/16"
355193	JAFM-1100	43" x 19-5/8" x 1-3/16"







# **Metal / Woodworking Machinery**

BENCH GRINDERS  
DRILL PRESSES  
METAL BANDSAWS  
DUST COLLECTOR



2 YEAR WARRANTY

## BENCH GRINDERS

- Heavy duty construction for maximum service life
- CSA electrics for safety and reliability
- All ball bearing construction
- Steel wheel covers with rear dust exhaust ports
- Easy to adjust steel tool rests
- Eye shields and spark guards for operator safety
- Rubber feet on base for reduced vibration
- Includes coarse and medium grinding wheels

### Heavy Duty

PROD. NO. MOD. NO.	<b>240153</b> BGC-6	<b>240154</b> BGC-8
<b>Motor</b>	1/3HP, 1Ph, 115V	1/2HP, 1Ph, 115V
<b>Amperage</b>	3.5, 60Hz	5, 60Hz
<b>R.P.M.</b>	3,450	3,600
<b>Arbor Size</b>	1/2"	5/8"
<b>Wheel Size</b>	6" x 3/4" x 1/2"	8" x 1" x 5/8"
<b>Product Weight</b>	26 lbs	39 lbs
<b>Shipping Weight</b>	28 lbs	42 lbs

## OPTIONAL ACCESSORIES

### JET High Performance Wire Brushes

PROD. NO.	MOD. NO.	Dia.	Min Face Width	Centre Hole	Maximum RPM	Wire Dia. & Type
<b>550121</b>	101F-2M	6"	7/8"	1/2" - 5/8" - 2"	6,000	.014" <b>M</b>
<b>550123</b>	101F-2F	6"	7/8"	1/2" - 5/8" - 2"	6,000	.007" <b>F</b>
<b>550124</b>	101F-3C	6"	1"	1/2" - 5/8" - 2"	6,000	.020" <b>C</b>
<b>550125</b>	101F-3M	6"	1"	1/2" - 5/8" - 2"	6,000	.014" <b>M</b>
<b>550141</b>	101G-2C	8"	7/8"	1/2" - 5/8" - 2"	4,500	.020" <b>C</b>
<b>550142</b>	101G-2M	8"	7/8"	1/2" - 5/8" - 2"	4,500	.014" <b>M</b>
<b>550143</b>	101G-2F	8"	7/8"	1/2" - 5/8" - 2"	4,500	.007" <b>F</b>

**F** = Fine      **M** = Medium      **C** = Coarse

### General Purpose Grinding Wheels

PROD. NO.	MOD. NO.	Size	Grade	Maximum RPM
<b>522163</b>	A675C	6" x 3/4" x 1"	<b>36</b>	4,138
<b>522164</b>	A675M	6" x 3/4" x 1"	<b>46</b>	4,138
<b>522165</b>	A675F	6" x 3/4" x 1"	<b>60</b>	4,138
<b>522173</b>	A610C	6" x 1" x 1"	<b>36</b>	4,138
<b>522174</b>	A610M	6" x 1" x 1"	<b>46</b>	4,138
<b>522175</b>	A610F	6" x 1" x 1"	<b>60</b>	4,138
<b>522176</b>	A610EF	6" x 1" x 1"	<b>80</b>	4,138
<b>522263</b>	A875C	8" x 3/4" x 1"	<b>36</b>	3,600
<b>522264</b>	A875M	8" x 3/4" x 1"	<b>46</b>	3,600
<b>522265</b>	A875F	8" x 3/4" x 1"	<b>60</b>	3,600
<b>522273</b>	A810C	8" x 1" x 1"	<b>36</b>	3,600
<b>522274</b>	A810M	8" x 1" x 1"	<b>46</b>	3,600
<b>522275</b>	A810F	8" x 1" x 1"	<b>60</b>	3,600

80 Grade = **Extra Fine**    36 Grade = **Coarse**    46 Grade = **Medium**    60 Grade = **Fine**

550125

522263



## 13-1/2" 3/4 HP 12 Speed Drill Presses

- Powerful 3/4 horse power motor
- 12 speed capability allows for a broad assortment of drilling applications
- Safety on/off switch with removable lock-out key
- Fully hinged belt and pulley cover and fully adjustable motor mount permit fast changes of spindle speed
- Worktable with quick release clamp rotates and tilts to 45° right and left
- Slots in worktable and base permit easy clamping of the work piece
- Positive depth setting mechanism uses a threaded rod and two lock nuts for accuracy
- Built-in work lamp with separate switch (bulb not included)

**Standard Equipment:** Drill chuck and key



PROD. NO. MOD. NO.	<b>200225</b> JDP-13	<b>200275</b> JDP-13F
<b>Swing</b>	<b>13-1/4"</b>	<b>13-1/4"</b>
<b>Type</b>	Bench Top	Floor Model
<b>Chuck Size</b>	5/8"	5/8"
<b>Drilling Capacity</b>	5/8"	5/8"
<b>Spindle Travel</b>	3-1/8"	3-1/8"
<b>Spindle Distance to Base</b>	24"	48-3/4"
<b>Spindle Distance to Table (Maximum)</b>	17-1/2"	31-1/2"
<b>Table Size (Diameter)</b>	11-3/8"	11-3/8"
<b>Table Tilt (Right and Left)</b>	0° - 45°	0° - 45°
<b>Spindle Taper</b>	MT2	MT2
<b>Column Diameter</b>	2-7/8"	2-7/8"
<b>Number of Spindle Speeds</b>	12	12
<b>Range of Spindle Speeds</b>	280-3,000 RPM	280-3,000 RPM
<b>Overall Height</b>	38-1/2"	61-5/8"
<b>Base size</b>	10" x 16-1/2"	10" x 16-1/2"
<b>Motor</b>	3/4HP, 1PH, 115/230V 5.2/2.6 Amps, Pre-wired 115V	3/4HP, 1PH, 115/230V 5.2/2.6 Amps, Pre-wired 115V
<b>Product Weight</b>	94 lbs	107 lbs
<b>Shipping Weight</b>	99 lbs	112 lbs



200225



200275

## 17" 1 HP 16 Speed Drill Press

- Powerful 1 horse power motor
- Full 17" swing for easy drilling of larger work pieces
- 16 speed capability allows for a broad assortment of drilling applications
- Safety on/off switch with removable lock key
- Fully hinged belt and pulley cover and quick adjust motor mount permit fast changes of spindle speed
- Worktable with quick release clamp rotates and tilts to 45° right and left
- Slots in worktable and base permit easy clamping of the work piece
- Positive depth setting mechanism uses a threaded rod and two lock nuts for accuracy
- Built-in work lamp with separate switch (bulb not included)

**Standard Equipment:** Drill chuck and key



**2** YEAR WARRANTY



PROD. NO.  
MOD. NO.

**200278**  
JDP-17F

<b>Swing</b>	<b>17"</b>
<b>Type</b>	Floor Model
<b>Chuck Size</b>	5/8"
<b>Drilling Capacity</b>	5/8"
<b>Spindle Travel</b>	3-1/4"
<b>Spindle Distance to Base</b>	48-3/8"
<b>Spindle Distance to Table (Maximum)</b>	28"
<b>Table Size (Diameter)</b>	13-3/4"
<b>Table Tilt (Right and Left)</b>	0° - 45°
<b>Spindle Taper</b>	MT2
<b>Column Diameter</b>	3-1/8"
<b>Number of Spindle Speeds</b>	16
<b>Range of Spindle Speeds</b>	220-3,380 RPM
<b>Overall Height</b>	64-1/2"
<b>Base size</b>	12" x 19-3/4"
<b>Motor</b>	1HP, 1Ph, 115/230V 8.5/4.25 Amps, Pre-wired 115V
<b>Product Weight</b>	176 lbs
<b>Shipping Weight</b>	184 lbs

## 22" 1-1/2 HP 12 Speed Drill Press

- Powerful 1-1/2 horse power motor
- Full 22" swing for easy drilling of larger work pieces
- 12 speed capability allows for a broad assortment of drilling applications
- Safety on/off switch with removable lock key
- Fully hinged belt and pulley cover and quick adjust motor mount permit fast changes of spindle speed
- Worktable with quick release clamp rotates and tilts to 45° right and left
- Slots in worktable and base permit easy clamping of the work piece
- Positive depth setting mechanism uses a threaded rod and two lock nuts for accuracy
- Built-in work lamp with separate switch (use outdoor rated bulb, not included)

**Standard Equipment:** Drill chuck and key



PROD. NO. MOD. NO.	<b>200357</b> JDP-22F
<b>Swing</b>	<b>22"</b>
<b>Type</b>	Floor Model
<b>Chuck Size</b>	3/4"
<b>Drilling Capacity</b>	1-1/4"
<b>Spindle Travel</b>	4-1/2"
<b>Spindle Distance to Base</b>	49"
<b>Spindle Distance to Table (Maximum)</b>	29"
<b>Table Size (Diameter)</b>	16-1/2" x 18-3/4"
<b>Table Tilt (Right and Left)</b>	0° - 45°
<b>Spindle Taper</b>	MT3
<b>Column Diameter</b>	3-5/8"
<b>Number of Spindle Speeds</b>	12
<b>Range of Spindle Speeds</b>	180-4,200 RPM
<b>Overall Height</b>	69-1/4"
<b>Base size</b>	19-5/8" x 22-1/2"
<b>Motor</b>	1.5HP, 1Ph, 115/230V 10.0/5.0 Amps. Pre-wired 115V
<b>Product Weight</b>	353 lbs
<b>Shipping Weight</b>	373 lbs





# METAL CUTTING BANDSAWS



## 4" x 6" 1/3 HP 3 Speed Belt Drive Bandsaw

- Sturdy cast iron saw frame and base
- 1/3 HP motor shuts off automatically when the workpiece is cut through
- Three speeds permit cutting of most materials including metal, plastic and wood
- Designed for horizontal and vertical cutting
- Vise permits mitre cuts to 45° and features a scale for accuracy
- Two wheels and handle permit easy movement
- Convenient shelf mounts under base

**Standard Equipment:** blade; stand; wheels; shelf; vertical work table; material stop; vise



**2 YEAR WARRANTY**

PROD. NO.  
MOD. NO.

**222326**  
JHVB-46

<b>Capacity 90°</b>	4-1/2" ● 4" x 6" ■
<b>Blade Size</b>	1/2" x 0.025" x 64-1/2"
<b>Vertical Work Table</b>	7" x 8"
<b>Vise Tilts</b>	45°
<b>Blade Speeds (SFPM)</b>	80, 120, 220
<b>Motor</b>	1/3 HP, 1Ph, 115 Volt, 1,725 RPM
<b>Shipping Dimensions</b>	40-1/2" x 12-3/4" x 15-3/4"
<b>Net Weight (approx.)</b>	134 lbs
<b>Shipping Weight (approx.)</b>	140 lbs

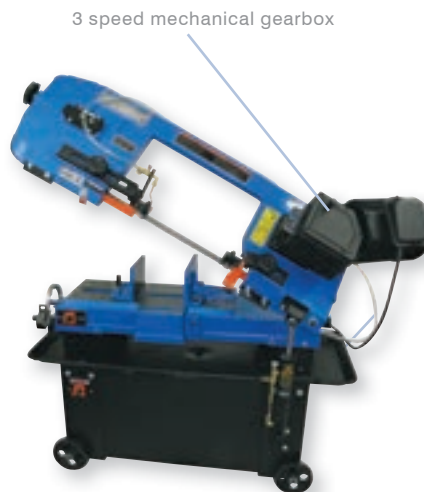

## 7" x 12" 1 HP 3 Speed Gearbox Bandsaw

- Heavy duty cast iron construction for accuracy and durability
- Three speed gear box replaces less efficient belt drive systems found on most comparable machines
- Horizontal cutting feed rate controlled by a fully adjustable hydraulic ram
- Coolant delivery system provides fast cutting while extending the service life of the blade and the saw
- Quiet cutting, rated within 70 decibels
- Easy cleaning with removable filter screen
- Automatic shut-off system stops the machine when the stock is cut through
- Quick action vise adjusts from 90° to 45° for mitre cutting
- Cuts up to 7" round stock and up to 7" by 12" rectangular stock
- Full 1HP, single phase motor
- Complete with four wheels for mobility

**Standard Equipment:** blade; coolant system; material stop system; 4 wheels; vertical work table; enclosed stand; blade chip brush; quick action vise



**2 YEAR WARRANTY**

PROD. NO.  
MOD. NO.

**222332**  
JHVG-712

<b>Capacity 90°</b>	7" ● 7" x 12" ■
<b>Capacity 45°</b>	4" ● 5" x 6" ■
<b>Throat Depth</b>	7"
<b>Blade Size</b>	3/4" x 0.032" x 93"
<b>Vertical Work Table</b>	9-1/2" x 10"
<b>Vise Tilts</b>	45°
<b>Blade Speeds (SFPM)</b>	125, 215, 270
<b>Floor Space Required</b>	49-1/2" x 17-1/2"
<b>Motor</b>	1 HP, 1Ph, 115/230 Volt Pre-wired 115V; 1,720 RPM
<b>Shipping Dimensions</b>	51" x 18" x 40"
<b>Net Weight (approx.)</b>	318 lbs
<b>Shipping Weight (approx.)</b>	345 lbs





## 9" x 16" 1-1/2 HP 4 Speed Belt Drive Bandsaw

- Designed for industrial use, this saw features a heavy duty steel and cast iron saw frame
- One piece cast iron saw bed
- Enclosed base, welded for strength
- Precision cast 13" blade wheels
- Coolant system includes: pump and reservoir; fully adjustable delivery nozzles at front and rear blade guides; coolant pick-up port in the drive wheel housing; quick-check gauge for coolant level
- Removable chip tray for easy cleaning
- Totally enclosed 1-1/2 HP fan cooled motor with 24 volt controls
- Four speed belt drive system
- Hydraulically controlled feed rate with micro adjust switch
- Automatic shut-off limit switch
- Blade guide system consists of ball bearing thrust roller, ball bearing blade guides and tungsten carbide slides
- Moveable left blade guide arm adjusts from 16" to 7" capacity
- Quick set vise adjusts for 90° to 45° angle cuts
- Material stop with 24" capacity
- Each machine factory tested and set

**Standard Equipment:** variable pitch blade; blade chip brush; coolant system; tool kit; quick set vise and material stop



**2** YEAR WARRANTY

PROD. NO.  
MOD. NO.

**222335**  
JHBS-916

<b>Capacity 90°</b>	9" ● 4" x 16" - 9" X 12" ■
<b>Capacity 45°</b>	6-1/2" ● 9" X 6-1/8" ■
<b>Throat Depth</b>	9"
<b>Blade Size</b>	1" x 0.032 x 119-1/2"
<b>Blade Speeds (SFPM)</b>	82, 132, 170, 235
<b>Bed Height</b>	25"
<b>Floor Space Required</b>	65" x 28"
<b>Motor (TEFC)</b>	1-1/2HP, 1PH, 230V complete with 24V control panel
<b>Vise Swivels</b>	45°
<b>Wheel Diameter</b>	13"
<b>Net Weight (approx.)</b>	627 lbs
<b>Shipping Weight</b>	704 lbs



## DUST COLLECTOR

### High Air Flow Woodworking

- Industrial quality motor and construction to effectively handle the collection of wood chips and sawdust
- Single-stage design allows economical, quiet operation and easy cleaning
- Four casters stabilize unit and allow total mobility
- Industrial controls are designed for years of trouble-free operation
- Powerful, single phase motor is permanently lubricated, totally enclosed, fan-cooled and is continuous-duty rated
- Features welded and sealed joints throughout
- Improved metal impellers are precision balanced and run on long lasting bearings extending tool life
- Super high air flow volumes keep your air cleaner and safer than competing brands
- Higher static pressure rating and velocity capacity
- Bigger bags offer more capacity and better filtration. Top bag is rated at 20 microns, bottom bag is rated at 30 microns, offering optimum air flow efficiency; bottom bags offer see-through window
- Long lasting steel straps ensure secure bags

**Standard Equipment:** 20 micron filter bag; 30 micron collector bag; wheel casters; steel straps to secure bags; connecting hose not included.  
– JDC-830: Single (4") hose connection

**Optional Accessories:** **912805** FB830 Filter Bag;  
**912807** CB830 Collector Bag

PROD. NO.  
MOD. NO.

**252926**  
JDC-830

Blower Wheel (Diameter)	10"
Sound Rating @ 3ft. (dB)	60-70
Diameter of Hose Connections	1 Hose 4"
Bag Diameter	14-1/2"
Bag Length	24-1/4"
Filter Bag (top bag)	20 micron
Collector Bag (bottom bag)	30 micron
Collector Bag Capacity complete with see-through panel:	20 USG
Air Flow @ 4	830
Static Pressure (Inch of Water)	7.2
Velocity @ 4	9,446
Overall Dimensions (L x W x H)	31-1/2" x 16-1/2" x 61"
4 Casters	Yes
Motor continuous duty rated (TEFC)	1HP, 1Ph, 115/230V Pre-wired 115V





# Pullers

GEAR PULLERS

BEARING SEPARATOR

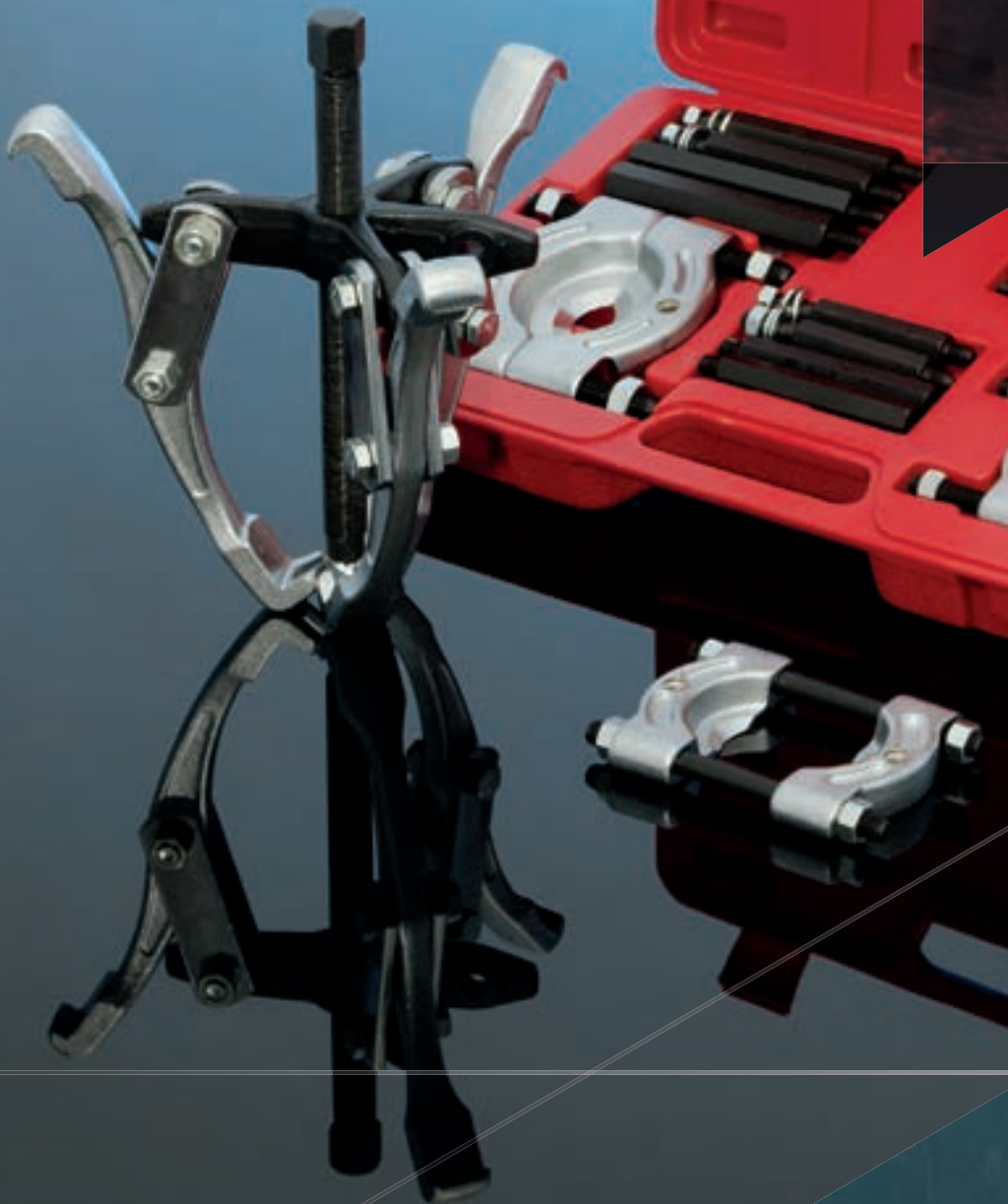



# GEAR PULLERS - HEAVY DUTY

Made of the highest quality drop forged Chrome Vanadium steel for professional use



770134



770135

## 2 or 3 Jaw Combination Gear Pullers

- Assemble with 3 jaws for maximum stability, or with 2 jaws where access is limited – 2 pullers in 1
- Jaws, yokes and forcing screw made of heat treated Chrome Vanadium steel for ultimate strength
- Reversible jaw design allows internal and external pulling
- Jaws grip tighter as pulling force increases
- All components hardened to HRC 42~45 for professional use
- Fine-threaded 440 CrV forcing screw allows precise control for damage free pulling
- Can be used with bearing separators

PROD. NO.	MOD. NO.	Reach	Spread	Capacity	Screw Length	Pitch	Jaw Thickness	Jaw Width
770132	JGP-3HD	3-1/4"	4-3/4"	2 tons	4.9"	3/8"-24 tpi	1/8, 1/4"	1/4, 7/16"
770133	JGP-4HD	3-1/2"	7"	5 tons	7"	9/16"-20 tpi	3/8, 3/4"	1/4, 5/16"
770134	JGP-6HD	5-1/2"	7"	5 tons	7"	9/16"-20 tpi	1/4, 5/16"	3/8, 3/4"
770135	JGP-8HD	5-1/2"	9-1/2"	5 tons	9"	11/16"-18 tpi	5/16, 11/32"	7/8"



## Hydraulic Gear Puller Set

- Jaws, yokes, bearing separator and ram made of heat treated Chrome Vanadium steel for ultimate strength
- Hydraulic ram requires no power - develops up to **10 tons of pressure** with hand power only
- All components hardened to HRC 42~45 for professional use
- Includes twin and triple heads for assembling 2 jaw and 3 jaw pullers
- Includes 4-1/2" bearing separator
- Comes in a convenient blow mould storage case

PROD. NO.	MOD. NO.	Reach	Spread	Capacity	Pieces (total)
<b>770152</b>	JHGP-10S	<b>4"</b>	<b>10"</b>	10 tons	22

**Contents:** Hydraulic Ram (1), 4" Puller Legs (3), 6" Puller Legs (3), 8" Puller Legs (3), Collar (1), Twin Head (1) Triple Head (1), End Cap (1), 2" Ram Extension (1), Yoke (1), 4-1/2" Bearing Separator (1), Main Rods (2), Extension Rods (2)



770152

## BEARING SEPARATORS - HEAVY DUTY

- Separator bodies made of heat treated Chrome Vanadium steel for maximum strength
- All components hardened to HRC 42~45 for professional use
- Separators have knife like edges to get behind bearings where regular gear puller jaws are too thick to grip
- Can be used with push or pull type gear pullers

### 12 Piece Set

**770302 / JBS-12**

Maximum Reach	Capacity	Forcing Screw	Hole Size
3"	5 tons	7", 9/16" x 10 tpi	3/8" x 16 tpi

**Contents:** 2-1/4" Bearing Separator (1), 3-1/2" Bearing Separator (1), Yoke (1), Forcing Screw (1), Main Rods (4), Extension Rods (4)



770302



### Open Stock

PROD. NO.	MOD. NO.	Capacity	Hole Size
<b>770312</b>	JBS-225	<b>1-3/16" - 2-1/4"</b>	3/8" x 16 tpi
<b>770313</b>	JBS-350	<b>2-1/4" - 3-1/2"</b>	3/8" x 16 tpi
<b>770314</b>	JBS-450	<b>3" - 4-1/2"</b>	1/2" x 16 tpi

**GEAR PULLERS**  
See page 280 in the Specialty Auto section for similar products

# SPECIALTY PULLERS

JET carries a complete line of Speciality Automotive pullers for every need. Below is a summary of these pullers  
 Please refer to pages 282 of this catalogue for details



H3341



H1921



H1901



H1903



H1905



H3560



H3565



H3566



H3562



## **Lubrication/ Fluid Transfer**

GREASE GUNS  
GREASE GUN ACCESSORIES  
GREASE FITTINGS  
GREASE PUMPS  
GREASE PUMP  
ACCESSORIES  
WATER, CHEMICAL AND  
OIL PUMPS  
OIL AND FUEL PUMPS  
FUEL AND GASOLINE PUMPS  
OIL DRAINS  
DRUM HANDLING



## GREASE GUNS



### Lever Action

350151 / JLGG-14S

- Uses standard **14 oz. grease cartridge** or can be bulk filled
- Rugged electro-static epoxy coated finish resists corrosion
- Deep knurling for non-slip grip
- Heavy duty steel barrel for long life
- Machined steel head protects hardened steel plunger
- V-handle posi-lock follower rod for sure grip and easy filling in any position
- Ideal for home, farm, maintenance and shop use
- Complete with 6" rigid pipe extension and coupler
- Delivers 1 gm / stroke or 1 oz. / 28 strokes
- Produces up to 6,000 PSI



Die cast head

Comes with rigid extension

### Lever Action – Heavy Duty

350152 / JLGG-14HD

- A premium, heavy duty grease gun built tough for the professional, industrial markets
- Added filler nipple allows three way loading; bulk, filler pump or standard **14 oz. cartridge**
- Air bleeder valve easily purges unwanted air
- Variable stroke for working in confined areas
- Rugged electro-static epoxy coated finish resists corrosion
- Deep knurling for non-slip grip
- Heavy duty steel barrel for long life
- Die cast head protects hardened steel plunger
- T-handle posi-lock follower rod for sure grip and easy filling in any position
- Comfortable sure grip rubber handle makes pumping easy and convenient
- **Complete with 6" rigid extension and heavy duty coupler**
- A must for heavy maintenance, industrial, automotive and farm use
- Delivers 1 gm / stroke or 1oz. / 28 strokes
- Produces up to 10,000 PSI



Die cast head

Comes with rigid and flex extension

### Pistol Grip – Heavy Duty

350155 / JPGG-14HD

- Pistol grip design offers convenient one-handed operation
- Die cast head protects hardened steel plunger
- Uses standard **14 oz. grease cartridge** or can be bulk filled
- Rugged electro-static epoxy coated finish resists corrosion
- Deep knurling for non-slip grip
- T-handle posi-lock follower rod for sure grip and easy filling in any position
- **Includes 4" rigid pipe extension, 18" flexible hose and heavy duty coupler**
- Delivers 0.50 gm / stroke or 0.70 oz. / 40 strokes
- Produces up to 5,000 PSI



## High Pressure / High Volume - Heavy Duty 350156 / JPGG-14HPHV

- Convenient lever mounted switch converts gun for high pressure or high volume use while maintaining one-hand operation
- Threadless barrel with quick connect lever allows for super-fast reloading with no danger of crossing threads
- Uses standard **14 oz. grease cartridge** or can be bulk filled
- Complete with air bleeder and bulk loader valves
- Deep knurling for non-slip grip
- T-handle posi-lock follower rod for sure grip and easy filling in any position
- **Includes 12" Heavy Duty flexible hose and coupler**
- Delivers 0.90 gm / stroke or 1 oz. / 31 strokes
- Produces up to 7,000 PSI

**NEW**



## Single Shot Air Powered – Heavy Duty 350161 / JAGG-14P

- A premium heavy duty air powered grease gun for the most demanding professional user
- Intermittent action delivers one shot of grease for every pull of the trigger
- Added filler nipple allows 3 way loading; bulk, filler pump, or standard **14 oz. cartridge**
- Heavy duty die cast aluminum head
- Precision honed barrel for fast action
- Air pressure 40 – 120 PSI at 1 cfm or greater
- T-handle posi-lock follower rod for sure grip and easy filling in any position
- Complete with male quick coupler air fitting
- Delivers 0.90 gm / shot or 1.30 oz. / 40 shots
- Produces up to 4,800 PSI
- **Includes 6" rigid extension, 12" flexible hose and heavy duty coupler**

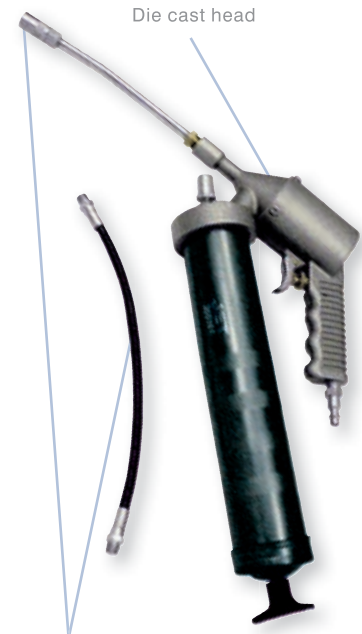

Comes with rigid and flex extension

## Continuous Flow Air Powered – Heavy Duty

350162 / CFAGG-14HD

- Automatic continuous flow of grease while trigger is depressed
- 40:1 Pump Ratio
- Minimum inlet air pressure 40 PSI to Maximum 120 PSI (2.7 to 10.3 bar)
- Develops up to 4,800 PSI pressure
- Added filler nipple allows 3 way loading; bulk, filler pump, or standard **14 oz. cartridge**
- Air vent valve included for releasing air pockets
- Output per stroke 14 oz. per minute
- Lubricant up to NLGI #2 Grease
- Air Inlet 1/4-18 NPT
- Grease Outlet 1/8-27 UNPT
- **Includes 6" rigid extension, 12" flexible hose and heavy duty coupler**

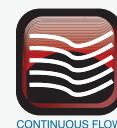



## GREASE GUNS



Pre-loaded with NLGI Grade 2 grease

### Pistol Grip - Mini Style - Heavy Duty

350171 / JMPG-16

- Convenient pull type trigger for easy one hand operation
- Die cast head
- Textured zinc plated finish for non slip grip
- Uses standard **3 oz. grease cartridges** or can be bulk filled (grease not included)
- T-handle posi-lock follower rod for sure grip
- Complete with **4" rigid pipe extension and professional coupler**
- Produces up to 3,500 PSI
- Delivers 0.40 gm / stroke or 0.60 oz. / 40 strokes

### Push Type - Mini Tool Box Style

350173 / JPTG-1

- Perfect tool box companion for lubrication of tools on the job
- Universal connector fits all standard fittings
- Comes pre loaded with NLGI grade 2 grease
- Can be re-filled
- Transparent barrel provides clear view of remaining grease
- Sealed design to prevent leakage
- Pre-loaded with NLGI Grade 2 grease

## GREASE GUN HOSES

- Replacement whip hoses
- Polyamide inner tube with polyurethane outer tube, reinforced with highly tear resistant polyester

### High Pressure - Regular Style

- Heavy duty high pressure (11,600 PSI burst pressure)
- Working pressure 3,500 PSI

PROD. NO.	MOD. NO.	Length	Type	Thread
350181	JFH-12	12"	Flexible	1/8" NPT
350182	JFH-18	18"	Flexible	1/8" NPT

### High Pressure - Spring Style

- Fitted with heavy duty spring for added safety, strength and life
- Heavy duty high pressure (11,600 PSI burst pressure)
- Working pressure 3,500 PSI

PROD. NO.	MOD. NO.	Length	Type	Thread
350201	JFH-12SP	12"	Flexible	1/8" NPT
350202	JFH-18SP	18"	Flexible	1/8" NPT



Regular



Spring Style



Super Heavy Duty

### High Pressure - Super Heavy Duty

**NEW**

- Two layer construction consisting of a polyamide inner tube with a tough polyurethane sheath, reinforced diagonally with highly tear resistant polyester
- Extra large inner diameter is ideal for cold weather use
- Spring guard adds strength and safety
- For hand and air operated grease guns and control valves
- Working pressure 5,800 PSI • Burst pressure 13,775 PSI

PROD. NO.	MOD. NO.	Length	Type	Thread
350215	JFH-12HP	12"	Flexible	1/8" NPT
350216	JFH-18HP	18"	Flexible	1/8" NPT



## Quick Change Coupler Adaptors



### 7 PC Quick Change Coupler Set

350213 / JQCC-7S

- Quick change feature snaps directly onto jaw type couplers – no need to remove hydraulic coupler to change accessories
- Instantly converts jaw type couplers for fine line greasing for access to confined areas
- Protective sleeve secures connection
- Ideal for applications where fittings are in hard-to-reach areas
- For hand operated grease guns
- **Set contains one of each below (except 350205):**



### Recessed Lube Adaptor

350208 / JRLA-1

- 4" length, tip diameter 0.22"
- For push on greasing of fittings where obstruction will not allow use of regular coupler



### Right Angle Coupler

350211 / JRAC-2

- Working pressure 1,000 PSI
- Particularly useful in low height applications
- Polyurethane seal fits perfectly on grease fitting



### Needle Nose Adaptor

350210 / JNND-2

- 1-1/2" needle length, diameter 0.156"



### Grease Injector Needle

350206 / JGIN-15

- Lubricates in extremely tight places including U-joints and sealed bearings
- Fits directly on jaw type couplers
- 18 gauge stainless steel
- 1-1/2" long
- With protective plastic cover



### Seal-Off Dispenser

350212 / JSOD-1

- Used for lubricating cars with grease plugs
- Oil and grease resistant rubber tip



### 90° Angle Lube Adaptor

350209 / JALA-1

- .019" diameter



### Needle Nose Dispenser

350205 / JNND-1

- For dispensing fine line of grease
- Allows contact with flush or hard-to-reach fittings in inaccessible areas
- 1-1/2" needle length, diameter 0.156"
- 1/8" NPT threads





## GREASE GUN ACCESSORIES

### Grease Gun Couplers

- For hand operated grease guns
- Professional industrial quality

### 4 Jaw - Heavy Duty

350203 / JPDC-4

- Hardened body withstands high pressure without deformation
- Working pressure 6,000 PSI
- 1/8" NPT threads



### Right Angle - Heavy Duty

350204 / JRAC-1

- Unique design for greasing fittings in hard to reach areas
- Particularly useful in low height applications
- Polyurethane seal fits perfectly on grease fitting
- Working pressure 1,000 PSI
- 1/8" NPT threads



350218

350217

NEW

Button Head – Heavy Duty

- Specifically designed to fit 5/8" and 7/8" button head fittings found on heavy machinery
- Metal seal resists wear

PROD. NO.	MOD. NO.	Threads	Working Pressure
350217	JBHC-58	1/8" NPT	6,000 PSI
350218	JBHC-78	1/8" NPT	7,500 PSI

### Swivel Type - Heavy Duty

350207 / JSGC-360

- Built in 360° swivel locks in eight positions
- Working pressure 7,000 PSI
- 1/8" NPT threads
- Fully hardened 3 jaw construction



## GREASE GUN HOLDERS

### Grease Gun Holder 350185 / JGGH-1

- Conveniently mounts any 2-1/4" O.D. grease gun to almost any surface



### Grease Gun Holder - Heavy Duty

350189 / JGGH-2HD

- Designed specifically for mounting on construction equipment, farm vehicles, tractor trailers and other vehicles subject to high vibration
- Heavy duty spring retains gun securely and allows easy removal and replacement
- Four mounting bolts for secure attachment
- Fits 2-1/4" and 2-1/2" barrel diameters



**NEW**

**101 PC S.A.E. Grease Fitting and Tool Set – Heavy Duty 350263 / JGFK-101**

- Contains 99 S.A.E. Grease Fittings and 2 multi-purpose fitting tools
- CONTENTS:**
- 1/8"-27 NPT: 22 Straight, 5 x 30°, 10 x 45°, 10 x 65°, 10 x 90°
  - 1/4"-28 S.A.E.-LT: 22 Straight, 10 x 45°, 10 x 90°
  - **350261** (JGFT-14) and **350262** (JGFT-18) fitting tools



350263

**NEW**

**40 PC S.A.E. Stainless Steel Grease Fitting Set - Heavy Duty 350264 / JGFK-40SS**

- Stainless steel fittings for use in marine and other corrosive environments
- CONTENTS:**
- 1/8"-27 NPT: 10 straight, 5 x 45°, 5 x 90°
  - 1/4"-28 SAE-LT: 10 straight, 5 x 45°, 5 x 90°



350264

**Sets - Heavy Duty**

PROD. NO.	MOD. NO.	Type	Pieces	Contents
<b>350257</b>	JGF-8S	S.A.E.	8	2 each: 1/4" - 28 Straight, 1/8" - 27 Straight, 1/8" - 27 45°, 1/8" - 27 90°
<b>350258</b>	JGF-8M	Metric	8	2 each: M6 x 1 Straight, M6 x 1 45°, M6 x 90°, M8 x 1
<b>350259</b>	JGF-80S	S.A.E.	80	15 x 1/4" - 28 Straight, 10 x 1/4" - 28 45°, 10 x 1/4" - 28 90°, 25 x 1/8" - 27 Straight, 10 x 1/8" - 27 45°, 10 x 1/8" - 27 90°
<b>350260</b>	JGF-80M	Metric	80	20 x M6 x 1 Straight, 10 x M6 x 1 90°, 15 x M8 x 1 Straight, 10 x M8 x 1 90°, 15 x M10 x 1 Straight, 10 x M10 x 1 90°



350259 / 350260



350257 / 350258



## GREASE FITTINGS



STRAIGHT  
350251 / 350254



45°  
350252 / 350255



90°  
350253 / 350256

### 10 Packs - Heavy Duty

PROD. NO.	MOD. NO.	Type	Pieces	Thread	Hex Size
<b>350251</b>	JGF-142800	Straight Fittings	10	1/4" – 28 S.A.E.	5/16"
<b>350252</b>	JGF-142845	45° Fittings	10	1/4" – 28 S.A.E.	3/8"
<b>350253</b>	JGF-142890	90° Fittings	10	1/4" – 28 S.A.E.	3/8"
<b>350254</b>	JGF-182700	Straight Fittings	10	1/8" – 27 NPT	7/16"
<b>350255</b>	JGF-182745	45° Fittings	10	1/8" – 27 NPT	7/16"
<b>350256</b>	JGF-182790	90° Fittings	10	1/8" – 27 NPT	7/16"

**NEW**



### Grease Fitting Unblocker

**350265 / JFUT-100**

- Opens clogged grease fittings and loosens hardened grease joints
- Tapping tool with a hammer forces a light viscosity oil into the fitting, breaking up and removing dirt and debris
- Excellent for maintaining bearings, control arms, king pins etc.
- Built-in hand guard for operator protection
- Complete with coupler and flex hose for reaching recessed fittings
- Includes 2 spare piston seals

### 4 Way Fitting Tools

- Handy multi-purpose fitting tools
- Wrench, tap and extractor in one
- Removes worn and broken fittings, re-taps threaded holes, installs new fittings
- Works with straight and angled fittings



350262



350261

PROD. NO.	MOD. NO.	Application
<b>350261</b>	JGFT-14	<ul style="list-style-type: none"> <li>• Tap repairs 1/4"-28 S.A.E. threaded holes</li> <li>• Wrench removes and installs 5/16" and 3/8" hex fittings</li> </ul>
<b>350262</b>	JGFT-18	<ul style="list-style-type: none"> <li>• Tap repairs 1/8"-27 NPT threaded holes</li> <li>• Wrench removes and installs 7/16" and 3/8" hex fittings</li> </ul>

## Grease Gun Filler Pump

350158 / JGFP-03

- Zinc die cast head and adjusting flange
- 18" zinc plated pump body
- Epoxy coated, corrosion resistant 12" drum cover
- All steel foot valve
- **Fits 25 - 50 lb / 5 gallon pails**
- Designed to load bulk or combination grease guns
- Delivers 28 gms on 1 oz. / stroke
- Suitable for use with light and medium density grease



## JET Heavy Duty 50:1 Grease Pumps

- Designed for everyday use in shops, factories and maintenance departments for quick and efficient dispensing of grease
- All units dispense 27 ounces per minute. Simply connect to your air system, pull the trigger and let these powerful pumps do the work
- Each unit comes with 18" whip hose/coupler, control valve, 4 meters of hose, drum cover and follower plate

### 50 lb Air Operated Grease Pump Kit - Heavy Duty

350306 / JAGP-25

- 50:1 Air Operated Grease Pump (25-50 lb container)
- Requires 70-115 PSI operating pressure
- Pumps up to 1.76 lbs per minute (27 ounces)
- 82 dB noise level
- 13' delivery hose
- 12-13/64" drum cover
- 10-3/8" follower plate
- Control valve
- Shipping Weight: 23 lb (10kg)



**NEW**

### 120 lb Air Operated Grease Pump Kit - Heavy Duty

350307 / JAGP-120

- 50:1 Air Operated Grease Pump (120 lb container)
- Requires 70-115 PSI operating pressure
- Pumps up to 1.76 lbs per minute (27 ounces)
- Comes with 4 wheel roll around cart
- 82 dB noise level
- 13' delivery hose
- 15" drum cover
- 14-1/2" follower plate
- Control valve
- Shipping Weight: 38 lbs (17 kg)



**NEW**



**NEW**



**NEW**



## GREASE PUMP ACCESSORIES

### Control Valve

**350311 / JAPG-CV**

- Premium quality, top of the line grease control valve for use with air operated equipment
- Provides continuous grease flow with trigger fully depressed
- Inlet thread: 1/4" NPT (F), Outlet thread: 1/8" NPT (F)

### Booster Grease Control Valve

**350312 / BGCV-1**

- Heavy duty grease control valve with built-in pressure boost mechanism
- Repeated actuation of handle boosts line pressure from 6,000 PSI up to 10,000 PSI
- Provides continuous flow with handle fully depressed
- Extremely useful for unblocking clogged fittings
- Complete with 6" rigid extension and 4 jaw heavy duty coupler
- Inlet thread 1/4" NPTF, outlet thread 1/8" NPT

### 360° Swivel

**350391 / JAGP-SW**

- 1/4"(M) x 1/2"-27(M)
- Installed between the delivery hose and grease control valve allowing greater mobility and control of the grease control valve
- Heavy duty steel construction with ball bearings for smooth operation and unrestricted movement
- Swivel joints are hardened for durability and greater wear resistance
- Maximum working pressure – 6,000 PSI



**NEW**

## Polyethylene Siphon Pumps

- Easy to use pumps siphon liquids to lower levels automatically once started
- 6 to 7 strokes of the bellows primes pump requiring no further operation
- Vent cap stops siphoning when opened
- Bellows can be continuously operated to pump liquids to higher levels than pump is installed
- Complete with flexible discharge hose
- **Recommended use:** water-based fluids, detergents, waxes, soaps, antifreeze, mild acid solutions, and other lightweight non-flammable liquids
- **Do not use with:** concentrated acids, acetone, benzene, fuels, fluids incompatible with wetted components, or liquids above 60°C (140°F)

PROD. NO.	MOD. NO.	Discharge	Bung Size	Fits	Wetted Components	Discharge Hose Length
350110	JPSP-2	2 GPM (6.5 LPM)	1-1/2"	5 gal / 5-20 L pails	Polyethylene	21-1/2"
350111	JPSP-5	5 GPM (17.5 LPM)	2"	55 gal / 205 L drums	Polyethylene and Polypropylene	46-1/2"
350112	JPSP-7	7 GPM (21 LPM)	2"	55 gal / 205 L drums	Polyethylene and PVC	47-3/4"

350110

350111

350112



## Chemical Pump - Nylon Body

350109 / JNCP-14

- Self-priming vertical lift pump
- **Fits 15 – 55 gallon drums**
- Delivers 14 oz. per stroke
- **Recommended use:** lacquer thinners, acetone, MEK, antifreeze, detergents, windshield washer fluids, mild acids, weed killer, water and glycerine
- **Do not use with:** strong acids or gasoline
- Wetted components: nylon, polypropylene, stainless steel and PTPE

## Chemical Pump - Polypropylene Body

350108 / JPCP-14

- Self-priming vertical lift pump
- **Fits 15 – 55 gallon drums**
- Delivers 14 oz. per stroke
- **Recommended use:** antifreeze, detergents, windshield washer fluid, mild acids and glycerine
- **Do not use with:** water, strong acids, lacquers, acetone and gasoline
- Wetted components: polypropylene, steel, Viton®



350109

350108



**NEW**

### Oil Cans

- Industrial quality
- Brass pump
- Electro-static, corrosion resistant epoxy coating
- Complete with flex hose and rigid spout

350125



## WATER, CHEMICAL & OIL PUMPS

### Plastic Lever Pump

350113 / JPLP-100

- Lever action barrel pump designed for use with high viscosity fluids
- Special design makes pumping thick liquids easier reducing operator fatigue
- Built in 2" bung adapter with lock nut allows pump handle to be positioned conveniently
- Air vent cap stops siphon action
- Delivers 500 ml per stroke
- **For use on 15 – 55 gallon (50 – 205 litre) drums**
- Complete with 6' corrugated discharge hose
- **Recommended use:** water-based fluids, detergents, waxes, soaps, antifreeze, windshield washer fluid, hydraulic oils, lubricants, pesticides and herbicides, Adblue®, Urea, DEF and other non-flammable liquids
- **Do not use with:** concentrated acids, acetone, benzene, fuels, thinners, solvents or fluids incompatible with wetted components
- Wetted components: polyacetal, polypropylene, polyethylene, PVC, Viton®

## OIL AND FUEL PUMPS

### Brass Pump Oil Cans

PROD. NO.	MOD. NO.	Capacity
350121	JOC-180	6 oz. / 180 ml
350122	JOC-300	10 oz. / 300 ml
350124	JOC-500	16 oz. / 500 ml
350125	JOC-700	24 oz. / 700 ml

All models complete with both flex and rigid spouts



# OIL AND FUEL PUMPS



## Barrel Pump - Lever Action - Heavy Duty 350105 / JLBP-01

- Suitable for use with all oil based fluids
- Fits 15 – 55 gallon drums
- Rugged epoxy coated pump assembly
- Tough all steel foot valve and piston valve
- Delivers 300 ml or 10 oz. / stroke
- Complete with 2 piece draw tube



## Bucket Pump - Lever Action - Heavy Duty 350106 / JLBP-02

- Suitable for transfer of transmission, differential and heavier oils
- Delivers 16 oz. / stroke
- Zinc die cast head and adjustable flange
- Fits 25 - 50 lb / 5 gallon pails
- Epoxy coated, corrosion resistant 12" drum cover
- 18" zinc plated pump body
- Complete with 48" fuel resistant soft PVC hose with nozzle



## Suction Gun 350157 / JSGG-18

- Rugged 18 oz. capacity suction gun for draining and filling differentials, clutches and transmissions
- Does not require priming
- Heavy duty steel barrel for long life
- Electro-static epoxy coated finish resists corrosion
- Deep knurling for non-slip grip
- T-handle posi-lock follower rod for sure grip
- Complete with flexible vinyl hose
- For use with any non-corrosive lubricants



## Brass Transfer Pump 350159 / JBTB-100

- Portable hand pump for quick and easy transferring or evacuating of a wide variety of media
- Non-corroding premium brass construction
- Self-priming
- Complete with 24" of 1/2" discharge hose and 40" of 1/4" suction hose
- Can be used to drain oil or transmission fluids through the dipstick hole – ideal for boats
- Transfer fluids from one container to another without lifting either
- Pumps 3.2 oz. (100ml) per stroke
- Wetted components: brass, neoprene



**NEW**



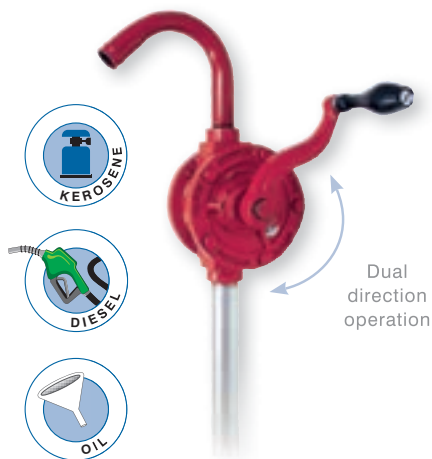

## OIL AND FUEL PUMPS

### Barrel Pump - Rotary - Heavy Duty

350103 / HRP-25

- Sturdy cast iron body with precisely machined cast iron vanes for better draw and smoother delivery
- Hi-Nitrile rubber pump seals
- Delivers 5 litres or 1.30 gallons per 20 revolutions
- Dual directional operation – pumps in either direction
- **Recommended use:** diesel, kerosene, heating oils, motor oils, lubrication oils (up to SAE 90) and other non-corrosive media
- **Do not use with:** gasoline, antifreeze, solvents, acids or water based media
- Comes with suction tube, 2" cast iron bung nut and steel discharge spout

### Plastic Rotary Pump

350114 / JPRP-200

- Rotary barrel pump designed for use with media which cannot be pumped with cast iron or steel pumps
- Glass filled polypropylene body with Ryton® vanes, Viton® seals and stainless steel hardware for maximum resistance to chemicals
- Strainer fitted on suction tube prevents contaminants from entering pump
- Delivers 1 litre per 4 turns
- Includes 2" threaded bung adapter
- For use on 15 – 55 gallon (50 – 205 litre) drums
- **Recommended use:** water-based fluids, antifreeze, Adblue®, urea, DEF, benzene, detergents, glycerine, acids, chemicals, oils, diesel, kerosene
- **Do not use with:** acetone, lacquer, mineral oils, solvents, turpentine, gasoline or fluids incompatible with wetted components
- Wetted components: polypropylene, Ryton®, Viton®, stainless steel

### Litre Stroke Pump

350115 / JLSP-100

- Designed to dispense exact amounts of petroleum based fluids
- Adjustment screw allows pump to be set to deliver 1 litre or 1 quart per stroke
- Rack and pinion mechanism is very precise; ideal for applications requiring metered delivery
- Spring loaded drain-back tube returns overflow to the drum via the suction tube
- Handle can be padlocked for security
- Lock nut allows outlet to be positioned in any direction
- Complete with 2" bung adapter
- For use on 15 – 55 gallon (50 – 205 litre) drums
- **Recommended for:** gear and lube oils, petroleum based fluids, diesel fuel, kerosene
- **Do not use with:** water based, corrosive fluid, gasoline or liquids incompatible with wetted components
- Wetted components: steel, aluminum, nitrile rubber and acetal

*Viton® is a registered trademark of DuPont Performance Elastomers LLC*

*Adblue® is a registered trademark of the VDA*

*Ryton® is a registered trademark of Chevron Phillips Chemical*

## Rotary Fuel Pump

350116 / JRFP-10

- Industry standard for rotary pumps
- Designed for severe use in extreme weather conditions
- Solid cast iron body CNC machined to exacting tolerances
- High quality sintered powder metal 3 vane rotor operates in a highly finished pumping chamber
- Non-wearing graphite vanes and graphite seal allows pumping of a wide variety of fluids including those with up to 15% ethanol
- Discharges up to 10 GPM (38 LPM)
- Complete with 2" bung adapter and telescopic suction tube with strainer
- **For use on 15 – 55 gallon (50 – 205 litre) drums**
- **Recommended use:** gear and lube oils, petroleum based fluids, diesel fuel, kerosene and gasoline
- **Do not use with:** water based, corrosive fluids or fluids incompatible with wetted components
- Wetted components: cast iron, steel, graphite, paper, polypropylene



**NEW**



**NEW**

## Rotary Fuel Pump Kit

350117 / JRFP-10K

- Industry standard for rotary pumps
- Designed for severe use in extreme weather conditions
- Complete with 8' anti-static discharge hose and non-sparking aluminum nozzle and nozzle holder for re-fueling operations
- Solid cast iron body CNC machined to exacting tolerances
- High quality sintered powder metal 3 vane rotor operates in a highly finished pumping chamber
- Non-wearing graphite vanes and graphite seal allows pumping of a wide variety of fluids including diesel with up to 15% ethanol
- Discharges up to 10 GPM (38 LPM)
- Complete with 2" bung adapter and telescopic suction tube with strainer
- **For use on 15 – 55 gallon (50 – 205 litre) drums**
- **Recommended for:** gear and lube oils, petroleum based fluids, diesel fuel, kerosene and gasoline
- **Do not use with:** water based, corrosive fluid, or fluids incompatible with wetted components
- Wetted components: cast iron, steel, graphite, paper, polypropylene





**NEW**

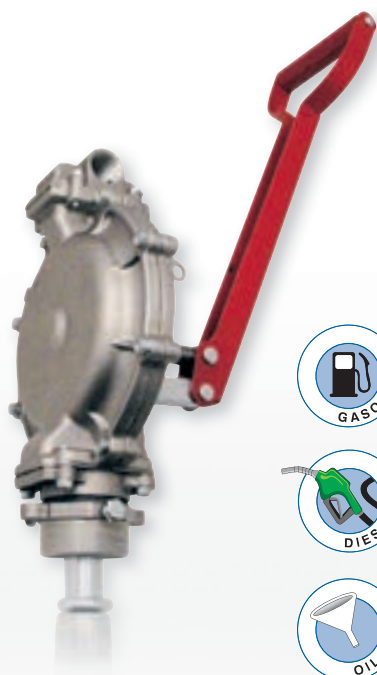

## FUEL AND GASOLINE PUMPS

### 3:1 High Volume Rotary Fuel Pump

350118 / JRFP-300

- Geared rotary barrel pump turns rotor 3 times for each turn of the handle
- Dispenses up to 55 gallons (205 litres) in just 3 minutes
- Ideal for use where volume fuel dispensing is required
- Die cast aluminum pump body with die cast zinc rotor and vanes
- Built-in nozzle holder
- Handle can be locked for security
- Complete with 6' fuel resistant discharge hose
- Complete with 2" bung adapter and 3 piece threaded tube
- **For use on 15 – 55 gallon (50 – 205 litre) drums**
- **Recommended use:** gasoline, diesel fuel, and kerosene
- **Do not use with:** water based or corrosive liquids, solvents, acids, alkalis or fluids incompatible with wetted components
- Wetted components: aluminum, zinc, steel, NBR and PVC Nitrile

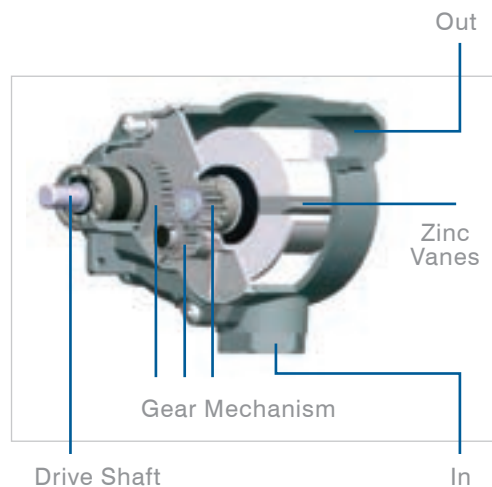

### Diaphragm - Litre Stroke - Heavy Duty

350107 / JDDP-1000

- High volume double action pump delivers on both strokes for fast fuelling
- Delivers 1 litre per cycle or 1 gallon / 5 strokes
- **Fits 15 – 55 gallon drums**
- Die cast aluminum construction
- Stainless steel piston and fuel resistant diaphragm
- Extra heavy duty steel handle with security locking latch
- Complete with 2" bung adaptor, 8' discharge hose and telescoping suction tube
- **Recommended use:** gasoline, diesel fuels, fuel oil, motor oil
- **Do not use with:** corrosive liquids, solvents, alkalis, or fluids incompatible with wetted components
- Wetted components: aluminum, steel, stainless steel, polyacetal, NBR

# OIL DRAINS

**NEW**



## 90 Litre Waste Oil Drain - Heavy Duty 350511 / JOIDR90

- Large 90 litre steel recovery tank
- 78" long drainage hose
- Tank mounted oil-level sight gauge
- Convenient tool tray
- 16" diameter collection funnel holds 18 litres of oil
- 23" diameter collection funnel adaptor included to expand oil catch area
- Shut off valve between collection funnel and tank allows fluid inspection prior to draining oil
- Uses air to pressurize tank, allowing quick and easy fluid evacuation (maximum 7 PSI)
- Pressure regulator included
- Adjustable bowl height from 40" to 79" high
- Uses gravity to drain waste oil from engines, gear boxes, and differentials
- Shipping weight: 60 lb (27 kg)





**NEW**



## OIL DRAINS

### 18 US Gallon (68 Litre) Waste Oil Drain

350512 / JOIDR68GD

- 68 litre steel recovery tank
- 8' drainage hose doubles as an oil level sight gauge
- 14" metal collection funnel holds 10 litres of oil
- Shut off valve between funnel and tank allows fluid inspection prior to draining oil
- Uses air to pressurize tank, allowing quick and easy fluid evacuation (maximum 10 PSI)
- Pressure regulator included
- Adjustable bowl height from 46 to 75"
- Uses gravity to drain waste oil from engines, gear boxes and differentials
- Shipping weight: 58 lb (26 kg)



**NEW**

### 17 US Gallon (64 Litre) Low Profile Polypropylene Oil Drain

350514 / JOIDRLP

- Ideal for draining oil where a pit or hoist is not available
- 17 US Gallon tank with integrated baffle captures oil and minimizes spillage during transport
- Convenient rotary hand pump for fast evacuation to large oil collection tanks
- Large metal screen keeps foreign matter out of recovery tank
- Long steel handle eases moving and positioning of drain
- Shipping Weight: 46 lb (21 kg)



**NEW**

### 15 US Gallon (56 Litre) Low Profile Steel Tank Oil Drain

350515 / JOIDRLPM

- Ideal for draining oil where a pit or hoist is not available
- 15 US Gallon tank with integrated baffle captures oil and minimizes spillage during transport
- Convenient rotary hand pump for fast evacuation to large oil collection tanks
- Large metal screen keeps foreign matter out of recovery tank
- Long steel handle eases moving and positioning of drain
- Shipping Weight: 46 lb (21 kg)



**NEW**

### 17 US Gallon (64 Litre) Low Profile Polypropylene Antifreeze Drain

350520 / JOIDRLPAF

- Ideal for draining antifreeze where a pit or hoist is not available
- 17 US Gallon tank with integrated baffle captures antifreeze and minimizes spillage during transport
- Convenient rotary hand pump for fast evacuation to large collection tanks
- Aluminum pump body specifically designed to pump corrosive antifreeze
- Large metal screen keeps foreign matter out of recovery tank
- Long steel handle eases moving and positioning of drain
- Shipping Weight: 46 lb (21 kg)



## Drum Wrench - Aluminum Handle

350214 / JADW-1

- Designed to fit perfectly onto most 2" and 3/4" drum plugs
- Made of cast aluminum for strength and safety
- Will not cause sparks
- Hardened and tempered



## Drum Dollies

- Heavy gauge steel for professional use
- Powder coated finish
- 5 and 16 gallon models with adjustable clamp bolt
- 16 and 55 gallon models complete with cast iron casters
- Cast iron casters (**351005**)

PROD. NO.	MOD. NO.	Application	Wheels	Load Limit	Diameter
<b>351003</b>	JDD-5	<b>5 gallon drums</b>	Resin	200 lbs	10-1/4 – 11-1/4"
<b>351004</b>	JDD-16	<b>16 gallon drums</b>	Super Heavy Duty Cast Iron	200 lbs	13-1/2 – 14-1/4"
<b>351005</b>	JDD-55	<b>55 gallon drums</b>	Super Heavy Duty Cast Iron	450 lbs	23"



## Drum Cradle

351011 / JDC-55

- Tilting drum cradle moves, rotates, tips and stores 55 gallon drums with ease
- Self storing lever bar
- Powder coated finish
- Flat packed for easy shipping
- 2-1/2" non-sparking wheels
- Load limit: 600 lb (270 kg)





500AMP  
CARBON PILE  
LOADTESTER

- CHECK BATTERY STATE OF CHARGE.
- APPLY LOAD TO BATTERY SERIAL TO 1/2 CCA RATING OR STRONGER THE SOVER RATING.
- HOLD LOAD FOR 15 SECONDS.
- READ VOLTAGE.
- TURN OFF LOAD.

JET

LOAD

TESTS 12V  
ALTERNATE  
& STARTER

WARNING  
DANGEROUS! USE  
PROTECTIVE HEAD  
WEAR. DO NOT  
LOOK INTO THE  
LOADS WHEN  
PLUGGED IN.  
DO NOT TOUCH  
INTERNAL PARTS  
WHEN POWER  
IS ON.

WODEF

500AMP  
CARBON PILE  
LOADTESTER



# Specialty Automotive

AIR CONDITIONING SERVICE  
AUTOMOTIVE GAUGES  
BATTERY SERVICE  
BEARING & BUSHING TOOLS  
BRAKE SERVICE  
COOLING SYSTEM  
ELECTRICAL SYSTEM  
ENGINE SERVICE  
EXHAUST SYSTEM  
FASTENER TOOLS  
FUEL/INJECTION SYSTEM  
HAND TOOLS

HEAD AND VALVE REPAIR  
HONES  
OIL FILTER/  
DRAIN PLUG TOOLS  
PICK-UP TOOLS/  
MAGNETS/MIRRORS  
SENSOR & SENDER UNITS  
SUSPENSION/  
DRIVE TRAIN REPAIR  
TIRE SERVICE  
UPHOLSTERY/TRIM PANEL  
/WINDSHIELD TOOLS



## BRAKE REPAIR TOOLS

### Brake Adjusting Tool - Universal

H1085



- Ground and tapered for easy access to most applications
- Lustre plated for rust protection
- Blade width: **5/8"**
- Overall Length: **9"**

### Brake Adjusting Tool - Short

H1107



- This short length tool is popular as it gets into many tight spots found on today's cars
- Curved and ground for universal use
- Lustre plated for rust protection
- Blade width: **1/2"**
- Overall Length: **7"**

### Brake Shoe Retaining Spring Tool

H1096



- *DUAL SIZE FOR DISH TYPE WASHERS*
- Used for removing the dish type washer on brake shoe hold down spring
- Knurled cup securely grips washer
- Notched for washer with ears
- Fits many imports with smaller hold down springs
- Plastic handle
- Bright lustre plated
- Range: **5/8 - 7/8" diameter washers**

### Brake Spring Pliers

H1103



- Removes and installs brake springs on majority of cars and trucks
- Forged from alloy steel and heat-treated for long wear
- Designed with narrow points for inline pull on the springs
- Equipped with special Bendix® socket on one end
- Overall length: **13"**

### Rear Disc Brake Piston Tool

H3070

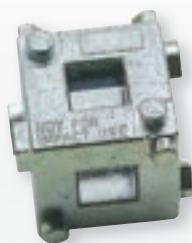

- Designed to rotate the rear parking brake piston back into the caliper cylinder when replacing worn brake pads on vehicles equipped with four wheel disc brakes
- Will work on most Ford®, Chrysler®, some GM® models, and some imports

# TUBE BENDERS & CUTTERS



## Tube Cutter - Micro (5/8" O.D.)

H1179

- Cut copper tubing in close quarters
- Cutter will turn on 1-5/8" radius
- Cuts copper tubing 1/8" - 5/8" O.D.

### REPLACEMENT CUTTER WHEEL:

- **739191** - Copper, brass, aluminum and thin wall steel tube
- **739193** - Stainless Steel

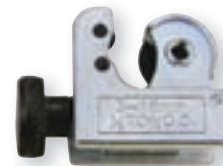

## Tube Bender - Heavy Duty

H1278

- Bend thin wall tubing 360° with this heavy duty bender
- For use in automotive, plumbing, heating, refrigeration and marine applications
- Range: **1/8" - 1/2" O.D. tubing**



## Plier Type Tube Bender - Heavy Duty

H3342

- Bends copper or steel tubing without kinking or collapsing
- Comes with two roller adaptors
- Bends **3/16", 1/4", 5/16", 3/8"** tubing





# FLARING TOOL KITS



## Double Flaring Tool Kit S.A.E. H1120

- Built to provide the necessary pressure to double flare steel brake tubing
- Will double and single flare both copper and steel tubing
- Double flare adaptors provided for 3/16, 1/4, 5/16, 3/8 and 1/2" tubing
- Alloy steel swivel is heat-treated, ground, and chromed to reduce compression friction
- Yoke and bar is forged and tempered for added strength

**Kit Includes:**

- |                                                 |                                                |
|-------------------------------------------------|------------------------------------------------|
| <b>H1120A</b> Double Flare adaptor <b>3/16"</b> | <b>H1120E</b> Double Flare adaptor <b>1/2"</b> |
| <b>H1120B</b> Double Flare adaptor <b>1/4"</b>  | <b>H1120F</b> Bar Assembly                     |
| <b>H1120C</b> Double Flare adaptor <b>5/16"</b> | <b>H1120G</b> Yoke and Bolt Assembly           |
| <b>H1120D</b> Double Flare adaptor <b>3/8"</b>  | <b>H1120H</b> Wingnut                          |



## Double Flaring Tool Kit Metric H1121

- Built to provide the necessary pressure to double flare steel brake tubing
- Will double and single flare both copper and steel tubing.
- Double flare adaptors provided for 4.75, 5, 6, 8, 10 mm tubing
- Alloy steel swivel is heat-treated, ground, and chromed to reduce compression friction
- Yoke and bar is forged and tempered for added strength

**Kit Includes:**

- |                                                   |                                                 |
|---------------------------------------------------|-------------------------------------------------|
| <b>H1121A</b> Double Flare adaptor <b>4.75 mm</b> | <b>H1121E</b> Double Flare adaptor <b>10 mm</b> |
| <b>H1121B</b> Double Flare adaptor <b>5 mm</b>    | <b>H1121F</b> Bar Assembly                      |
| <b>H1121C</b> Double Flare adaptor <b>6 mm</b>    | <b>H1121G</b> Yoke and Bolt Assembly            |
| <b>H1121D</b> Double Flare adaptor <b>8 mm</b>    | <b>H1120H</b> Wingnut                           |

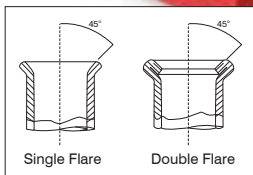

## Double Flaring and Cutting Tool Kit 739181 / JTFK-100

- Includes JTC-30 Tubing Cutter, JFT-100 Flaring Tool and Double Flaring Inserts for 3/16, 1/4, 5/16, 3/8, 7/16, 1/2 and 5/8" tube
- Provides automotive type double flare or use without inserts for 45° flare
- Cuts up to 1-1/8" (30 mm) tube
- For soft copper, brass and aluminum tube
- Complete with blow mould storage case
- Replacement Double Flaring Dies:

- |                       |                       |
|-----------------------|-----------------------|
| <b>3/16" – H1120A</b> | <b>7/16" – H1120J</b> |
| <b>1/4" – H1120B</b>  | <b>1/2" – H1120E</b>  |
| <b>5/16" – H1120C</b> | <b>5/8" – H1120K</b>  |
| <b>3/8" – H1120D</b>  |                       |



**I.S.O. Bubble Flaring Tool Kit** **H1502**

- Front wheel drive cars and light trucks, both foreign and domestic, are installing I.S.O. sized steel brake lines with the I.S.O. flare. This is different from the standard double flare
- Accomplishes the I.S.O. flare without removing the brake line from the vehicle, and it has the strength to withstand the pressure necessary to flare mild steel tubing (1.0mm wall thickness) used on the front wheel drive brake line
- Yoke is made of a heat treated, alloy steel drop forging, with a special patented center screw
- Bar assembly is hardened and will hold up under repeated use and produces a smooth, consistent flare
- Kit is complete with flaring tool, four special adaptors, a chamfering tool and a combination wrench and height gauge

**Kit Includes:**

- |                                      |                             |
|--------------------------------------|-----------------------------|
| <b>H1502A</b> Adaptor <b>4.75 mm</b> | <b>H1502E</b> Bar Assembly  |
| <b>H1502B</b> Adaptor <b>6 mm</b>    | <b>H1502F</b> Yoke Assembly |
| <b>H1502C</b> Adaptor <b>8 mm</b>    | <b>H1502G</b> Reamer        |
| <b>H1502D</b> Adaptor <b>10 mm</b>   | <b>H1502H</b> Wrench        |

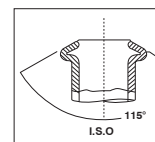

## BRAKE REPAIR TOOLS

**Deluxe Vacuum Pump with Bleeder Kit** **H3502**

- Checks vacuum operated components on all vehicles including distributor advance mechanism, heater and air conditioning baffles, PCV and EGR valves, headlight cover doors, transmission modulators and more
- Allows you to bleed brake fluid by yourself

**Kit includes:**

- Fluid resistant valve pump, easy reading gauge head, reservoir jar, transfer and storage lids, rubber cup adaptor, two 2' lengths of tube, brake bleeding adaptors for most vehicles
- Replacement Parts:

- |                                      |                               |
|--------------------------------------|-------------------------------|
| <b>H3502-10</b> Gauge Head           | <b>H3502-12</b> Adaptor Kit   |
| <b>H3502-11</b> Bleeder Cup and Caps | <b>H3502-13</b> Pump Seal Kit |



**11 PC Disc Brake Caliper Tool Set** **H3444**

- Used to install new rear brake pads by winding the piston back into the caliper
- May be used "on" or "off" the vehicle
- Piston retraction is completed smoothly without damaging the piston or boot
- Includes 9 adaptors for use on 2 and 4 wheel rear disc brake assemblies
- Designed for use with Mercedes®, BMW®, Volkswagen®, GM®, Audi®, Ford®, Honda®, Subaru®, Mazda®, Nissan®, Mitsubishi®, Toyota®, Land Rover®, and 4 wheel drive vehicles
- Comes in convenient blow mould storage case







**Small Brake Cylinder Hone (1/2" - 2-1/2" Range) H1841**

- For sub-compact cars, including imports
  - For cylinder bores 1/2" to 2-1/2" diameter
  - Offers fast, easy cutting with high or low speed drill
  - Self-aligning, self-centering flex joint drive
  - Adjustable tension
- Replacement Stones:
- **H1841A** Set of 2 : Medium, **220 Grit**, Stone Length 1-1/8"



**Engine Hone (2 – 7" Range) H1843**

- 3 stone adjustable tensions
  - Designed for fast accurate deglazing of cylinders
  - Operated by any 1/4" – 1/2" electric drill
  - Powerful arm design keeps the abrasives accurately in line
  - Spring tension adjusting nut for positive cutting action at all speeds
  - Full range **2" – 7"** (51-178mm) capacity equipped with three 220 grit stones recommended for ring seating
- Replacement Parts:
- **H1843A** Replacement Stones Set of 3: Medium, **220 Grit**, 4" Long
- Accessory Stone Sets:
- **H1843E** Set of 3: Coarse, **100 Grit**, 4" Long
  - **H1843F** Set of 3: Fine, **400 Grit**, 4" Long

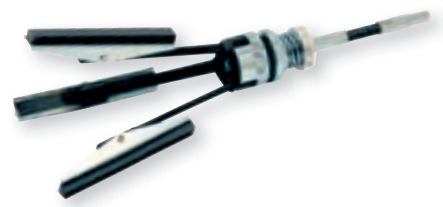

**Brake Cylinder Hone (3/4 - 2-1/2" Range) H1844**

- 3 stone adjustable tensions
  - Designed for fast accurate deglazing of cylinders
  - Operated by any 1/4" - 1/2" electric drill
  - Powerful arm design keeps the abrasives accurately in line
  - Spring tension adjusting nut for positive cutting action at all speeds
  - Full range **3/4" - 2-1/2"** capacity equipped with three 220 grit stones recommended for ring seating
- Replacement Stones:
- **H1844B** Set of 3: Medium **220 Grit**, Stone Length 1-1/8"



**Small Engine Hone (1" - 3" Range) H1864**

- Flexible drive shaft permits easy access to all cylinders
- Cone expansion adjusts hone to cylinder wall with uniform pressure
- Adjustable spring tension to select desired pressure
- Fits standard 1/4" or 3/8" drill
- Range: **1" - 3"** cylinder diameter
- No extensions required
- Supplied with 180 grit 2" stones recommended for quick, positive seating of all piston rings
- Replacement Stone Kit: **H1864C** Set of 3: **180 Grit** 2" Long
- Optional Stone Kit: **H1844E** Set of 3: **220 Grit** 2" Long





## BEARING PACKERS

### Wheel Bearing Packer

H3047

- For use with grease guns
- Works on all wheel bearings having a **minimum I.D. of 1/2"** to a **maximum O.D. of 5"**
- Height of **1/4" - 2"**
- Place bearing between cones and tighten. Old grease is forced out as new grease is pumped in under pressure
- Use hand or power equipment

### 10 PC Bearing Race and Seal Driver Set

H3437

- Inserts bearing race and seals quickly, straight and without damaging both race and axle housings on the first try
- Collars fit most standard wheel bearing sizes
- Comes in convenient blow mould storage case

#### Set includes:

- 9 Disc Sizes: **1.565, 1.750, 1.965, 2.325, 2.470, 2.555, 2.830, 2.995, 3.180"**
- 1 heavy duty driver handle



### 18 PC Universal Driver Set

H3538

- Includes most popular size drivers for proper installation of seals, bearings, bushings
- Ensures even distribution of force to all areas and prevents cocking
- Comes in convenient blow mould storage case

#### Set Includes:

- 12 Drivers: **5/8, 3/4, 7/8, 1, 1-1/8, 1-1/4, 1-3/8, 1-1/2, 1-5/8, 1-3/4, 1-7/8, 2"**
- 1 handle, 4 cap screws, 1 hex key



# FRONT WHEEL DRIVE AXLE NUT TOOLS



**7 PC Axle Nut Socket Set** **H3533**

- Sockets made of high quality, Chrome Molybdenum steel for best performance and life
- Sockets are **1/2" drive** and are extra long in order to adequately access FWD spindle nuts
- May be used with air and electric impact wrenches, ratchets, flex and breaker bars and with torque wrenches
- Comes in convenient blow mould storage case
- Includes: **29, 30, 32, 34, 35, 36 and 38 mm**



**Axle Nut Socket – Open Stock**

<b>H3149</b>	<b>29 mm</b>	Services late model GM®, Ford® and Asian imports including the Escort® and Fiesta®
<b>H3150</b>	<b>30 mm</b>	Services GM® "A", "J", "N" and "X" body cars and some Asian imports
<b>H3151</b>	<b>32 mm</b>	Services late model Honda® and Chrysler® cars
<b>H3152</b>	<b>34 mm</b>	Services late model GM®, Buick®, Cadillac®, Chevy®, Oldsmobile® and Pontiac® cars
<b>H3308</b>	<b>35 mm</b>	Services many late model GM® cars
<b>H3153</b>	<b>36 mm</b>	Services GM® "E" style cars
<b>H3309</b>	<b>38 mm</b>	Services a variety of full size vehicles including many SUV's



H3153



## TRUCK WHEEL BEARING LOCKNUT SOCKETS

- Specially designed sockets used for the quick and easy removal of truck wheel bearing locknuts
- Made from high quality steel which resists "rounding out"
- Available in 6 point hexagon, 8 point octagon and special "rounded" shape for Dana axles
- All sockets are **3/4" drive**
- For use with manual ratchets, flex and breaker bars, and torque wrenches
- **NOTE:** Do not use with any air or electric impact tools

**6 Point Hexagon Style**

<b>H2150</b>	<b>2-3/32"</b>	<b>H2155</b>	<b>3"</b>
<b>H2169</b>	<b>2-1/4"</b>	<b>H2157</b>	<b>3-1/4"</b>
<b>H2151</b>	<b>2-3/8"</b>	<b>H2159</b>	<b>3-1/2"</b>
<b>H2170</b>	<b>2-1/2"</b>	<b>H2186</b>	<b>3-3/4"</b>
<b>H2171</b>	<b>2-5/8"</b>	<b>H2161</b>	<b>3-7/8"</b>
<b>H2153</b>	<b>2-9/16"</b>	<b>H2163</b>	<b>4"</b>
<b>H2172</b>	<b>2-3/4"</b>	<b>H2164</b>	<b>4-1/8"</b>
<b>H2179</b>	<b>2-7/8"</b>		

**Special Rounded Hexagon Style** **H2177**

- This special "rounded" hex truck wheel bearing locknut socket is used on Dana® axles
- **2-9/16"**

**8 Point Octagon Style**

<b>H2158</b>	<b>3-1/4"</b>
<b>H2188</b>	<b>3-3/4"</b>
<b>H2176</b>	<b>3-13/16"</b>
<b>H2162</b>	<b>3-7/8"</b>
<b>H2166</b>	<b>4-3/8"</b>
<b>H2168</b>	<b>4-7/8"</b>



## FOUR WHEEL DRIVE SPINDLE LOCKNUT TOOLS

### 6 Pin 2-5/8" Outer Style Locknut Socket

H1486

- 1978 to current Ford® 4/4 ton vehicles
- 1973 to 1981 GM 3/4 ton vehicles

### 4 Pin 2-1/4" Inner Style Locknut Socket

H3406

- 1960 to current 1/2 ton Chevrolet® and GMC®
- 1966 to current Bronco®, Blazer® and Scout®
- 1959 to current Ford® F150-250 series
- 1969 to current Dodge® 1/2 ton vehicles

### 4 Pin 2-3/4" Outer x 1-9/16" Style Locknut Socket

H3405

- 1985 to late Ford® F250-350 truck rear axle with hi-Ssear rotating nut and Ford® Dana 80 truck rear axles



### 3 Step Spindle Remover Tool

H3604

- Pulls out 4WD spindles for lubricating the inner needle bearing and front wheel alignment
- Fits common 1/2 and 3/4 ton 4WD pickup spindles
- 3 step design fits 1-1/2", 1-5/8" and 2" spindles
- Use with 1/2" - 20 or 5/8-18 thread slide hammer





## FOUR WHEEL DRIVE SPINDLE LOCKNUT TOOLS

### 4 Pin 2-3/8" Outer Style Locknut Socket

**H3107**

- 1986 to current Ford® Bronco® and Ranger® with Dana axles
- 1960 to current 1/2 ton Chevrolet® and GMC®
- 1966 to current Bronco®, Blazer® and Scout®
- 1959 to current Ford® 100-250 series
- 1969 to current Dodge® 1/2 ton vehicles

### 4 Pin Toyota® Style Locknut Socket

**H3601**

- Toyota® 1995 and newer Tacoma, 1996 and newer T100 and 4-Runner

### 4 Pin 2-1/2" Inner Style Locknut Socket

**H3407**

- Used on 1/2 and 1 ton 4WD vehicles





## FRONT END SERVICE TOOLS

### 5 PC Front End Service Kit

H3540

- Complete front end service tool kit for easy removal of most pitman arms, tie rods & ball joints
- Includes a press type separator for ball joint removal without damage to boots and other parts
- An absolute must for all front end service shops
- Comes in convenient blow mould storage case

**Kit includes:**

- **H1926** Pitman Arm/Tie Rod End Puller
- **H3609** Pitman Arm Puller
- **H3612** Tie Rod/Inner Bearing Race Puller
- **H3614** Ball Joint Separator
- **H3616** Ball Joint/Tie Rod End Remover



### 5 PC Pickle Fork Kit

H3448

- A multi-purpose kit that features all the tools required to separate most ball joints, tie rods, pitman arms and shock absorber links
- 3 heavy duty forks are made from drop forged, heat treated steel
- 2 drive handles are made from alloy steel – one handle for use with regular hammers, the other features a .401 shank for use with most popular air hammers
- Forks can be used with either drive handles
- Pilot head designed handles absorb shock and protect threads from distortion

**Kit includes:**

- Tie Rod Separator Opening **11/16"**
- Ball Joint Separator Opening **15/16"**
- Pitman Arm Separator Opening **1-1/8"**
- Alloy Handle - for use with regular hammers length 8"



### Pitman Arm Puller – Heavy Duty

H3609

- Specially designed jaws fit the job and ensures firm grip
- Extra wide opening of **1-3/8"**
- Pull **3-1/2"**



### Pitman Arm/Tie Rod End Puller

H1926

- For use on small cars having smaller pitman arms and tie rod ends
- Can also be used for rack and pinion steering removal
- Opening: **1-1/16"**
- Pull: **1-3/4"**



### Ball Joint/Tie Rod Remover

H3612

- Swivel centering pin ensures a strong, positive pull
- Tool directly attaches to stud for easy and convenient use
- Fits most front wheel drive vehicles and light trucks
- Opening: **3/4"**
- Pull: **1-1/2"**



### Ball Joint Separator - Universal Application

H3614

- Heavy duty "scissor" design suits most cars and light trucks
- Easily separates press fit ball joints
- 2-stage height adjustment feature uses a heat treated steel pin thrust bolt and steel ball insert, allowing quick and easy height adjustment changes
- The combination of the "scissor" design and the 2-stage height adjustment offers maximum versatility
- Can be used on most press fit ball joint applications



## 4 PC Inner Tie Rod Removal Kit

**H3061**

- The tool kit contains everything necessary to directly remove and install the inner tie rod without the hassles of removing the steering gear
- Works on most inner tie rod structures
- Made of heavy duty alloy steel, black oxide finish
- Comes in convenient blow mould storage case



## Outer Tie Rod Remover

**H3616**

- The adjustable jaw can spread to match tie rods of various sizes
- Removes the outer tie rod from the steering knuckle
- The custom designed jaw tips ensure maximum grip and withstands up to 5 tons of pulling force!
- The use of this mechanical screw puller ensures an evenly distributed pulling force, eliminating damage to existing parts
- Ideal for use on import and domestic cars with front and rear wheel drives with stamped or cast steel steering knuckles
- Opening: **0 to about 7"**
- Pull: **4"**



## Dual Socket Inner Tie Rod Tool

**H3060**

- Features a double ended "stepped" socket
- **1-3/16" hex** fits primarily Ford® (FWD) and Renault®
- **1-5/16" hex** fits primarily GM®, AMC®, Chrysler® and Ford® (RWD)
- 1/2" Square Drive



## Dual Inner Tie Rod Adaptor For H3060/H3061 (1-7/16")

**H3071**

- **1-7/16" adaptor** for GM® and Chrysler® cars with Saginaw® steering gear
- Use with H3060 Dual Inner Tie Rod Tool

**H3071A**

**1-3/16" Adaptor** for H3060 and H3061

**H3071B**

**1-5/16" Adaptor** for H3060 and H3061

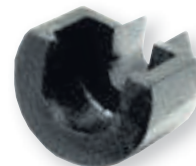

## Ball Joint Separator (15/16" Opening)

**H1902**

- Removes ball joints from connecting links
- Just a few sharp blows with a hammer and the tapered prongs easily separates the parts
- Opening: **15/16"**
- Length: **12"**



## Tie Rod End Separator (21/32" Opening)

**H1907**

- Removes tie rod ends from connecting links
- Just a few sharp blow with a hammer and the tapered prongs easily separates the parts
- Opening: **21/32"**
- Overall Length: **16"**



## Ball Joint Master Service Kit

H3536

- This master kit covers most press-fit vehicle joint components
- Used to service the removal/installation of ball joints, universal joints, truck brake anchor pins and 4WD ball joints
- C-frame alone can be used to remove/replace universal joints
- Tool can remove rusted and corroded parts
- Comes in convenient blow mould storage case

### Kit includes:

- Heavy duty C-frame and forcing screw (1.106" x 7 threads per inch)
- Receiver tubes and receiving/installation adaptors to work on press fit upper and lower ball joints on most Dodge® Ram, Ford®, GM®, IHC® and Jeep® 2 and 4 wheel drive pick-up trucks, SUV's and vans (auto's with Dana front axles)



## MacPherson® Strut Coil Spring Compressor Kit

H1560

- Allows you to quickly compress the coil spring to replace shock absorbers, spring sets, repair bent strut or strut tube and repair damaged spindle
- Designed to be used on virtually all modern domestic and imported vehicles that use MacPherson® struts
- Do not use on GM® "A", "J", or "X" body cars or coil springs that exceed a 6" outside diameter

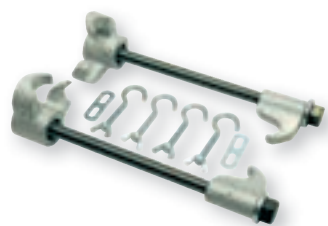

## C.V. Boot Clamp Pliers - Earless

H1084

- For earless type clamps
- Ratchet will lock for easy use



## Ball Joint 4-in-1 Service Kit

H3537

- For press-fit vehicle joint components
- Heavy duty, four function kit to service the removal/installation of ball joints, universal joints, truck brake anchor pins and 4WD ball joints
- Both ball joint and 4WD ball joint service can be done without taking the control arm off
- U-joint service can be performed on needle type U-joint bearings
- Truck anchor pin service can be performed with pins up to 1-1/4" diameter
- Services 4WD ball joint equipped vehicles including those vehicles with Dana® 44 front axles such as 1967 to current 1/2 ton and 3/4 ton Dodge®, GM®, Ford®, IHC®, Jeep®
- Tool will even remove rusted and corroded parts
- C-frame alone can be used to remove/replace universal joints
- Comes in convenient blow mould storage case

### Kit Includes:

- Heavy Duty C-frame and forcing screw (1.106" x 7 threads per inch)
- Installation and removal adaptors
- Installation cup adaptor
- Receiving and installation cups
- 3 Receiver tubes: 2-3/4" x 2-1/4", 2-1/4" x 1-3/4", 1-3/4" x 1-3/4"



## MacPherson® Strut Deluxe Coil Spring Compressor Kit

H3315

- Built-in detent pins to help lock the coil in place eliminating the need for extra safety hooks. Set up is faster and easier
- Improved design
- Comes in convenient blow mould storage case



## C.V. Boot Clamp Pliers - Eared

H1088

- For eared type clamps
- Unique design allows user to clamp ring and then use a torque wrench in 1/2" square drive holes in handle to accurately set clamp
- Plunger can be deactivated





## 1/4" Drive Flexible Radiator Hose Clamp Driver H3319

- Multi-use, flexible-shaft, 1/4" drive socket driver
- 12" Overall length shaft will tighten or loosen hex head screws on gear type hose clamps and other applications in even the most hard to get at places
- 1/4" drive end allows operator to attach any 1/4" drive socket to fit the job



## Hose Clamp Pliers - Flexible Flat Band Type H3290

- Designed to access the flat-type hose clamps located in hard-to-reach areas
- Pliers have locking mechanism to hold clamp in the open position - for easy removal and installation of clamp
- Spring loaded handles
- Heavy-duty 24" cable flexes to almost any position
- Range: **0 - 2-1/16" (0 - 53mm)**
- AOL Length: **33"**
- Replacement Part: **H3290-10** Cable Assembly



## 3 PC Hose Pinch-Off Pliers Set H3318

- For use on all brake and fuel hose lines
- Special rounded edges ensure no damage to lines or internal reinforcements
- Lightweight and non-conductive
- Three sizes for use on most jobs

### Set Includes:

- **H3140** Capacity **1/4" - 7/16" (6 - 12mm)**
- **H3316** Capacity **1/2" - 3/4" (13 - 19mm)**
- **H3317** Capacity **3/4" - 2-1/4" (19 - 57mm)**





## HOSE & CLAMP TOOLS

### Small Hose Pinch-Off Pliers (1" Capacity)

H3128

- No need to drain system when changing thermostats. Save coolant - save time
- Jaws swivel for parallel clamping. Heat treated
- Steel arms automatically lock with ratchet
- May also be used to pinch off vacuum lines
- Overall Length: **10"**
- Capacity: **Up to 1"**
- Note: Not for use on wire reinforced radiator hose

### Large Hose Pinch-Off Pliers (1-3/8" Capacity)

H3129

- No need to drain system when changing thermostats. Save coolant - save time
- Jaws swivel for parallel clamping. Heat treated
- Steel arms automatically lock with ratchet
- May also be used to pinch off vacuum lines
- Overall Length: **12"**
- Capacity: **Up to 1-3/8"**
- Squeezes wire reinforced radiator hose

## FAN CLUTCH WRENCHES

### 10 PC Fan Clutch / Water Pump Wrench Set

H3530

- Removes and installs fan clutches and water pumps on most Chrysler®, Ford® and GM® vehicles
- Holding wrench immobilizes the fan clutch. The nut wrench turns the nut on or off
- Works in tight spaces where conventional wrenches won't reach
- Heat-treated for strength and durability
- Use with 1/2" drive ratchet or breaker bar for more torque

#### Set includes:

- Fan Pulley Holding Tool: **2-1/4"** and **3-1/4"**
- Fan Clutch Bolt Holding Tool: **2-3/8"**
- Fan Clutch Pulley Holding Tool: **2-1/8"** and **3"**
- Fan Clutch Nut Wrench: **1-7/16"**
- Fan Clutch Wrench: **1-7/16"** and **1-9/16"**
- Fan Hub Wrench: **2-13/16"**
- Clutch Nut Wrench (left hand): **1-7/8"**
- Comes in convenient blow mould storage case



## 4 PC Fan Clutch Wrench Kit

H3531

- Designed for removing and installing fan clutch assemblies on most Ford® engines
- Holding wrench immobilizes the fan clutch. The nut wrench turns the nut on or off
- Works in tight spaces where conventional wrenches won't reach
- Heat treated for strength and durability
- Use with 1/2" drive ratchet or breaker bar for more torque
- The small double-ended wrench is for 2.8, 2.9, 3.0, 4.0 and 4.9 litre engines
- The large single-ended wrenches and large holding wrench are for 6.9 and 7.3 litre diesel engines

### Kit Includes:

- Double-ended Fan Clutch Wrench: **36mm** and **1-9/16"**
- Fan Clutch Holding Wrench: **58mm**
- Fan Clutch Holding Wrench: **1-7/8"**
- Fan Clutch Holding Wrench: **3-1/4"**
- Comes in convenient blow mould storage case



## 14 PC Deluxe Serpentine Belt Tool Kit

H3529

- Enables rapid and easy removal and installation of belts on serpentine belt equipped vehicles
- Connect the tool to the spring loaded idler pulley to release the tension
- Fits most vehicles

### Kit Includes:

- Serpentine belt tool with cushion grip
- Extension Bars: **6"** and **10"** - for versatility and leverage
- Sockets: **13, 14, 15, 16, 18mm** - with custom 16mm drive end to fit bars
- 3/8" and 1/2" Drive adaptors - with custom 16mm drive end to fit bar
- 3/8" Drive Crowfoot Wrenches **13, 14, 15mm** - use with 3/8" adaptor above
- 3/8" - 16 UNC Bolt - to attach extension bars to long handle
- Comes in convenient blow mould storage case



## Compression Tester Gas Engines

**H1730**

- Quick disconnect flexible hose
- This quality, accurate tester has an angle construction tip to permit easy reading on back cylinders.
- The most popular type in use today
- The heavy duty neoprene hose bends in all directions for hard-to-reach cylinders

## Compression Tester Gas Engines

**H1731**

- Same features as H1730 without quick disconnect flexible hose
- Handy side release valve allows multiple readings on the same cylinder without removing the tester from the cylinder
- Hose assembly will disconnect easily from the gauge head to allow more flexibility and easier installation into spark plug holes

## Accessories - Replacement Parts

<b>H1730B</b>	Quick Coupler - H1730
<b>H1730C</b>	Hose Assembly Fits - H1730/H1731
<b>H1730D</b>	Long 14 mm Adaptor-H1730/H1731

<b>H1730E</b>	10 mm Adaptor - H1730/H1731
<b>H1730F</b>	12 mm Adaptor - H1730/H1731
<b>H1730H</b>	16 mm Adaptor - H1730/H1731



## Cylinder Leak Down Tester

**H3042**

- Tests for worn or broken rings, defective intake and exhaust valves, scored or cracked cylinders, leaky head gaskets and worn or stripped spark plug threads by measuring the amount of compressed air held in an engine cylinder
- Easy to use on all 2 and 4 cycle gasoline and diesel engines
- Dual gauges allow you to monitor input air line pressure up to 100 PSI
- Unit has precision pressure regulator to adjust pressure in cylinder to "set" area on regulator gauge
- Regulator gauge will read percentage of leak down in cylinder while the input pressure gauge assures that input pressure is steady

## Replacement Parts

<b>H3042A</b>	Gauge Head - H3042
<b>H3042B</b>	Regulator - H3042
<b>H3042C</b>	Leakage Gauge - H3042
<b>H3042D</b>	11-1/4" Hose Assembly with 14 and 18mm Adaptors
<b>H3042K</b>	Diesel Hose Adaptor for H3042

## Accessories

<b>H1730E</b>	10 mm Adaptor - H1730/H1731
<b>H1730F</b>	12 mm Adaptor - H1730/H1731
<b>H1730H</b>	16 mm Adaptor - H1730/H1731

## Vacuum and Pressure Tester

H1728

- 2-1/2" Chrome plated vacuum tester aids diagnosis of engine problems such as sticky valves, timing, carburetion, faulty fuel pump, and other vacuum-operated devices
- Brass adaptor fitting provided
- Pressure Range: **0 - 15 PSI, 0 - 1 kg/cm<sup>2</sup>**
- Vacuum Range: **0 - 30 in., 0 - 76cm HG**

### Replacement Parts:

- **H1728A** Gauge Head

**⚠ CAUTION:** Do not use on fuel injected vehicles



## Oil Pressure Tester

H3041

- Check oil pressure in automatic transmissions and engines
- Adaptors used on most domestic and imported cars and light trucks including late models
- Supplied with two gauges:
  - High Pressure Gauge - Calibrated from **0 - 300 PSI, (0 - 21.0 kg/sq.cm)**
  - Low Pressure Gauge - Calibrated from **0 - 100 PSI, (0 - 7.0 kg/sq.cm)**
- Use high pressure gauge for all applications
- Use low pressure gauge for more accurate reading of engine oil pressure where maximum oil pressure does not exceed 100 PSI (7.0 kg/sq.cm)
- Comes in a durable vinyl pouch
- Full instructions provided
- **Note:** Do not use low pressure gauge to test automatic transmission pressure

### Replacement Parts:

- **H1734X** gauge head (H1730, H1731, H3041)
- **H3041B** gauge head 100 PSI
- **H3041C** hose assembly (6' oil proof hose)
- **H3041D** 11 piece adaptor kit
  - 1 ea. Bushing, 3/8" NPT Male (GSI #6714)
  - 1 ea. Bushing, 1/4" NPT Male (GSI #6715)
  - 2 ea. 90 degree elbow 1/8" M to F (GSI #6716)
  - 1 ea. 1/8" M to 1/4" M adapter (GSI #6717)
  - 1 ea. 1/8" F to 1/8" F Coupling (GSI #6718)
  - 1 ea. 2" extension, 1/8" M to 1/8" M (GSI #6719)
  - 1 ea. 10mm adapter (GSI #6720)
  - 1 ea. 1/8" BSP adapter (GSI #6721)
  - 2 ea. 8mm adapter (GSI #6722)



## Compression Tester for Diesel Engines

H1845

- For most diesel trucks and cars
- Supplied with three popular adaptor numbers **H1845D, H1845E and H1845J**
- Easy-to-read 2-1/2" diameter gauge head
- Flex hose with swivel head eliminates the need to remove auxiliary equipment such as power brakes and steering, air conditioning and manifold
- Quick side release valve to reset gauge without removal of adaptor
- Gauge Range: **0 - 1,000 PSI, 0 - 70 kg/cm<sup>2</sup>**

### Adaptors Available:

- Listed by vehicle make
- See illustrations

### Replacement Parts:

- **H1845A** Hose Assembly 24-1/4"
- **H1845B** Gauge Head
- **H1845C** Quick Coupler
- **H1845G** Valve Core



### Accessories - Adaptors - Replacement Parts - H1845 Diesel Tester

Manufacturer	Engine	Type	Thread (in)	Adaptor
Allis Chalmers	6000, 7000, 10,000, 11,000	Injector		H1845P
Allix		Injector		H1845P
Audi	All	Injector	24 x 2.0	H1845E*
Audi	1.5, 1.6, 2.0, 2.6 LITRE	Glow Plug	12 x 1.25	H1845H
BedFord™	200, 220, 300, 330, 466	Injector		H1845P
BMW	2.4L	Glow Plug	12 x 1.25	H1845H
Case		Injector		H1845P
Caterpillar	3208, 110 Pencil Type	Injector		H1845FF
Caterpillar	D336, 1674, 1676,	Injector	7/8 x 14	H1845GG
Caterpillar	3406, 3408, 3412	Injector	7/8 x 14	H1845GG
Continental	W/Volvo Engines	Glow Plug	10 x 1.25	H1845M
Cummins	V-185, V-210, V225	Injector		H1845Q
Cummins	V-555, VT-255, VT-555	Injector		H1845Q
Cummins	H, HR, NH, NVH, V6, V8,	Injector		H1845Q
Cummins	V12, All 5.5 Bore	Injector		H1845Q
Cummins	NH and 903 V8 Cylindrical PTB	Injector		H1845Q
Cummins / Case "B"	2.9L, 3.9L, 5.9L	Injector	24 x 1.5	H1845Y
Cummins / Case "C"	8.3L	Injector		H1845DD
Datsun		Injector	24 x 2.0	H1845N
Detroit Diesel	53, 71, 92, 110, 149, V53, V71	Injector		H1845R
Dodge / Cummins	5.9L	Injector	24 x 1.5	H1845Y
Dodge / Cummins	Late model 5.9L ISB & QSB 24 valve	Injector		H1845-3
Flat Allis	8035-02-300, 8035-02-301	Injector		H1845P
Flat Allis	8035-02-302, 8045-02, 8045-03	Injector		H1845P
Ford™	2.0L	Glow Plug	10 x 1.25	H1845M
Ford™ / Escort		Glow Plug	10 x 1.25	H1845M
Ford™ / Lynx		Glow Plug	10 x 1.25	H1845M
Ford™ / Mazda	2.0L	Glow Plug	10 x 1.25	H1845M
Ford™ / Navistar	6.9, 7.3L	Glow Plug	10 x 1.0	H1845D*
Ford™ / Navistar	7.3L Turbo Diesel	Glow Plug	10 x 1.0	H1845KK
Ford™ / Navistar	7.3L Turbo Diesel	Glow Plug	10 x 1.0	H1845-2
Ford™ / Powerstroke	6.0L, 6.4L	Glow Plug	14 x 1.25	H1845-4
Ford™ Ranger	2.2L	Glow Plug	10 x 1.25	H1845M
Ford™ Tempo		Glow Plug	10 x 1.25	H1845M
Ford™ Topaz		Glow Plug	10 x 1.25	H1845M
Ford™ Toyo Kogyo	2.2L	Glow Plug	10 x 1.25	H1845L
Ford™ Tractors	21mm Bosch	Injector		H1845P
Ford™ / Mazda	2.0L	Glow Plug	10 x 1.25	H1845L
General Motors	4.3L V6 & V8, 5.7L V8	Glow Plug	10 x 1.0	H1845D*
General Motors	6.2L & 6.5L V8 True Diesel	Glow Plug	10 x 1.0	H1845J*
GMC Truck	W4, W7, W7HV	Glow Plug	12 x 1.25	H1845H
GMC Truck	6.6L	Glow Plug	10 x 1.25	H1845K
Hino	Medium	Glow Plug	12 x 1.25	H1845H
Int'l Harvester	6.9 L	Glow Plug	10 x 1.0	H1845D*
Int'l Harvester	D/DT361, D/DT429, DV462	Injector		H1845P
Int'l Harvester	DV/DVT550, DT/DV/DVT573	Injector		H1845P
Int'l Harvester	361, 407	Injector		H1845P
Isuzu Chevette	1.8L	Glow Plug	10 x 1.25	H1845K
Isuzu GM	1.8L, 2.2L	Glow Plug	10 x 1.25	H1845K
Isuzu/Luv	2.2L	Glow Plug	10 x 1.25	H1845K
Isuzu Truck	NPR, KS	Glow Plug	12 x 1.25	H1845H
J.I. Case	All Models Except Pencil Type	Injector		H1845P
J.I. Case	188, 207, CID, Pencil Nozzle	Injector		H1845FF



# COMPRESSION & PRESSURE TESTERS



Manufacturer	Engine	Type	Thread (in)	Adaptor
John Deere	Early 300, 400, 500 276	Injector		H1845FF
John Deere	Early 404, 532 CID	Injector		H1845FF
John Deere	404, 466, 531, 619	Injector		H1845P
Kubota	Some models	Glow Plug	10 x 1.25	H1845M
Kubota	Some models	Glow Plug	8 x 1.0	H1845-5
Land Rover		Glow Plug	14 x 1.25	H1845V
Lealand British		Glow Plug	14 x 1.25	H1845V
Lincoln, Mark VII	2.4L 1984 & 1985 cars	Glow Plug	12 x 1.25	H1845H
Mack Truck		Injector		H1845P
Mack Truck	END 405, 457, 475, 510, 519	Injector		H1845P
Mack Truck	605, 672, 673, 674, 711, 864	Injector		H1845P
Mack Truck	END T673, 675, 676, 865, 866	Injector		H1845P
Massey Ferguson		Injector		H1845P
Massey Ferguson	4.203, 4.236, 4.248, 6.354, 8.540	Injector		H1845P
Mercedes	All with 24mm	Injector	24 x 2.0	H1845E*
Mercedes	All with 12mm	Glow Plug	12 x 1.25	H1845H
Mercedes	All with 18mm	Glow Plug	18 x 1.5	H1845F
Mercedes	All with 22mm	Injector	22 x 1.5	H1845HH
Mitsubishi	2 & 3 cylinder engines	Glow Plug	10 x 1.25	H1845M
Mitsubishi-Fuso	Medium	Glow Plug	10 x 1.25	H1845M
Mitsubishi-Fuso	Medium	Injector		H1845P
Navistar	DT360, DT466, 9.0L	Injector		H1845EE
Navistar	312, 360, 414, 436, and 466 C.I.D.	Injector		H1845EE
Navistar	6.9L, 7.3L	Glow Plug	10 x 1.0	H1845D*
Nissan	2.2L	Glow Plug	10 x 1.25	H1845M
Onan	DSL, MDSL	Injector		H1845P
Opel		Injector	22 x 1.5	H1845X
Peugeot	All 2.0 & 2.3L	Glow Plug	12 x 1.25	H1845H
Peugeot		Glow Plug	18 x 1.5	H1845F
Renault		Injector	24 x 2.0	H1845W
Renault		Injector	22 x 1.5	H1845X
Scania	DN11 & DS11	Injector		H1845P
Toyo Kogyo	2.2L	Glow Plug	10 x 1.25	H1845M
Toyota	1.8L	Glow Plug	10 x 1.25	H1845K
Toyota	2.2L	Glow Plug	10 x 1.25	H1845M
UD-Nissan Truck	Medium	Glow Plug	10 x 1.25	H1845M
Volvo	All	Injector	24 x 2.0	H1845E*
Volvo		Glow Plug	12 x 1.25	H1845H
VW	All	Injector	24 x 2.0	H1845E
VW		Glow Plug	10 x 1.0	H1845Z
VW		Glow Plug	12 x 1.25	H1845H
Waukesha	All	Injector		H1845P
White Farm	66, 77, 88, 99, 166, 177, 188, 199	Injector		H1845P
White Farm	550, 660, 770, 880, 950, 1550	Injector		H1845P
White Farm	1555, 1600, 1650, 1655, 1750	Injector		H1845P
White Farm	1755, 1800, D2000, 2300, 3000	Injector		H1845P
Wisconsin	340, 350, 430, 660, 670, 750	Injector		H1845P
Wisconsin	860, 1000	Injector		H1845P



For Applications not Listed Above: H1845S - 1/8" N.P.T. Male Quick Coupler.

This adaptor along with 1- H1845G Valve Core (thread size 12-36) can be used to make your required adaptor for engines not listed above. Remove internal mechanism from an old injector or glow plug from that engine, drill and tap to accept the quick coupler and valve core.

Included in Kit\*



## PISTON RING TOOLS

### Piston Ring Compressor Kit - Ring-O-Matic Series H1670



- Quick change design speeds piston ring installation and increases production
- The Ring-O-Matic pliers and bands are designed to operate in all positions, not just vertically or horizontally
- Pliers incorporates precision locking action for exact holding and quick release

**Kit Includes:**

- **H1670A** Ring-O-Matic Pliers
- **H1670B** for Pistons **2-7/8" - 3-1/8"**
- **H1670C** for Pistons **3-1/8" - 3-3/8"**
- **H1670D** for Pistons **3-3/8" - 3-5/8"**
- **H1670E** for Pistons **3-5/8" - 3-7/8"**
- **H1670F** for Pistons **3-7/8" - 4-1/8"**
- **H1670G** for Pistons **4-1/8" - 4-3/8"**

**Larger bands available:**

- **H1670H** for Pistons **4-1/2" - 4-3/4"**
- **H1670I** for Pistons **4-3/4" - 5"**
- **H1670J** for Pistons **5" - 5-1/4"**
- **H1670K** for Pistons **5-1/4" - 5-1/2"**
- **H1670L** for Pistons **5-1/2" - 5-3/4"**
- **H1670M** for Pistons **5-3/4" - 6"**



## TUNE-UP TOOLS

### Mechanic's Stethoscope H1262

- This sensitive instrument provides a fast and accurate method of locating problem in engines and other moving parts
- Earphones block outside noises
- Plastic handle protects user from shock

## Head & Valve Repair

### VALVE SPRING COMPRESSORS

#### Deluxe Overhead Valve Spring Compressor

**H3456**

- Designed to service most cars with overhead valves and newer vehicles with confined areas under the hood
- The knob is removable exposing a 5/8" hex post allowing the technician to operate the tool with a 5/8" wrench or socket
- The components are heat treated for added strength and long service life
- Not to be used with impact tools. Use on or off the car



#### Valve Spring Compressor

**H3183**

- Vertical lift design
- Equipped for 1" - 2" spring diameters. Height: 10" Width: 8"
- Prevents bending of valve stem. Sure, one hand control lock and release is powerful enough to compress the strongest spring with ease
- Quickly adjusts for any valve stem length. One simple adjustment with the pin-operated screw on the first set of valves sets clamp for the balance of springs.
- Replacement Jaws (included with tool): **H3183A** Straight Jaw (pair), **H3183B** Offset Jaw (pair)
- Optional Jaws: **H3183C** Extra High Offset Jaw

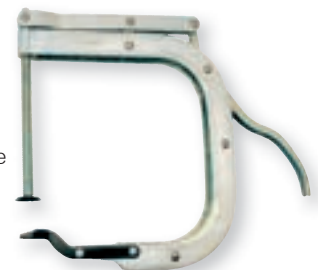



## Rubber Cup Valve Lapping Sticks

- For precision hand grinding valves and seats
- Synthetic rubber cup is resistant to oil, gasoline and grinding compounds
- Comfortable wooden handle. A must for that final valve to seat fitting operation

PROD. NO.	Cup
<b>H1183</b>	3/4"
<b>H1185</b>	1-3/16" and 1-5/16"



H1183



H1185

## TUNE-UP TOOLS

### Ignition Point & Machine File

**H1866**

- Double cut ignition files made from high quality steel with Rockwell Hardness of 65
- Easily cuts tungsten or platinum contact points
- Use on ignition points, spark plugs, relays, circuit breakers and much more
- 2 per package



### In-Line Ignition Spark Tester

**H3143**

- Connects in-line between spark plug and spark plug wire
- Shows a duplicate view of the ignition spark
- Technician can visually check condition of each cylinder
- Frequency and intensity of flash pattern indicates whether there is an ignition or fuel delivery system problem. Flash can be seen in bright sunlight
- Clear plastic body can withstand rough use and resists automotive chemicals
- Flexible wire protected by mechanical strain relief
- Instructions included



### Spark Plug Boot Pliers - Angled Jaws

**H3295**

- Designed to protect against plug wire and boot separation.
- Handle and jaws are vinyl coated to insure complete insulation and non slip grip
- Overall length: **9-3/4"**





## Exhaust System

H1017 / H1175

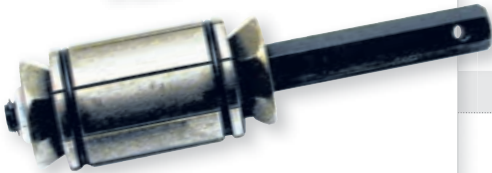

H1176

## MUFFLER EXPANDERS

- Use with impact wrench
- Removes clamp grooves and rounds out exhaust pipes
- A practical, rugged tool that makes easy work of a tough job
- Expansion rings set in deep grooves to prevent wear

**⚠ CAUTION:** Not to be used to stretch pipe.

### Pipe & Muffler Expander - Standard

**H1017**

for Passenger Cars

### Pipe & Muffler Expander - Small

**H1175**

for Compacts & Foreign Cars

### Pipe & Muffler Expander - Extra Large

**H1176**

for Passenger Cars & Trucks

## PRESSURE TESTERS

- Unique design allows pressure to be taken either through the oxygen sensor hole or through the exhaust pipe with a threaded insert system (included)
- Accurately determines excessive exhaust back pressure caused by catalytic converter or muffler blockage

### Exhaust Pressure Tester

**H3148**

#### Kit Includes:

- **H3148A** Gauge: 0 - 15 lbs
- **H3148B** Hose Assembly
- **H3148C** Insert Installing Tool
- **H3148D** Oxygen Sensor adaptor 18mm
- **H3148E** Oxygen Sensor adaptor 12mm
- **H3148F** 10 Pack
- Inserts, Washers, Screws



**6 PC Disconnect Tool Set H3501**

- Easily disconnect spring lock couplings on Ford® and Chrysler® air conditioning lines
- Use on fuel line quick connect couplings found on late model GM®, Ford® and Chrysler® can be used on Ford® transmission and radiator cooler lines
- Set contains six colour coded tools that are stamped with size for quick identification
- Sizes: S.A.E. **5/16", 3/8", 1/2", 5/8", 3/4", 7/8"**  
Metric **8, 9, 13, 16, 19, 22mm**



**11 PC Master Disconnect Tool Set H3544**

- This master fuel line quick disconnect tool set broadens the applications of disconnecting fittings and spring lock couplings on fuel, filter cooler and transmission oil lines
- Fuel line disconnects are colour coded anodized aluminum for easy identification
- A must for all mechanical service shops
- Use with most vehicles on the market today
- Comes in convenient blow mould storage case



**Disconnect Tool for Fuel and Air Conditioning Lines H3089**

- This spring-lock coupling release tool easily separates fittings on fuel and air conditioning lines
- Sizes: **3/8", 1/2", 5/8"** and **3/4"**



**Disconnect Tool for Fuel Lines H3351**

- This spring-lock coupling release tool easily separates fittings on fuel lines
- Sizes: **3/8"** and **5/16"**



**Disconnect Tool for GM® Heater Lines H3364**

- Releases heater line quick connect fitting from engine block and thermostat housing
- 1991 - current GM® 3.1L / 3.4L and 3800 engines





## FLUID LINE TOOLS

### Disconnect Tool for Ford® Fuel Lines **H3352**

- 1990 - current Ford® Ranger® and Explorer with 4.0 Litre, 6 cylinder engines



### 2 PC Disconnect Tool Kit for Fuel, Transmission and Oil Cooler Lines **H3354**

- Separates quick connect fittings from transmission, radiator oil cooler and power steering lines

**Kit Includes:**

- Ford®/GM® quick disconnect coupler tool and Ford® oil cooler line disconnect tool

**Applications:**

- Ford® EFI fuel lines with hair pin connectors
- Transmission/oil cooler lines on 1989 - current/GM® 1/2, 3/4 and 1 Ton pickups; 1986 - current Ford® Taurus and Mercury Sable with AXOD, AOD, or ATX transmissions



### 1/4" Disconnect Tool for Fuel Lines **H3356**

- 1995 - 1996 Ford® Mustang 1/4" fuel pump return line



### 5/16" Disconnect Tool for Fuel Lines **H3357**

- 1990 - current Ford® Aerostar, Explorer, Bronco® with 5/16" fuel lines
- 1991 - current Ford® E and F series trucks with 5/16" fuel lines
- 1992 - current Ford® Ranger® with 5/16" fuel lines
- 1992 - current GM® with 5/16" fuel lines



### Disconnect Tool for Ford® / GM® CFI Fuel Lines **H3353**

- Ford® CFI fuel lines with hair pin connectors
- Universal for radiator to transmission oil cooler lines
- 1987 and later model Olds Tornado; Buick Riviere® and Reatta®; Cadillac Eldorado®, Seville® and Concours®; 1989 and later Model GM® 1/2, 3/4 and 1 Ton pickups



### Disconnect Tool for Ford® Oil Cooler Lines **H3355**

- Ford® vehicles with AXOD, AOD, or ATX transmission



### 3/8" Disconnect Tool for Fuel Lines **H3358**

- 1990 - current Ford® Aerostar, Explorer, Bronco® with 3/8" fuel lines
- 1991 - current Ford® E and F series trucks with 3/8" fuel lines
- 1992 - current Ford® Ranger® with 3/8" fuel lines
- 1994 - 1997 Dodge® Ram V6 and V8 trucks with 3/8" cooler lines
- 1995 - 1996 Dodge® Ram Van/Wagon with 3/8" cooler lines



### Disconnect Tool for Ford® Oil Cooler Lines **H3359**

- Ford Taurus® and Escort® oil cooler lines on AXOD and ATX transmission



Caution: release system pressure before using these tools!

## 40 PC Master Fuel Injection Test Kit

H2000

- Contains all items necessary for checking the fuel injection systems on most domestic and foreign vehicles
- Features a large, **3-1/2" gauge** head with dual readings of **0 - 145 PSI** and **0 - 1,000 kPa**, and **2-1/2" gauge** with dual readings of **0 - 15 PSI** and **0 - 100 kPa**
- All adaptors, gauge heads, and hose assemblies feature a quick coupling system
- Comes complete with instructions in a blow moulded carrying case
- Case will accommodate H2000UPA Supplement Kit

### Parts and Accessories for Test Kits H2000/H2002

#### Gauges and Hoses

<b>H2000A</b>	3-1/2" Gauge Head with dual readings 0-145 PSI and 0-1000 KPA (10 Bar) Can be used for all tests
<b>H2000AA</b>	Low pressure 2-1/2" Gauge with dual readings 0-15 PSI and 0-1kg/cm <sup>2</sup> (1 Bar) Use for tests where an accurate reading below 15 PSI is required
<b>H2000AB</b>	Quick Coupler
<b>H2000D</b>	Gauge Hose Assembly with blow-down valve
<b>H2000G</b>	CIS/TBI Test Hose
<b>H2000DX</b>	72" Extension Hose
<b>H2000RK</b>	Repair Kit, O-Rings, Washers

#### Test Port Adaptors

<b>H2000B</b>	Large Schrader Type Test Hose with 7/16" x 20 thread
<b>H2000BK</b>	Replacement Washer and Pin for H2000B
<b>H2000B90</b>	Large Schrader 90° Adaptor
<b>H2000C</b>	Small Schrader Type Test Hose with .308 x 32 thread
<b>H2000C90</b>	Small Schrader 90° Adaptor

#### In-Line Testing TBI

<b>H2000S</b>	Union 5/8" x 18
<b>H2000T</b>	16mm x 1.5 Female Tube Nut (2)
<b>H2000U</b>	16mm x 1.5 Male Tube Nut (2)
<b>H2000UA</b>	14mm x 1.5 Female Tube Nut (2)
<b>H2000UB</b>	14mm x 1.5 Male Tube Nut (2)
<b>H2000UC</b>	14mm x 1.5 Plug
<b>H2000UPA</b>	

#### In-Line Testing - Special Connections

<b>H2000F</b>	Double-ended Hose Fitting 5/16" - 3/8"
<b>H2000W</b>	Spring Lock Hose - Common Application Ford® CFI
<b>H2000X</b>	Hair Pin Hose 5/16" - Common Application Ford® EFI
<b>H2000XA</b>	Hair Pin Hose 3/8" - Common Application GM®, Chrysler®



#### End of Line, Banjo - Fuel Bolt Adaptors

<b>H2000E</b>	Single End Hose Connection - 1/4" x 3/8"
<b>H2000N</b>	6mm x 1.0 Thread
<b>H2000NN</b>	8mm x 1.0 Thread
<b>H2000P</b>	10mm x 1.0 Thread
<b>H2000Q</b>	12mm x 1.25 Thread
<b>H2000R</b>	12mm x 1.5 Thread
<b>H2000RA</b>	14mm x 1.5 Thread

#### In-Line Testing CIS, CISE and K-Jetronic

<b>H2000H</b>	8mm x 1.0 Male Long
<b>H2000HA</b>	8mm x 1.0 Female Long
<b>H2000HH</b>	10mm x 1.0 Male
<b>H2000J</b>	8mm x 1.0 Female
<b>H2000K</b>	12mm x 1.5 Swivel Female (2)
<b>H2000KA</b>	14mm x 1.5 Swivel M and F
<b>H2000KB</b>	16mm x 1.5 Swivel M and F
<b>H2000KC</b>	1/4 BSPT Swivel M and F
<b>H2000L</b>	10mm x 1.0 Female
<b>H2000M</b>	8mm x 1.0 Male (2)

#### Adaptors for Chrysler® and Mitsubishi®

<b>H2000M11</b>	11mm
<b>H2000M15</b>	15mm
<b>H2000M16</b>	16mm

## Multi-Port Injection Pressure Tester

H2002

- Test fuel pump pressure on most domestic and import vehicles equipped with multi-port fuel injection systems using the small or large Schrader type connection
- Can be used on most import vehicles, except those equipped with Bosch C.I.S
- Includes bleed-off valve with hose to safely enable technician to depressurize fuel system after testing
- **3-1/2" gauge** diameter has dual scale: **145 PSI/1,000 kPa**
- Full instructions included
- Supplied in vinyl storage pouch





## OPEN STOCK SOCKETS

### 7/8" with Cut-Away Oxygen / Vacuum Sensor Socket

H3327

- Removes and installs oxygen sensors and vacuum switches on computerized engine control vehicles
- 3/8" drive x 7/8" hex socket with cut-away slot** provides extra clearance for oxygen sensor wires during use



### 7/8" 6 Point Oxygen Sensor Offset Socket Wrench

H3586

- Removes and installs oxygen sensors on vehicles with computerized engine control
- Offset design for increased maneuverability
- 7/8" 6 point socket** with cut-away slot provides extra clearance for oxygen sensor wires during use



### 29mm Narrow Slot Oxygen / Vacuum Sensor Socket

H3580

- 1/2" drive, 29mm narrow slot** oxygen sensor socket



### 27mm Injector Socket

H3595

- 1/2" drive, 27mm x 3-1/4"**
- With window



### 1-1/16" Oil Pressure Sending Unit Socket

H3440

- Remove and install **1-1/16" oil pressure sending units up to 2-5/8" long**
- Heat treated alloy steel
- Use with **3/8" square drive or 1-1/8" hex wrench**
- Fits most 1991 to current GM® vehicles using oil pressure gauge and 1987 to current Chrysler® with light and gauge



### Oxygen Sensor Offset Socket Wrench

H3346

- Removes and installs oxygen sensors on vehicles with computerized engine control
- Offset design for increased maneuverability
- Features a **7/8" hex and 1/2" double square drive with cut-away slot** providing extra clearance for oxygen sensor wires during use



### 7/8" Narrow Slot Oxygen / Vacuum Sensor Socket

H3583

- 3/8" drive x 7/8"**



**Spray Cleaning Gun Kit** **H3192**

- High speed 2-way action quickly blasts dirt, grease and oil
- Sprays cleaning solvents under high pressure. Will also blow air only
- Pressure trigger for maximum efficiency
- Includes 4 ft siphon hose with screen
- Operates with one HP or larger air compressor delivering 3.0 CFM at 60 PSI
- Air inlet: 1/4" NPT



## PULLERS & PULLER KITS

**Power Steering Pump & Alternator Pulley Tool** **H3341**

- 2-in-1 tool removes and installs pulleys
- Features a two sided flange which fits all domestic automobiles including GM®, Chrysler® and Ford®
- Remove and install Saginaw®, Thompson® and Ford® C-2 power steering pumps with grooved assemblies
- Works on alternator pulleys with the following grooved hub diameters:

**S.A.E. 1-1/8, 1-1/4, 1-5/16, 1-3/8"**

**Metric 28, 32, 34, 35mm**

**⚠ CAUTION:** Do not use with impact tool!



**6 PC Power Steering Pump Pulley KIT** **H3565**

- Remove and install power steering pump pulleys without damage
- Use on most Chrysler®, Ford® and GM® vehicles
- Comes with two screw shafts for various pump sizes
- Fits pulley hub diameters of: **1-1/8, 1-1/4, 1-5/16, 1-3/8"**
- Comes in convenient blow mould storage case

**Applications:**

- 1988 - to current GM® Quad 4 engines
- 1989 - to current GM® 1/2", 3/4", and 1 ton pickups
- 1990 - to current Chevrolet Lumina® APV, Pontiac TransSport®, Oldsmobile Silhouette®
- 1991 - to current (3.1L V6 engines) Chevrolet Lumina® sedan, Olds Cutlass Supreme®, Buick Regal®, Pontiac Grand Prix®
- 1991 - to current Ford® (4.6L engines)
- The included H3353 disconnect tool disconnects the fuel line on most 1987 - to current Cadillac®, Oldsmobile®, and Buick® vehicles



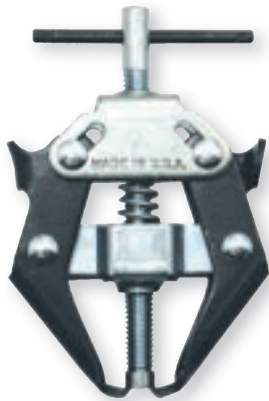

## PULLERS & PULLER KITS

### Power Steering Pump Pulley Set

**H3566**

- Remove and install alternator and power steering pulleys on late model Chrysler®, Ford® and GM® engines
- Reverse the jaws to pull the alternator internal bearings
- Will not damage pump or pulley
- Comes in convenient blow mould storage case

#### Applications:

- 1988 - to current GM® Quad 4 engines
- 1990 - to current Chevrolet Lumina® APV, Pontiac TransSport®, Oldsmobile Silhouette®
- 1991 - to current (3.1L V6 engines) Chevrolet Lumina® sedan, Olds Cutlass Supreme®, Buick Regal®, Pontiac Grand Prix®
- 1991 - to current Ford® (4.6L engines)

#### Kit Includes:

- Pulley Body, Centre Bolt, 2 Piece Jaws with Retaining Ring, Bearing, Washer and small Button
- Puller Pins for Quad 4, GM® 3.1L
- Installing Screws for Quad 4, GM® 3.1L, Ford® 4.6L and others



### 1-1/4" Gear and Bearing Puller

**H1905**

- Unique spring action that permits a one handed operation
- Forces the jaws tighter as more pressure is applied to the pressure screw
- Pressure screw has a protector on the end to prevent damage to the object pulled
- The **1-1/4" capacity** is ideal for small bearing, battery terminals and other small pulling jobs
- All parts are plated for rust and corrosion protection

### 5 PC Internal and External Bearing Puller Kit

**H3562**

- Remove internal and external bearing cups, seals, bushings etc
- Special cone adaptor included which securely locks jaws on part to be removed
- Use with slide hammer for more torque
- Comes in convenient blow mould storage case

#### Kit Includes:

- **2.7lb** (1.24kg) Slide Hammer (5/8"-18 thread)
- Two Internal 3 Jaw Kits (Capacity 10 - 30mm, 30 - 80mm)
- External 3 Jaw Kit (10 - 80mm)
- Cone adaptor





## Steering Wheel Puller H1903

- For all major makes of automobiles: 5/8" x 4" centre screw has recessed floating swivel
- Five Sets of (2 each) side screws: 3/8" - 16 x 4", 5/16" - 18 x 4-1/2", 5/16" - 24 x 3-1/2", 1/4" - 28 x 3", M8 x 1.25 x 80mm



## Harmonic Balancer Puller Kit H1901

- Designed to pull balancers, vibration dampers, pulleys, or any tool with tapped holes. Two or three hole applications
- Floating swivel prevents damage to shaft ends
- Range: **1-3/8" - 3-9/16"**
- 5 sets of side screws provided



## Pilot Bearing Slide Hammer Puller H1921

- Slide hammer type
- Use to remove sleeve type bearings from 1/2" - 1-1/2" inside diameter on flywheels, pumps, and generators
- Turn the handle for quick adjustment and the centre rod spreads the alloy steel jaws for a tight fit inside the bearings
- A few light taps with the sliding hammer, and the bearing is removed

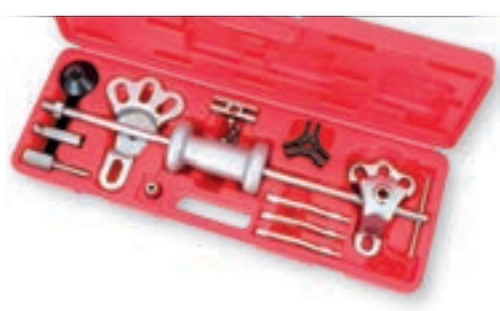

## Slide Hammer Multi-Purpose Puller Set - Heavy Duty H3560

- Extract flange-type rear axles, semi-floating rear axles bearings, balancers and other press-on parts
- With the 2/3 jaw combination, it can remove gears, outer races, grease retainers, oil seals and other internal/ external pulling jobs
- Use on most cars and light trucks that have axles with bolts and studs no larger than 9/16" in diameter
- Applies to 4.5 and 6 bolt stud circles that range from **4-1/4" - 5-9/16"**
- Slide hammer is: **5 lbs (2.32kg)**
- Comes in convenient blow mould storage case



## GEAR PULLERS



### 2 or 3 Jaw Combination Gear Pullers

- Assemble with 3 jaws for maximum stability, or with 2 jaws where access is limited – 2 pullers in 1
- Jaws, yokes and forcing screw made of heat treated Chrome Vanadium steel for ultimate strength
- Reversible jaw design allows internal and external pulling
- Jaws grip tighter as pulling force increases
- All components hardened to HRC 42~45 for professional use
- Fine-threaded 440 CrV forcing screw allows precise control for damage free pulling
- Can be used with bearing separators

PROD. NO.	MOD. NO.	Reach	Spread	Capacity	Screw Length	Pitch	Jaw Thickness	Jaw Width
770132	JGP-3HD	3-1/4"	4-3/4"	2 tons	4.9"	3/8"-24 tpi	1/8, 1/4"	1/4, 7/16"
770133	JGP-4HD	3-1/2"	7"	5 tons	7"	9/16"-20 tpi	1/4, 5/16"	3/8, 3/4"
770134	JGP-6HD	5-1/2"	7"	5 tons	7"	9/16"-20 tpi	1/4, 5/16"	3/8, 3/4"
770135	JGP-8HD	5-1/2"	9-1/2"	5 tons	9"	11/16"-18 tpi	5/16, 11/32"	7/8"

## BEARING SEPARATORS - HEAVY DUTY

- Separator bodies made of heat treated Chrome Vanadium steel for maximum strength
- All components hardened to HRC 42~45 for professional use
- Separators have knife like edges to get behind bearings where regular gear puller jaws are too thick to grip
- Can be used with push or pull type gear pullers



### 12 PC Bearing Separator Set

**770302 / JBS-12**

- Includes components to assemble push-type puller

Maximum Reach	Capacity	Forcing Screw	Hole Size
3"	5 tons	7", 9/16" x 10 tpi	3/8" x 16 tpi

**Contents:** 2-1/4" Bearing Separator (1), 3-1/2" Bearing Separator (1), Yoke (1), Forcing Screw (1), Main Rods (4), Extension Rods (4)



### Open Stock

PROD. NO.	MOD. NO.	Capacity	Hole Size
770312	JBS-225	1-3/16" – 2-1/4"	3/8" x 16 tpi
770313	JBS-350	2-1/4" – 3-1/2"	3/8" x 16 tpi
770314	JBS-450	3" – 4-1/2"	1/2" x 16 tpi

## 22 PC Hydraulic Gear Puller Kit

770152 / JHGP-10S

- Jaws, yokes, bearing separator and ram made of heat treated Chrome Vanadium steel for ultimate strength
- Hydraulic ram requires no power - develops up to **10 tons of pressure** with hand power only
- All components hardened to HRC 42~45 for professional use
- Includes twin and triple heads for assembling 2 jaw and 3 jaw pullers
- Includes 4-1/2" bearing separator
- Comes in convenient blow mould storage case

Reach	Spread	Capacity	Pieces (total)
4"	10"	10 tons	22

### Contents:

Hydraulic Ram (1), 4" Puller Legs (3), 6" Puller Legs (3), 8" Puller Legs (3), Collar (1), Twin Head (1) Triple Head (1), End Cap (1), 2" Ram Extension (1), Yoke (1), 4-1/2" Bearing Separator (1), Main Rods (2), Extension Rods (2)



# HAND BRUSHES

## Parts Cleaning Brush

H1039

- Chemical resistant bristles are crimped to hold more fluid for faster cleaning
- The bristles are tapered to get into tight places
- Plastic handle



H1039

GEAR PULLERS  
See pages 228-229 Pullers section  
for similar products

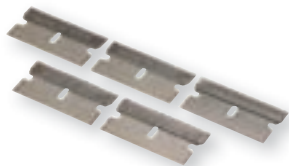

H3237DA



## SCRAPERS

### Razor Blade Scraper - Folding Arm Style

H1363

- All purpose use scraper. Locks in three positions.
- Handy to remove inspection stickers, paint, masking tape and general scraping jobs.
- Rugged steel construction.
- One steel blade included.

### Razor Blades - Single Edge (100/Pack)

H1363C

- 100 per box
- Steel blades fit all single edge blade holders

### Razor Blade Scraper - Extended Arm Style

H1364

- All purpose scraper
- Designed for hard-to-reach areas to remove inspection stickers, paint, masking tape and general purpose scraping
- Ergonomic handle with steel shaft
- One steel blade included
- Overall length: **12-1/2"**
- Replacement blade: H1363C (box of 100)

### Razor Blade Scraper - Stubby Pocket Style (30 PC)

H3237DA

- Sturdy scraper for home, auto or shop
- Compact pocket size
- Removes stickers, labels, paint etc
- Colourful easy grip cushioned handle
- Uses standard single edge razor blades (see above).
- H3237DA Cookie Jar Counter Display Assortment
- Contains 30 – mini scrapers in 5 assorted coloured handles
- Cookie jar is non-breakable plastic with snap shut lid

## SEAL PULLER

### Seal Puller

H3052

- Easily removes oil and grease seals on automobiles and light trucks.
- Two different tips reach in and fit most seals.

**5 Blade Non-Magnetic Feeler Gauge** **H1137**

- Blades made of non-magnetic brass and will not affect the electronic components of the distributor
- Five blades cover the sizes needed
- Metric equivalents marked on blade
- Blade Thickness: **.006 .008 .010 .012 .014 .016**



**25 Blade Universal Master Gauge** **H1859**

- Metric equivalents marked on blades
- .0015 plus .002 to .035 in .001 increments
- Blade Size: 3-1/16" x 1/2"
- Blade Thickness: **.0015, .002, .003, .004, .005, .006, .007, .008, .009, .010, .011, .012, .013, .014, .015, .016, .018, .020, .022, .024, .025, .028, .030, .032, .035**



**21 Blade Extra Length Offset Style Feeler Gauge** **H1863**

- Blade Sizes: 4" x 1/2", 1"-45° offset
- Blade Thickness: **.006 .007 .008 .009 .010 .011 .012 .013 .014 .015 .016 .017 .018 .019 .020 .021 .022 .023 .024 .025 .026**

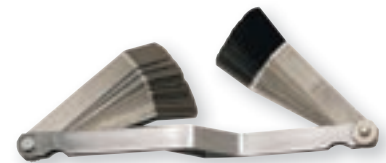

**22 Blade Go, No-Go Style Feeler Gauge** **H3105**

- Blade Sizes: 3" x 1/2" Step Ground
- Blade Thickness: **.004-.006 .005-.007 .006-.008 .007-.009 .008-.010 .009-.011 .010-.012 .011-.013 .012-.014 .013-.015 .014-.016 .015-.017 .016-.018 .017-.019 .018-.020 .019-.021 .020-.022 .021-.023 .022-.024 .023-.025 .024-.026 .025-.027**





## OIL FILTER WRENCHES



### H3370

- Heat-treated steel, black oxide finish to prevent corrosion
- Use with **3/8" square drive** ratchet
- Tough, durable, built to last
- Wrenches are specifically designed for 1 or 2 step models, fitting various flute designs on Fram, AC, Casite, Lee, Hastings, Motorcraft, NAPA, Purolator, STP, Pure One, Wix and some Japanese and European made filters



### 14 PC Cap Style Filter Wrench Set

**H3370**

#### Individual Cap Wrenches:

	Metric Size	Decimal Equivalent	Flutes
H3371	74/76 mm	2.91/3.0"	15 – 2 steps
H3372	76 mm	3.00"	14
H3373	93 mm	3.66"	15
H3374	73 mm	2.875"	14
H3375	65/67 mm	2.56/2.63"	14 – 2 steps
H3376	68 mm	2.68"	14
H3377	80 mm	3.15"	15
H3378	90 mm	3.54"	15
H3379	80/82 mm	3.15/3.23"	15 – 2 steps
H3380	93 mm	3.66"	36
H3381	75/77 mm	2.95/3.03"	15 – 2 steps
H3382	65 mm	2.56"	14
H3383	76 mm	3.00"	30
H3384	100 mm	3.937"	15



### Cap Style Filter Wrench - Dual Size

**H1099**

- For installing or removing oil filters
- Fits most makes and models of filters with fluted ends. Won't damage filter
- Steel / nickel plated uses 3/8" square drive socket wrench or 1" open end wrench to operate
- Dual Size for **2-7/8 - 3"**
- Compact Size Filters - **15 Flutes**

### 14 PC 3/8" DR Oil Drain Plug Socket Set

**H3700**

- Fits oil drain plugs on most domestic, European and Asian vehicles
- Great for oil change professionals
- Bright-finished Chrome Vanadium steel sockets comes on a metal clip rail
- Contains:



H3700-10	3/8" Dr. Oil Drain Plug Socket (8mm Hex)
H3700-11	3/8" Dr. Oil Drain Plug Socket (9mm Hex)
H3700-12	3/8" Dr. Oil Drain Plug Socket (10mm Hex)
H3700-13	3/8" Dr. Oil Drain Plug Socket (12mm Hex)
H3700-14	3/8" Dr. Oil Drain Plug Socket (14mm Hex)
H3700-15	3/8" Dr. Oil Drain Plug Socket (17mm Hex)
H3700-16	3/8" Dr. Oil Drain Plug Socket (10mm Square)
H3700-17	3/8" Dr. Oil Drain Plug Socket (7mm Square)
H3700-18	3/8" Dr. Oil Drain Plug Socket (8mm Square)
H3700-19	3/8" Dr. Oil Drain Plug Socket (11mm Square)
H3700-20	3/8" Dr. Oil Drain Plug Socket (13mm Square)
H3700-21	3/8" Dr. Oil Drain Plug Socket (5/6" Square)
H3700-22	3/8" Dr. Oil Drain Plug Socket (3/8" Square)
H3700-23	3/8" Dr. Oil Drain Plug Socket (10mm Triangle)



### 4 PC Oil Filter Canister Socket Set

**H3702**

- Specially designed low profile **3/8" sq. drive** sockets used for removing oil filter canister cover on vehicles that have limited access
- Cartridge type oil filters are easier to change with these specialty sockets
- When using a conventional socket, the top side of the socket can contact other surrounding components which could cause damage or make it difficult to completely remove the oil canister cover
- Made from Chrome Vanadium Steel (CRV)
- Not for use with impact tools
- Contains:

H3702-10	Oil Filter Canister Socket (24mm)
H3702-11	Oil Filter Canister Socket (27mm)
H3702-12	Oil Filter Canister Socket (32mm)
H3702-13	Oil Filter Canister Socket (36mm)



## Band Type Filter Wrench - Non-Swivel Handle

**H1014**

- Stainless steel band is 7/8" (22.2mm) wide
- Full length ergonomic cushion grip handle for comfort
- All steel handle construction, plated for rust protection
- Studs on inside of band help prevent slipping
- Farm and Fleet
- Range: **4-3/4" - 5-1/8" (120.6 - 130.1mm)**



## Band Type Filter Wrenches - Swivel Handle

- Features a self-locking bolt in the handle instead of a rivet for less wear and tear
- Stainless steel band is 1" (25mm) wide, supported on the outside joint
- Full length ergonomic cushion comfort grip handle for comfort
- All steel handle construction, plated for rust protection
- Studs on inside of band help prevent slipping



	Type	Range
<b>H1060</b>	Small	<b>2-3/8" - 2-7/8" (60.3 - 73mm)</b>
<b>H1061</b>	Compact	<b>2-7/8" - 3-3/8" (73 - 85.7mm)</b>
<b>H1062</b>	Standard	<b>3-3/8" - 3-3/4" (85.7 - 95.2mm)</b>
<b>H1063</b>	Large	<b>3-3/4" - 4-3/8" (95.2 - 111.1mm)</b>

## Band Type Truck Filter Wrenches - Swivel Handle

- Designed for use on Cummins, Detroit Diesel and Caterpillar engines
- Has a self-locking bolt so that wear can be taken up after long use
- Steel bands one full inch wide
- Full length cushion grip handle for comfort
- Studs on inside of band help prevent slipping



	Type	Range
<b>H3433</b>	Cummins & Detroit Diesel Engines	<b>4-5/16" - 4-3/4" (110 - 120mm)</b>
<b>H3434</b>	Caterpillar Engines	<b>5-1/4" - 5-3/4" (134 - 146mm)</b>

## Expandable Filter Wrench

**H3055**

- Removes all passenger car and light duty truck spin on type oil filters
- Serrated legs provide strong gripping power
- Range: 2-3/8" - 4-3/4" (60.3 - 120.7mm)
- Use with 3/8" square drive



H3078



H3055

## 1/2" Square Drive Oil Filter Wrenches - Heavy Duty

Range

<b>H3078</b>	<b>4-1/8" - 4-21/32" (104 - 118mm)</b>
<b>H3079</b>	<b>4-21/32" - 5-5/32" (118 - 131mm)</b>
<b>H3090</b>	<b>5-5/32" - 5-21/32" (131 - 144mm)</b>

## Strap Filter Wrench - Standard

**H1295**

- For installing or removing oil filters
- Adjusts quickly to oil filter. Use with square drive ratchet handle or open-end wrench
- Strap is made of a durable oil resistant nylon web that will not slip
- For cars and trucks: **6" capacity**
- 1/2" square drive or 3/4" open-end wrench



## Heavy Equipment Band/Strap Filter Wrench **H3241**

- Heavy duty cordura strap for high torque requirements
- Tightening and turning device has 3/8" square drive on one end and 1/2" square drive on the other
- Range up to **9" (228mm)** approx.
- Strap length approx. 25"



## Oil Filter Removal Pliers

**H3310**

- For removal and installation of spin-on oil and fuel filters
- Self-adjustable. Spring action slip joint. Gripping jaws and cushion grip handles
- Range: **2-1/4" - 6" (60 - 152 mm)**



**Caution:** Do not use with power or impact tools.



## DRIVER BITS & SOCKETS

### 8 PC 3/8" DR Triple Square Driver Bit Set H1458

- Bit sockets are **3/8" sq. dr.** with a black oxide tip, matte finish and made from SNCM 8660 steel
- For use on triple square fastener bolts typically found on European vehicles (especially German)
- For use on cylinder heads, axle shafts, rear toe adjusters, differentials, transmission drain plugs, clutches, belly pans, brake calipers and more
- Other uses include: Detroit Diesel® flywheel bolts, crank pullers on 900 & 4000 series engine, and headbolts on 900 series
- Bit sockets are NOT designed for use with power impact tools
- **CAUTION:** Triple square bit sockets may strip the head of double hex bit fasteners found on many Asian vehicles



	Socket Size		Socket Size
H1458-10	4mm	H1458-14	10mm
H1458-11	5mm	H1458-15	12mm
H1458-12	6mm	H1458-16	14mm
H1458-13	8mm	H1458-17	16mm

## PUNCHES - BRASS

- Ideal when sparks from a steel punch would be dangerous
- A must for those driving jobs where a soft punch is required

### Tapered Punch (5/8" Hex to 3/8" Point) H3095



### Drift Punch (3/4" Diameter - Knurled Grip) H3096



### 4 PC Triple Square Driver Bit Set

**H1456**

- For use on 12 point fasteners
- Triple square design. Alloy steel
- Made from Chrome Vanadium 6150 - 50 - 54 Rockwell Hardness



	6mm	5/16"	'Hex x 2-1/2" Long
H1452	Drill Size	Type and Length	Belongs to Set
H1453	Drill Size	Type and Length	Belongs to Set
H1454	Drill Size	Type and Length	Belongs to Set
H1455	Drill Size	Type and Length	Belongs to Set

**CrV**

## STUD, BOLT & NUT REMOVAL

### Nut Splitting Tool

**H1858**

- For removal of rusted or corroded nuts. It will **split nuts up to 3/4"** across flats, just a few turns with any 3/4" hand wrench (no power needed)
- Especially handy for front and rear shock absorber stud-end nuts
- Overall length: **4-1/8"**



## PLIERS

### Universal Lock Ring Pliers

**H3056**

- Removes and installs lock rings used on brakes, transmissions, pedal shafts and clutch shafts
- The scored jaws hold rings securely





# SCREWDRIVERS



## 15-in-1 Multi Bit Screwdriver H3400

- Features a patented pullout bit cartridge
- 14 of the most popular bits means one multi-driver replaces 14 screwdrivers and one 1/4" hex nut drive
- 2" double end bits are made of superior quality S2 steel for strength and durability
- Shaft is made of super high strength 12T14 steel for long life
- End of shaft is a 1/4" hex nut driver
- Handle is made of durable nylon reinforced triax resin for longest life.
- Unique rotating cap design allows you to position the cap in the palm of your hand and rotate the driver handle with your fingers. The driver then acts like a gearless ratcheting screwdriver, increasing productivity while reducing blisters and operator fatigue
- Collar also swivels 360° for fast, efficient driving of screws
- Made in the U.S.A.



**Distributors please note: Drivers are sold in 6 pack P.O.P. displays only.**

### REPLACEMENT BITS:

<b>H3400C</b>	PH 1+PH3
<b>H3400D</b>	PH1+PH2
<b>H3400E</b>	S1+S2
<b>H3400K</b>	S0+S3
<b>H3400J</b>	F4+F6
<b>H3400F</b>	T10+T15
<b>H3400G</b>	T20+T25
<b>H3400H</b>	T27+T30



# SCREW EXTRACTORS

## 5 Piece Flute Type Screw Extractor Set H1273

- Five extractors with sharp undercut edges to provide solid grip in studs, set screws, pipe and zerk fitting
- Made from Chrome Molybdenum (50 - 52 Rockwell hardness)



	U.S.S. Screw or Bolt Size	Drill Size	Min. Depth of Hole	Pipe Size
<b>H1273A</b>	1/4", 5/16"	1/8"	3/8"	
<b>H1273B</b>	3/8"	3/16"	1/2"	
<b>H1273C</b>	7/16"	15/64"	1/2"	1/8"
<b>H1273D</b>	1/2", 9/16"	5/16"	1/2"	1/4"
<b>H1273E</b>	5/8"	3/8"	5/8"	3/8"



## 5 Piece Spiral Type Screw Extractor Set H1365

- For removing broken screws, bolts and threaded parts. Spiral type flutes grip and remove the broken part
- Precision Chrome Molybdenum (48-52 Rockwell hardness), tapered and ground
- Comes in a convenient vinyl pouch



	Screw or Bolt Size	Drill Size
<b>H1365A</b>	1/8 - 1/4"	1/16"
<b>H1365B</b>	1/4 - 5/16"	7/64"
<b>H1365C</b>	5/16 - 7/16"	5/32"
<b>H1365D</b>	7/16 - 9/16"	7/32"
<b>H1365E</b>	9/16 - 3/4"	17/64"



**WARNING:** always wear safety goggles

**Thread File (Coarse S.A.E.)****H1440**

- **11, 12, 13, 14, 16, 18, 20, 24** (threads / inch)

**Thread File (Fine S.A.E.)****H1441**

- **9, 10, 12, 16, 20, 27, 28, 32** (threads / inch)

**Thread File (Metric)****H1442**

- **0.75, 1.0, 1.25, 1.50, 1.75, 2.00, 2.50, 3.00mm**



H1440 - H1442

**Rethreader Die Sets**

- Hex shape lets you use a common socket for a holder
- Will quickly and safely repair damaged threads on bolts or rods
- Each set packed on ball chain

PROD. NO.	Pieces	Type	Contents
<b>H1345</b>	7	Fine	<b>1/4, 5/16, 3/8, 7/16, 1/2, 9/16, 5/8</b> <b>6mm x 1.0, 7mm x 1.0, 8mm x 1.25,</b>
<b>H1346</b>	5	Metric	<b>10mm x 1.50, 12mm x 1.50</b> <b>Use H1346-11 for 7mm x 1.0 Die</b>

**43 PC Rethreading Die Set – S.A.E. / Metric****H3573**

- A comprehensive re-thread kit for repairing or renewing damaged threads on nuts, bolts or studs
- Hex-shaped for socket or wrench use
- Comes in a convenient blow mould storage case

21 DIES		19 TAPS		3 Thread Files (4 sided)	
<b>UNC - National Coarse (Silver)</b>		<b>UNC - National Coarse (Silver)</b>		<b>H1440</b>	S.A.E. Coarse <b>11, 12, 13, 14, 16, 18, 20, 24</b>
<b>H3573-10</b>	1/4"-20 UNC	<b>H3573-17</b>	1/4"-20 UNC	<b>H1441</b>	S.A.E. Fine <b>9, 10, 12, 16, 20, 27, 28, 32</b>
<b>H3573-11</b>	5/16"-18 UNC	<b>H3573-18</b>	5/16"-18 UNC	<b>H1442</b>	Metric <b>0.75, 1.00, 1.25, 1.50, 1.75, 2.00, 2.50, 3.00mm</b>
<b>H3573-12</b>	3/8"-16 UNC	<b>H3573-19</b>	3/8"-16 UNC		
<b>H3573-13</b>	7/16"-14 UNC	<b>H3573-20</b>	7/16"-14 UNC		
<b>H3573-14</b>	1/2"-13 UNC	<b>H3573-21</b>	1/2"-13 UNC		
<b>H3573-15</b>	9/16"-12 UNC	<b>H3573-22</b>	9/16"-12 UNC		
<b>H3573-16</b>	5/8"-11 UNC	<b>UNF - National Fine (Black)</b>			
<b>UNF - National Fine (Black)</b>		<b>H3573-30</b>	1/4"-28 UNF		
<b>H3573-23</b>	1/4"-28 UNF	<b>H3573-31</b>	5/16"-24 UNF		
<b>H3573-24</b>	5/16"-24 UNF	<b>H3573-32</b>	3/8"-24 UNF		
<b>H3573-25</b>	3/8"-24 UNF	<b>H3573-33</b>	7/16"-20 UNF		
<b>H3573-26</b>	7/16"-20 UNF	<b>H3573-34</b>	1/2"-20 UNF		
<b>H3573-27</b>	1/2"-20 UNF	<b>H3573-35</b>	9/16"-18 UNF		
<b>H3573-28</b>	9/16"-18 UNF	<b>Metric (Gold)</b>			
<b>H3573-29</b>	5/8"-18 UNF	<b>H3573-43</b>	6MM x 1.00		
<b>Metric (Gold)</b>		<b>H3573-44</b>	8MM x 1.25		
<b>H3573-36</b>	6MM x 1.00	<b>H3573-45</b>	10MM x 1.25		
<b>H3573-37</b>	8MM x 1.25	<b>H3573-46</b>	10MM x 1.50		
<b>H3573-38</b>	10MM x 1.25	<b>H3573-47</b>	12MM x 1.25		
<b>H3573-39</b>	10MM x 1.50	<b>H3573-48</b>	12MM x 1.50		
<b>H3573-40</b>	12MM x 1.25	<b>H3573-49</b>	12MM x 1.75		
<b>H3573-41</b>	12MM x 1.50				
<b>H3573-42</b>	12MM x 1.75				



**WARNING:** Do not use with impact or power tools

## 5/16" Side Terminal Wrench

H3125

- Designed to easily remove 5/16" side terminal battery bolts
- Insulated handle to prevent electrical shock
- Reversible **5/16" ratcheting box wrench** allows for quick and effective terminal bolt removal



## Post and Terminal Cleaning Brush

H1007

- Remove corrosion quickly and safely. Cleans battery post and terminals for perfect electrical contact
- Also useful as a wire cleaning brush for cleaning 1/2" copper pipe before sweating
- Metal case included



## Post & Clamp Cleaner

H1677

- Quickly and safely cleans even the most corroded terminals
- Double ended post cleaner handles both the positive and negative posts
- The tapered reamer cleans both size terminals
- Constructed of high quality steel and shock proof plastic



## Post & Terminal Cleaner

H3391

- Cleans and reams battery posts and terminals
- Post cleaners marked with positive and negative symbols for easy identification



# BATTERY CARRIER

## Grip-Tight Battery Carrier

H1279

- For most 6 and 12 volt batteries
- Rugged, zinc plated steel jaws grip battery securely for lifting
- Acid resistant, non-conductive strap
- Designed to carry side terminal or post batteries
- Easy one hand control



## TESTING EQUIPMENT

### 100 Amp Analogue Load Tester

**H3432**

- **Tests 6 and 12 volt batteries up to 1,000 CCA**
- Tests battery state of charge, battery cranking ability, charging system output and starter condition
- Top mounted rocker switch is more convenient and easy to use
- Rubber insulated carrying handle for both comfort and safety
- Unit does not contain asbestos
- Accurate and shock resistant movement
- Easy to read meter
- Heavy duty colour coded, insulated clamps
- Durable, ventilated blue enamel steel case
- Complete tests done in 10 seconds
- Outside power is not required
- True 100 amp load capacity

### 100 Amp Digital Load Tester

**H3650**

- **Test 12 volt batteries only up to 1,000 CCA**
- Microprocessor controlled design guarantees an easy & accurate load test and no need to time yourself
- Unique 3 step design: LED polarity checking function, battery state of charge & charging system test readout
- Check both battery and charging systems
- Durable, ventilated enamel steel case
- Completely portable; outside power is not required
- True 100 amp load capacity
- Tests: battery state of charge, battery cranking ability, charging system output starter test

### 500 Amp Carbon Pile Tester

**H3655**

- **Tests batteries up to 1,000 CCA**
- Colour-coded, temperature compensation pass/fail bands on the voltmeter insures precise battery load test results
- Separate voltmeter and ammeter, for easy monitoring
- Fully insulated, heavy duty, colour coded battery clamps & wire leads
- For **12V batteries**, alternators, regulators & starters systems
- Designed with built in 15 second load warning beeper
- Meets UL and CE standards
- The JET ADVANTAGE: There are many 500 amp carbon pile battery tester and charging system analyzers in the market. While they all look the same from the outside, our unit has many important features that ensure a premium quality tester. Our carbon piles are made from the best quality, superior performing materials. Our steel parts are made with patented "constant-pressure/constant current" steel. The fasteners and soldering materials and assembly technology insure the components and connection stay secure. We use heavy duty 4 gauge welders' grade cable wire where competitors may use lighter gauge cable. These superior components and design qualities offer greater stability and more accurate readings while minimizing heat build up.

**Circuit Tester – 6/12 Volt** **H1090**

- Test electrical circuits, relays, bulbs, and switches
- Attach the ground clip to any good electrical ground and touch the probe to the hot end. If the bulb lights up, the circuit is good
- Bulb will take a nominal overload for safety
- Uses standard replacement bulb
- Hi-impact, no shock, plastic case
- Replacement Bulb: **H1090C**



**Continuity Tester** **H1304**

- Self-powered tester will check all voltage circuits and wiring, with the vehicle power off
- Uses standard AA battery. Battery included
- Test radio, T.V., appliances, electrical circuits, switches, voltage regulators, coils, fuses, condensers, armature and alternator diodes
- Bulb is mini screw base 1.5 V industry standard No. 112, purchase locally
- Lead is **36" long**



**Circuit Tester – Deluxe 36 Volt** **H1493**

- This unit does it all. It will test all voltages from **6 – 36 volts**
- A special high voltage neon tube will also let you test spark plugs and spark plug wiring
- The coiled wire lead extends up to 6 feet and retracts compactly
- Heavy duty large type clamp
- A very good all around tester
- H1090C Replacement Bulb



**Circuit & Polarity Tester - Computer Safe** **H3068**

- Designed to be used on all **12 volt** circuits including automotive computer circuits without damage to sensitive electronic components
- It draws less than 21 milliamps at 12 volts DC with an operating range of 3 - 15 volts
- Has a long life LED bulb
- Glows **RED** to indicate positive polarity at probe and **GREEN** to indicate negative polarity



**Circuit Tester With Buzzer - 6/12/24 Volt** **H3344**

- Bulb lights and buzzer sounds when positive contact has been made
- Ideal for use in tight spaces or under bright lights where a light is difficult to see
- Tests **6 - 12 - 24 volt** "power-on" circuits
- Clip enclosed in anti-shock boot
- Features long life LED bulb
- **Extra long 42" 16 - gauge wire**



**Remote Starter Switch** **H1361**

- Remote switch allows the mechanic to crank engine from outside of vehicle while keeping hands away from fan blades, gears, or other moving parts.
- Heavy duty switch contacts reduce arcing
- May be used to open and close other low voltage circuits.
- Leads are **35" long**





## SPARK PLUG/IGNITION TOOLS

### Ford® Triton Spark Plug Thread Repair Kit

**H3660**

- Designed to aide in repairing spark plug threads damaged on Ford® Triton Modular Engines - 1996-2003 - 4.6LT, 5.4LT, 6.8LT V-10
- Becoming one of the most asked for repairs as these engines age
- Repair damaged cylinder heads from spark plug thread erosion and shooting spark plugs out during operations with a patented "Alloy Steel Insert"
- Foolproof repair system that is fast, cost effective and simple to use
- Takes as little as 15 minutes, to no more than 45 to repair one cylinder

**Kit Contains:**

- Core drill, guide, hose assembly, instructional DVD, 6 -M14 x 1.25 x 19mm O.D. alloy inserts, all in a blow mould case
- Replacement Parts: **H3660-10** spark plug insert



### Ford® Triton Spark Plug Shield Extractor Kit

**H3661**

- Designed to extract frozen or broken spark plug ground electrode shields in Ford® Triton engines 2004 to present – 4.6LT, 5.4LT, 6.8LT V-10
- The elongated plug has a stainless steel shield – as the carbon deposit builds-up, the shield sticks and stays in the cylinder head spark plug well
- Use the specially machined guide with tap 9mm x 8"L (203.2mm) to tap the shield
- Use the extractor to pull out the stainless steel sleeve
- Problem solved; saving time and a huge expense

**Kit Contains:**

- 1 each: guide, Tap 9mm x 8"L (203.2mm), extractor, nut, washer and 4 rubber stopper caps, all in a blow mold case



### Ford® Triton Spark Plug Porcelain Extractor Kit

**H3659**

- Designed to extract frozen or broken porcelain part of the spark plug in the 3 Valve Ford Triton engines (2004 to present)
- Using these special tools and a strong epoxy you should be able to extract the broken porcelain left behind when spark plug removal was attempted
- The advantage of this method of extraction is to prevent broken pieces of porcelain from entering the combustion chamber
- Ford specifically does NOT recommend pushing the broken porcelain down into the cylinder, doing so would mean the removal of the cylinder head

**Kit Contains:**

- 1 – Epoxy applicator with guide, 1 – epoxy electrode applicator and extractor assembly, 1 – Small tube of bonding epoxy (Loctite)
- Replacement epoxy. Use Loctite No. 638 or Permatex No. 64000 or 64050
- Replacement Parts: **H3659-10** epoxy applicator  
**H3659-11** epoxy pins – 10 pack



## Spark Plug Thickness Gauge - Regular Range

H1274

- Popular, round pocket size wire gauge marked in thousandths on one side, metric on the other
- Includes electrode adjuster
- Gap Size: **.025, .030, .034, .035, .040, .045**

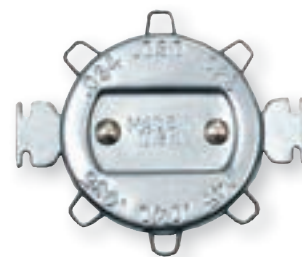

## Spark Plug Gauge and Gapper

H3116

- For standard and H.E.I. ignition
- Has tapered ground edge for gapping plugs. Adjusting hole with flange to adjust side wire without pressuring centre electrode
- Has both metric and decimal markings
- Gaps all plugs from: **.020 - .100 (0.50 - 2.5mm)**



## Spark Plug Thread Chasers

H1066

- For spark plug holes
- Chaser cleans threads of dirt, carbon build-up and metal particles
- Services most applications including compacts and subcompacts
- Rubber ring holds chaser firmly in socket
- Dual Size: **14mm and 18mm**
- Use with 13/16" deepwell socket



## 5 Piece Magnetic Spark Plug Socket Set

H3704

- Long reach magnetic swivel spark plug socket set
- For hex sizes 5/8", 13/16" and the new 9/16" on Ford® Triton engines
- Made from CrV steel, with a bright hard chrome finish

### Set Includes:

- 3/8" Dr x 9/16" HEX x 2-1/2" (66mm) Long
- 3/8" Dr x 5/8" HEX x 4" (101.6mm) Long
- 3/8" Dr x 5/8" HEX x 6" (152.4mm) Long
- 3/8" Dr x 5/8" HEX x 11" (279.4mm) Long
- 3/8" Dr x 13/16" HEX x 6" (152.4mm) Long



## ELECTRICAL TESTER

### Digital Automotive Multimeter

H3630

- Full-range - performs complete tune-up and troubleshooting tests on all vehicles
- Includes tests such as tach and dwell, fuel injectors, sensors, alternators, spark plug wires, ignition and charging systems, battery condition and cranking voltage
- Easy-to-read digital LCD
- Data hold function
- Computer safe

#### Functions:

DC Volts  
AC Volts  
DC Amps  
OHMS  
Freq.  
Dwell  
Tach  
Temp  
Diode check  
Continuity  
Transistor hFE

#### Measuring Range:

200m-2-20-200-1000V  
200-750V  
20m-200m-10A  
200-2k-20k-200k  
20kHz  
3-4-5-6-8CYL  
3-4-5-6-8CYL (X10RPM)  
-40° C/-40°F / 1,400°C/2,552°F  
3V/1mA  
Audible BEEP  
Vce≈3v, 1b≈10μA

#### Features:

- 10M Input Impedance
- Auto reverse polarity
- Auto zero adjust
- Over range Indication
- Overload protection
- Low battery indicator
- Fuse Protection
- 9-Volt power
- Auto power off
- 9V Battery

#### Accessories:

- Colour-coded test leads
- Inductive spark pickup clamp
- Temperature Probe
- Detailed manual
- Holster



PH3630-10  
Lead Set

PH3630-12  
Inductive Clamp

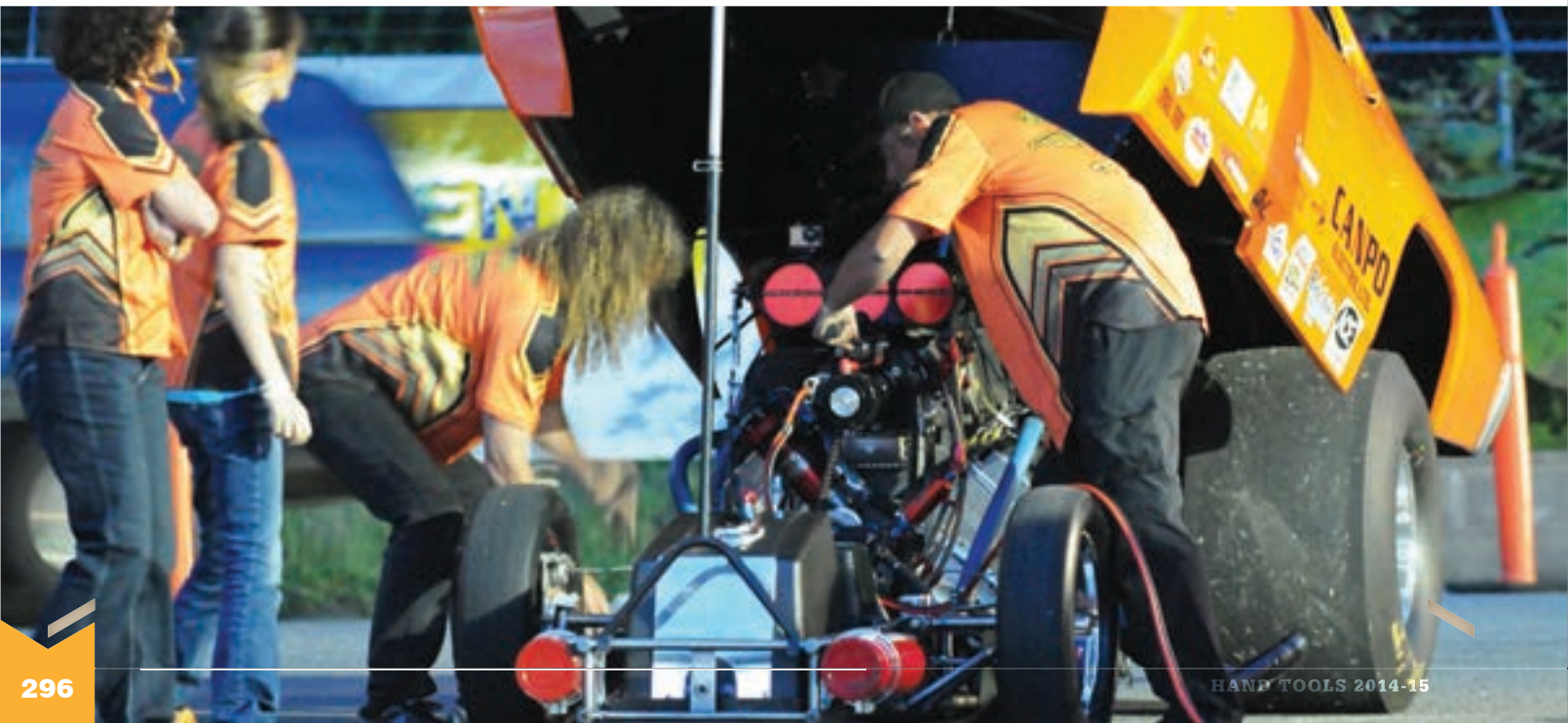







## MISCELLANEOUS

### Mechanics 4-In-1 Pick Set

H1244

- Good quality metal scribes designed at different angles to meet the mechanic's needs
- Comes complete with 4 picks and one master handle
- Handy storage pouch



### Telescopic Mirror (2-1/4" Round Face)

H1105

- Double ball joint links swivel mirror for viewing to 360°
- Linkage designed to withstand constant repositioning of mirror, to move freely and yet hold desired position
- Telescoping handle: **9-1/2" - 14"**

### Telescopic Pocket Mirror (1" x 2" Oval Face)

H1230

- Double ball adjustment head
- Convenient pocket clip
- Telescoping handle: **6-3/4" - 24-3/4"**

### Telescopic Mirror - Large Rectangular Face

H3103

- Double ball joint hinge adjusts to almost any angle
- Handle end has easy grip vinyl coating
- Telescoping handle: **11" - 15-1/2"**

## MAGNETIC PICK-UP TOOLS

### Flexible Pick-Up Tool

H1080

- Bends in any direction to hold or pick up objects
- Handy squeeze action gives close control
- Mechanical fingers grip securely
- Reach: **15"**

### Adjustable Pocket Telescoping Magnet

H1386

- Extends up to **23"**
- Lifts up to **3-1/2 lbs**

### Telescoping Magnet - Long Adjustable

H1122

- This heavy duty Alnico magnet will lift many times its own weight
- The flex head gets into tight places
- Bright plated with a comfortable plastic handle
- Shaft telescopes from **16-3/4" - 26-3/4"**
- Lifts up to **5 lbs**

### Flexible Magnetic Pick Up Tool

H1229

- Flexible Alnico 5 magnetic pickup tool with knurled handle
- Flex shaft holds its set
- Overall length: **21"**
- Diameter: **5/16"**
- Lifts up to: **5-1/2 lbs**

# MAGNETIC PICK-UP TOOLS



## Bend-It Magnetic Pick-Up Tool

H3086

- 19" bendable shaft to shape and reshape time and time again
- Retrieves all types of metal objects in those hard to reach areas
- The neodymium iron-boron magnet has out-performed other magnets its size by 4 to 1
- Lifts up to: **1-1/2 lbs**



# TIRE PRESSURE GAUGES

## Pencil Tire Pressure Gauge - Chrome Plated

H1141

- Quality gauge ensures accuracy, long life and trouble-free performance
- High chrome plated finish
- Calibrated on two sides from **5 - 50 PSI** and in metric **40 - 350 kPa**
- Comes with handy pocket clip

## Pencil Tire Pressure Gauge - Metal Body

H3262

- Durable metal chuck and body
- Handy pencil style with pocket clip
- Four sides plastic slide bar
- Calibrated in **5 - 50 PSI** and **40 - 350 kPa**

## Dual Chuck Tire Gauge - Small

H3162

- Accurately measures from **10 - 120 PSI**. Also calibrated in Kgs
- Chrome plated ABS dual offset heads. Stem enclosed in metal body
- Shockproof
- Includes spring pocket clip
- Overall length: **6-3/4"**



## Tire Service



Distributors  
please note :  
H3262 tire gauges sold in  
an attractive 24 pack POP  
display only



## TIRE PRESSURE GAUGES

### Dual Chuck Tire Pressure Gauge – Large

**H1503**

- Dual chuck for use on trucks and passenger cars. Will withstand rugged use
- Angled dual chuck to reach inner and outer tire valves
- Indicator bar calibrated **10/200 PSI in 2 lb. increments** and **metric 1/14 Kgs**
- Includes hang up ring
- Overall length: **13"**



Head assembly swivels 360°



Easy to read recessed sight glass

### 360° Swivel Head Truck Tire Gauge - Angle & Straight-On

**H3274**

- Heavy duty truck tire gauge
- Head assembly swivels 360°
- Easy-to-read, recessed sight glass
- Needle holds reading until bleeder valve is released
- High chrome plated finish
- Pressure range **10 - 120 PSI in 2lb increments**
- Overall length: **11-7/8"**

### 360° Swivel Head Digital Tire Pressure Gauge

- Simple to operate
- Clear, large LCD display (30mmx 15mm) with built-in backlight
- Audible buzzer
- Replaceable battery (LED), lithium and LR44 alkaline
- Measuring range to **150 PSI**.
- Calibration in PSI, Bar, Kg/cm<sup>2</sup> and kPa.
- Resolution: **0.5 PSI (0.05 Bar or 5 kPa)**
- Accuracy: +/- 1% + 0.5 PSI at 100 PSI and +/- 2% + 0.5 PSI at 150 PSI
- Operating Temperature: **50°F – 86°F (10°C – 30°C)**
- Head assembly swivels 360°
- Straight and 30° reverse angle chuck for monitoring inside and outside dual wheels



Large LED display

PROD. NO.

Overall Length

Type

**H3276**

11-7/8" x 7-1/4"

Angled Head Chuck

### Dial Type Tire Gauge

**H3264**

- Needle holds readings until released by pressing relief button
- Zinc Alloy body, all chrome plated with acrylic lens
- Range: **10-100 PSI, in 2lb increments with metric kPa reading**



**Dial Type Tire Pressure Gauge (10-100PSI)  
– 12 Piece Counter Display** **H3266**

- Needle holds readings until released by pressing relief button
- Zinc Alloy body, all chrome plated with acrylic lens
- Range: **10-100 PSI, in 2lb increments with metric kPa reading**
- Distributors please note: H3266 tire gauges are sold in an attractive 12 pack P.O.P. display only



## TIRE VALVE TOOLS

**Valve Core Tool - 4-In-1 Style** **H1142**

- Removes and replaces tire valve cores, rethreading inside and outside of valve stem
- E-Z out for backing out valve insides when shoulders are broken off
- Made of high grade tempered steel.
- Nickel plated



**Tire Tread Depth Gauge** **H1151**

- Accurately determines the amount of tread left on tire
- Brass construction with high chrome plated finish
- 3 sides calibrated in **1/32" increments up to 1" depth**
- 3 sides calibrated in **millimeters in increments up to 25 mm depth**
- Handy pocket clip



**Valve Core Tool (5" Long)** **H1147**

- A compact tool with aluminum handle and steel shaft
- Handle provides a sturdy grip
- For standard size valve core
- 5" overall length



## PLIERS FOR WHEEL WEIGHTS

**Wheel Weight Pliers with Spring Loaded Handles** **H1116**

- Remove and install all types of clip-on wheel weights
- Invisible spring loaded handle keeps the jaws in the open position for ease of operation
- Ergonomic handle design with coated grips for comfort
- Built in cutter to cut wheel weights
- Handle ends have a flat or pointed end for prying or lifting
- Made of Chrome Vanadium steel
- Length: **9-3/4"**





Rubber protected



360° swivel easy to read gauge



H1143



H1145



H1144



H1302



H1301

## AIR INFLATOR GAUGES

### Air Line Inflator With Tire Gauge – Bayonet / Slide Type

H3282

- 2-in-1 tool, Inflate and measure tire pressure levels
- Lever action
- Heavy duty construction provides long service life
- Zinc chrome plated body with brass internal parts
- 360° swivel dual foot chuck
- Includes a 1/4" x 12" air hose rated at W.P. 300 PSI
- Range: **10 – 90 PSI in 2 lb increments**

### Air Line Inflator With Tire Gauge - Dial Type

H3284

- 3-in-1 tool, air line inflator & deflator with tire pressure gauge
- Heavy duty construction provides long service life
- 360° swivel easy-to-read gauge with heavy duty rubber gauge head protector
- Includes a 1/4" x 5 foot air hose rated at W.P. 300 PSI with 360° swivel straight safety clip-on air chuck
- 1/4" NPT Female
- Range:  
**10 – 170 PSI in 2 lb increments**  
**70 - 1200 kPa in 10 lb increments**

## AIR CHUCKS

### Single Face Air Chuck

H1143

- Direct air line chuck with shut off valve built in chuck head
- Thread Size: **1/4" NPT**

### Single Face Air Chuck With Safety Clip

H1145

- Direct air line chuck with shut off valve built into chuck head
- Safety clip holds air chuck to valve stem
- Brass
- Air inlet (NPT) 1/4"

### Straight-On Air Chuck With Safety Clip

H1144

- Direct air line chuck with shut off valve built into chuck head
- Safety clip holds air chuck to valve stem
- Brass
- Thread size **1/4" NPT female**

### Dual Foot Air Chuck - Angle & Straight-On

H1302

- 30° angle & straight-on chuck with deep well lock
- Locks onto valve mouth when fitted
- Chrome plated finish
- Brass tube
- Air inlet (NPT) 1/4"
- Overall length: **6-5/8"**

### Dual Foot Air Chuck

H1301

- Direct air line chuck with shut off valve built into chuck head
- Thread Size: **1/4" NPT**
- Overall length: **5-1/4"**

## 11 PC Pry Removal Tool Set H3662

- Designed for the disassembly of door panels, dashboards, fascia, trim strips, bezels, window installation and more
- Specially constructed of impact resistant nylon, this set is the only one of its kind in the world
- It will not scratch or mar delicate surfaces like some metal versions
- Comes complete in a durable canvas storage roll pouch
- The pouch forms its own standing display or lays flat for easy access to tools while on the job
- Ideal for the automotive, marine, aviation and other industries where surface care is required

**Set Includes :**

- H3362-10** Angled clip panel remover
- H3362-11** Flat clip panel remover
- H3362-12** Panel remover
- H3362-13** Sharp panel remover
- H3362-19** Wide type remover
- H3362-14** Straight panel remover
- H3362-15** Clip panel remover
- H3362-16** Pull type remover
- H3362-17** Handy remover
- H3362-18** Narrow type remover
- H3362-20** Upholstery remover



## 5 PC Trim Panel Removal Set H3664

- Variety of popular body trim panel removal tools
- Designed to prevent the trim panel fastener from pulling through the panel
- Ergonomic handle with "SVCN" satin chrome plated steel shafts
- Comes with a reusable storage tray

**Set includes:**

- **H3666** Large "V" Notch Tip, Length **9" (228.6mm)**
- **H3668** Small "V" Notch Tip, Length **8-1/4" (209.5mm)**
- **H3670** 1/4" "U" Notch Tip, Length **8-3/4" (222.2mm)**
- **H3672** 5/16" "U" Notch Tip, Length **8-3/4" (222.2mm)**
- **H3674** Square Notch Tip, Length **9-7/8" (250.8mm)**





HTA1106



HTA1109



HTA1118



HTA1125



HTA1136



HTA1150



HTA1153



HTA1154



HTA1156



HTA1216 (HTA1118, HTA1144)



HTA1308 (Includes HTA1106, HTA1118, HTA1144)

## CHROME SERIES - PROFESSIONAL DUTY

- All gauges are for 12 volt negative ground systems
- Accurate, reliable gauges, **2-1/16" dual S.A.E. and metric dials**
- Chrome bezels and panels with optional black vinyl decoration supplied
- White print and red pointers on black background. OEM backlit illuminated

### Kit includes:

- Adaptors and senders to fit most popular applications.
- Full installation instructions
- OHMS rating for oil pressure gauges: 0 PSI = 225 - 259 OHMS, 50 PSI = 93 - 113 OHMS, 100 PSI = 30 - 38 OHMS
- OHMS rating for electrical temperature gauges: room temp = 1,730 OHMS, 130°F = 528 OHMS, 190°F = 165 OHMS, 290°F = 36 OHMS

PROD. NO.	Description	Range	Sweep	Includes
<b>HTA1106</b>	Ammeter	60-0-60+	90°	-
<b>HTA1109</b>	Voltmeter	8-16 Volts	90°	-
<b>HTA1118</b>	Mechanical Water Temperature - 66° Capillary Tube	130°-280°	90°	1/2" and 3/8" NPT Adaptors
<b>HTA1125</b>	Wide Sweep Mechanical Water Temperature - 66° Capillary Tube	130°-280°	270°	1/2" and 3/8" NPT Adaptors
<b>HTA1136</b>	Electrical Water or Oil Temperature	130°-290°	90°	Sender Unit
<b>HTA1144</b>	Mechanical Oil Pressure	0-80 PSI	90°	72" Nylon Tube with Adaptors
<b>HTA1150</b>	Wide Sweep Mechanical Oil Pressure	0-100 PSI	270°	72" Nylon Tube with Adaptors
<b>HTA1153</b>	Electrical Oil Pressure	0-100 PSI	90°	Sender Unit
<b>HTA1154</b>	Manifold Vacuum	0-25 lbs	270°	72" Plastic Tube with Adaptors
<b>HTA1156</b>	Mechanical Water Temperature - 96° Capillary Tube	130°-280°	90°	1/2" and 3/8" NPT Adaptors

PROD. NO.

**HTA1216** Dual Oil Pressure & Water Temperature Gauge Set**HTA1308** Triple Ammeter, Oil Pressure & Water Temperature Gauge Set



# CHROME SERIES - HEAVY DUTY & MARINE



- Designed for heavier duty and marine applications.
- Cross coil torque meter and oil dampened needle movements ensure steady readings.
- They are built with non-corrosive, durable plastic cases, with a water resistant seal and stainless steel bezels
- **2-1/16" Diameter**

**Kits include:**

- Electrical Gauges
- 12 Volt Negative Ground Systems
- OEM Backlit Illuminated
- Mounting Hardware & Installation Instructions (no connection wires)
- Clamshell Packaging
- Sender Thread 1/8 - 20 NPT



HTA1401



HTA1000



HTA1402

PROD. NO.	Description	Range	Sweep	Includes
<b>HTA1000</b>	Hour Meter - Rear Mount	0-99999.9	-	-
<b>HTA1401</b>	Electrical Oil Pressure	0-100 PSI	180°	Sender Unit
<b>HTA1402</b>	Electrical Water Temperature	100°-280°	180°	Sender Unit
<b>HTA1403</b>	Voltmeter	8-16 Volts	180°	-
<b>HTA1404</b>	Fuel Level Gauge	-	180°	-



HTA1404



HTA1403



HTA1831



HTA1833

## EASY-READ GAUGE KITS WHITE FACE

- **2-1/16" dials**
- OEM backlit illuminated
- S.A.E. and metric readings
- Wide sweep for accurate readings
- Black deluxe panels and bezels
- For all 12 Volt negative ground systems

**Kit Includes:**

- Adaptors, installation hardware, instructions and lighting



HTA1835 (Includes HTA1831, HTA1833, HTA1834)



HTA1832

PROD. NO.	Description	Range	Sweep	Includes
<b>HTA1831</b>	Mechanical Oil Pressure	0-100 PSI	270°	Sender Unit
<b>HTA1832</b>	Ammeter	-60-0-60+	90°	-
<b>HTA1833</b>	Voltmeter	8-16 Volts	90°	-
<b>HTA1834</b>	Mechanical Water Temperature	130°-280°	270°	Sender Unit
<b>HTA1835</b>	Triple Voltmeter, Water Temperature & Oil Pressure Gauge Set			



HTA1834



HTA1820



HTA1819



HTA1830

## TACHOMETERS

- 0-8,000 RPM
- 270° sweep
- Illuminated
- Red adjustable kit pointer
- All metal case
- Wide chrome plated bezel
- Heavy duty cross-coil meter
- 360° universal mounting
- Works on 12 Volt conventional or electronic ignition systems
- For 4, 6 or 8 cylinder applications
- Hardware and instructions

PROD. NO.	Size	Description
HTA1819	2" Dial Compact Tachometer	White Print and Red Pointer on Black Background
HTA1820	3-1/2" Dial Tachometer	White Print and Red Pointer on Black Background
HTA1830	Easy-Read 3 1/2" Dial Tachometer	Easy Read, Black Print and Pointer on White Background



## HTA SERIES REPLACEMENT PARTS

PROD. NO.	Description
HTA1108A	12 Volt Bulb for all 2 1/16" Gauges
HTA1118A	1/2" adaptor-Mech. Water Temp
HTA1118B	3/8" adaptor-Mech. Water Temp.
HTA1136A	Metric Fittings - Mech. Temp. Gauges
HTA1136B	Sending Unit Kit Elect. Temp.
HTA1136C	1/8" x 1/4" adaptor - Elect. Temp.
HTA1144A	Oil Press. Kit, 72" tube and adaptors
HTA1144B	Oil Press. Kit, 144" tube and adaptors
HTA1144C	5/16"F x 1/8" M Oil Pressure adaptor
HTA1146A	Metric Fitting Kit
HTA1152A	Elect. Oil Press. Sender for HTA1153
HTA1312A	2-16" Chrome Single Gauge Panel Bezel
HTA1312B	2-16" Chrome Dual Gauge Panel Bezel
HTA1312C	2-16" Chrome Triple Gauge Panel Bezel

## ELECTRICAL FUEL LEVEL GAUGE KIT

### Electrical Fuel Level Gauge Kit HTA1117

- Adjustable. Fits tanks 5" to 27" in depth, right or left hand swing
- Gauge design appearance and size are the same as our standard chrome series gauges
- For 12 Volt negative ground system

#### Kit Includes:

- Gauge, panel and sender
- OHMS rating
- Empty-240 OHMS
- FULL-33 OHMS





# Precision/ Electronic Measuring Tools

ELECTRONIC  
THERMOMETERS  
DIGITAL METERS  
CALIPERS  
MICROMETERS  
GAUGES  
DIALS

## CALIPERS

▼ *Hand Tools in this section feature:*

- All JET calipers feature Stainless Steel construction for professional use

### LCD Digital Calipers

- Four measurements – inside, outside, depth, step
- Extra large LCD screen is easier to read
- Professional quality hardened stainless steel construction
- Precision ground measuring surfaces
- With data output interface
- Fine adjustment thumb wheel
- Comes with high impact plastic storage case

PROD. NO.	MOD. NO.	Type	Range	Increments
<b>310131</b>	JEDC-6	Electronic	<b>0-6"</b> (150mm)	0.0005"/0.01mm
<b>310132</b>	JEDC-8	Electronic	<b>0 - 8"</b> (200mm)	0.0005"/0.01mm
<b>310136</b>	JEDC-12	Electronic	<b>0 - 12"</b> (300mm)	0.0005"/0.01mm



### LCD Digital Calipers - Fractional

- Unique LCD can display measurements in Metric, S.A.E. and fractional formats
- Easily converts measurements with the touch of a button
- Four measurements - inside, outside, depth, step
- Professional quality hardened stainless steel construction
- Precision ground measuring faces
- Auto power off
- Fine adjustment thumbwheel

PROD. NO.	MOD. NO.	Type	Range	Increments
<b>310133</b>	JEDC-6F	Electronic	<b>0-6"</b> (150mm)	0.0005" / 0.01mm / 1/64"



310131

#### Four button control panel:

- power on/off switch (ON/OFF)
- zero setting at any position (ZERO)
- data hold function (HOLD)
- instant S.A.E. / Metric conversion (MM/IN)



310133

### Vernier Calipers

- Professional quality hardened stainless steel construction
- Four measurements – inside, outside, depth, step
- S.A.E. scale
- Permanent abrasion resistant graduations
- Satin chrome finish
- Fine adjustment thumb wheel
- Screw lock mechanism

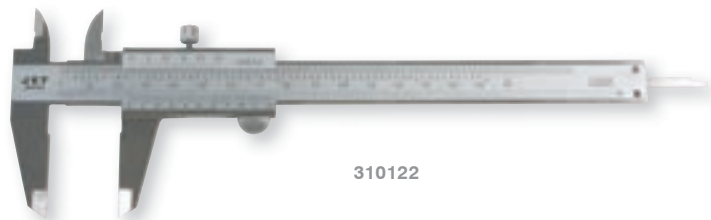

310122

PROD. NO.	MOD. NO.	Type	Range	Increments
<b>310122</b>	JVC-6	Vernier	<b>0 - 6"</b> (150mm)	0.001"

## Dial Indicator

- Knurled bezel rotates 360°
- Stainless steel rack and contact points
- Includes revolution counter
- Back lug of indicator can be swiveled 90° for easy clamping
- Easy to read white face dial
- Range 0 – 1", increments 0.001"
- Range per revolution 0.1"

PROD. NO.	MOD. NO.	Type	Range	Increments
<b>310502</b>	JDI-1	Dial	<b>0 - 1"</b>	0.001"

## LCD Digital Indicator

- Large LCD display for easy reading
- Stainless steel rack and contact points
- With data output interface
- Automatic power off

PROD. NO.	MOD. NO.	Type	Range	Increments
<b>310501</b>	JEDI-1	Digital	<b>0 - 1"</b> <b>(25mm)</b>	0.0005"/0.01mm'



# PRECISION MEASURING TOOL KIT

## 4 PC Precision Measuring Tool Kit **310991 / PMTK-4S**

- Kit includes: 6" digital calipers, 0 - 1" micrometer, 3" x 2" bevel edge precision square, and 6" precision rule
- Excellent kit for students, mechanics, millwrights etc.
- Calipers feature large screen, 0.0005" / 0.01mm increments
- Micrometer features spindle lock and ratcheting thimble, 0.0001" increments
- Square manufactured from high grade stainless steel to DIN 875 standard
- Square blade is bevelled on both sides and both edges for excellent sight line to work piece; notch on inside corner for clearance around burrs, dirt, etc.
- Stainless steel rule with 1/64", 1/32", 1/16", 1/8", 0.5mm, and 1mm increments
- High impact plastic case with die cut foam keeps tools secure





## MAGNETIC BASES

### Standard Style 310902 / JMB-1

- Rod and swivel style
- On / Off switch to release magnet
- Powerful magnet holds base firmly to metal host
- 3 dimensional central locking mechanism
- Complete with fine adjustment
- Can be used with most makes of dial indicators



### Flexible Style 310903 / JFMB-12

- 12" flexible arm holds dial indicator firmly in any position
- On / Off switch to release magnet
- Powerful magnet holds base firmly to metal host
- Stem flexes almost 360°



### Quick Set Style 310905 / JMB-2

- Fine adjustment screw controls all 3 joints for fast set up
- On / Off switch to release magnet
- Powerful magnet holds base firmly to metal host



## MICROMETERS



310206

#### Five button control panel:

- power on/off switch (ON/OFF)
- zero setting at any position (SET)
- instant S.A.E. / Metric conversion (MM/IN)
- clock mode / data output
- absolute / incremental measurement (ABS/INC)

### LCD Digital Outside Micrometer 310206 / JEOM-1

- Large LCD display for easy reading
- Precision machined carbide tipped measuring face
- Precision friction thimble for one hand operation
- IP54 moisture resistant construction
- Satin chrome finish – professional quality construction
- 0.00005" / 0.001 mm increments
- Comes **with high** impact custom plastic storage case Five button control panel: - power on/off switch (ON/OFF) - zero setting at any position (SET) - instant S.A.E. / Metric conversion (MM/IN) - clock mode / data output - absolute / incremental measurement (ABS/INC)



### 3 Piece Outside Micrometer Set 310210 / JOM-3S

- Precision machined carbide tipped measuring faces
- Precision ground and hardened one piece spindles
- Ratcheting friction stop provides uniform pressure
- Convenient lock holds spindle securely when transferring measurements
- 0.0001" increments
- Range: **0-3"**
- Contains 1 each of our **0 - 1", 1" - 2", and 2" - 3"** outside micrometers in a convenient custom made high impact plastic case
- Includes standards for both 1" - 2" and 2" - 3" models



310210

## Outside Micrometers - Open Stock

PROD. NO.	MOD. NO.	Type	Range	Increments
<b>310211</b>	JOM-1	Mechanical	<b>0 - 1"</b>	0.0001"
<b>310212</b>	JOM-2	Mechanical	<b>1 - 2"</b>	0.0001"
<b>310213</b>	JOM-3	Mechanical	<b>2 - 3"</b>	0.0001"



310212

## Depth Micrometer - Mechanical (0-6")

- Interchangeable extension rods feature precision lapped ends
- Ratcheting friction stop provides uniform pressure
- 4" precision ground hardened base
- 0.001" increments
- Satin chrome finish – professional quality construction
- Comes with high impact custom plastic storage case

PROD. NO.	MOD. NO.	Type	Range	Increments	Base Width
<b>310223</b>	JDM-6	Mechanical	<b>0 - 6"</b>	0.001"	4"



310223

# GAUGES

## Dial Bore (Cylinder) Gauge

- Used to measure the internal dimensions of work pieces such as cylinders, piping, tubing, etc.
- Allows cylinder wear measurements without removing pistons
- Unique guiding device that facilitates self centering
- Interchangeable extension anvils allow unit to measure a wide range of dimensions: S.A.E. 2" - 6"
- Extremely accurate
- Measures bores up to 6" deep
- Easy to read white face dial
- Comes with high impact custom plastic storage case

PROD. NO.	MOD. NO.	Measuring Range	Depth Range	Number of Anvils	Increments
<b>310511</b>	JBG-6	<b>2" - 6"</b>	6"	11	0.0005"



310511

## BRAKE AND ROTOR TOOLS

### ▼ Hand Tools in this section feature:

- All JET Brake and Rotor tools feature stainless steel construction for professional use



#### Four button control panel:

- power on / off switch (ON/OFF)
- zero setting at any position (SET)
- instant S.A.E. / Metric conversion (MM/IN)
- data hold function (HOLD)

### LCD Digital Disc Brake (Rotor) Caliper

- The ideal way to measure disc brake rotor thickness
- Both anvils are pointed to measure score depths
- With data output interface
- 0.0005" / 0.01 mm increments
- Comes with custom plastic case

PROD. NO.	MOD. NO.	Range	Increments
<b>310602</b>	JERG-1	<b>0 - 5"</b> (0 - 125 mm)	0.0005" / 0.01 mm

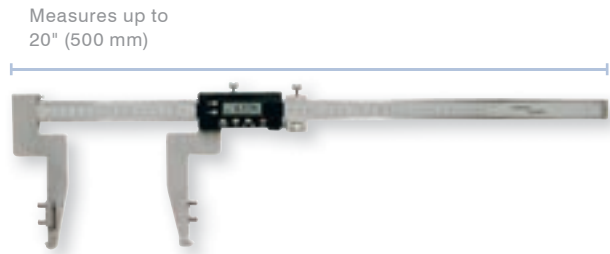

Measures up to  
20" (500 mm)

### LCD Digital Drum Caliper

- The ideal method to measure wear on brake drums
- 0 - 20" (500 mm) range
- With data output interface
- 0.0005" / 0.01 mm increments
- Comes with custom wood case

PROD. NO.	MOD. NO.	Range	Increments
<b>310604</b>	JEDG-1	<b>0 - 20"</b> (0 - 500 mm)	0.0005" / 0.01 mm



### LCD Digital Rotor Caliper (Wheel Stays On)

- For measuring disc brake rotor thickness without taking off the wheels
- All other features same as electronic rotor gauge (**310602**)
- 0 - 100 mm range
- Comes with custom plastic case

PROD. NO.	MOD. NO.	Range	Increments
<b>310603</b>	JERG-1WO	<b>0 - 4"</b> (0 - 100 mm)	0.0005" / 0.01 mm



#### Four button control panel:

- power on / off switch (ON/OFF)
- zero setting at any position (SET)
- instant S.A.E. / Metric conversion (MM/IN)
- data hold

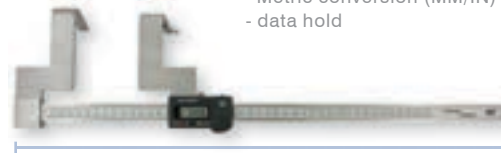

Measures up to  
17" (430 mm)

### LCD Digital Drum Caliper - (Wheel Stays On)

- For measuring wear on brake drums without taking the wheels off
- 0 - 17", 0 - 430 mm range
- 0.0005" / 0.01 mm increments
- Comes with custom wood case

PROD. NO.	MOD. NO.	Range	Increments
<b>310605</b>	JEDG-1WO	<b>0 - 17"</b> (0 - 430 mm)	0.0005" / 0.01 mm





# THERMOMETERS

If you are in the trades, we have the quality and performance you need to get the job done right.

## Non-Contact Infrared

- Allows accurate measurement of temperature without contact
- Gives instant readouts in real time
- Ideal for use in inaccessible areas and where moving parts or high heat make contact measurement dangerous
- Thousands of uses including automotive applications, food and beverage industries, chemical industries, cement plants, road building, HVAC, pool maintenance, etc.

PROD. NO. MOD. NO.	<b>310016</b> JIRT-450	<b>310018</b> JIRT-750
<b>Display</b>	3-1/2 digit (1999 count) LCD with back lighting	3-1/2 digit (1999 count) LCD with back lighting
<b>Measuring Range</b>	<b>-20°C to 450°C</b> <b>-4°F to 842°F</b>	<b>-50°C to 750°C</b> <b>-58°F to 1,382°F</b>
<b>Increments</b>	1°C / °F	0.1°C / °F up to 200°C / °F 1°C / °F over 200°C / °F
<b>Accuracy</b>	+/- 2°C or 2% of reading	+/- 2°C or 1.5% of reading
<b>Operating Temperature</b>	0°C to 50°C / 32°F to 122°F	0°C to 50°C / 32°F to 122°F
<b>Response Time</b>	1 sec app.	1 sec app.
<b>Field of View (Distance : Spot Size)</b>	8:01	12:01
<b>Spectral Response</b>	6 – 14µm	8 – 14µm
<b>Emissivity</b>	0.95 fixed	0.95 fixed
<b>Relative Humidity (Operating)</b>	Max. 80%	10% – 90%
<b>Over Range Indication</b>	LCD will show "OVER" and meter will beep	LCD will show "1"
<b>Power Off</b>	Automatic shut-off after 7 sec.	Automatic shut-off after 7 sec.
<b>Power Supply</b>	9V battery	9V battery
<b>Weight</b>	180 gram	290 gram
<b>Size</b>	159 x 79 x 57.2 mm	100 x 56 x 230 mm



310018



310016

## MULTIMETERS – DIGITAL

### ▼ Hand Tools in this section feature:

- Versatile meters for a wide range of electrical tests
- Features auto shut-off, large LCD display, low battery indicator, overload protection
- TPR shroud protects meter
- Can be used with clamp on adaptor for expanded versatility
- Includes test leads, K-type thermo-coupler and 9V battery



310006



310008

### Multimeter

- Designed to safety standard IEC-1010; CAT II 600V

PROD. NO.  
MOD. NO.

**310006**  
JDMM-200

Application	AC/DC current AC/DC voltage resistance capacitance frequency temperature diode check transistor hFE
<b>AC Current</b>	20u-20m-200m-20A
<b>DC Current</b>	20m-200m-20A
<b>AC Voltage</b>	20-200-750V
<b>DC Voltage</b>	200m-2-20-200-1000V
<b>Resistance</b>	200-2k-20k-200k-2M-20M-200 Mohms
<b>Frequency</b>	2k-20kHz
<b>Diode Check</b>	2.8V/1mA
<b>Capacitance</b>	2n-20n-200n-2u-20uF
<b>Temperature</b>	-40°C – 1000°C
<b>hFE</b>	Vce ~3V; 1b ~ 10Ua

### Multimeter - Auto Ranging

- Automatically sets correct range when test function is selected
- Mechanically prevents incorrect connection of test leads
- Data hold function
- Designed to safety standard EN61010-1; CAT II 600V

PROD. NO.  
MOD. NO.

**310008**  
JDMM-300

Application	AC/DC current AC/DC voltage resistance capacitance frequency temperature diode check duty cycle continuity check
<b>AC Current</b>	400u-4000u-40m-400m-4A-20A
<b>DC Current</b>	400u-4000u-40m-400m-4A-20A
<b>AC Voltage</b>	400mV-4V-40V-400V-750V
<b>DC Voltage</b>	400mV-4V-40V-400V-1000V
<b>Resistance</b>	200-4k-40k-400k-4Mohms-40 Mohms
<b>Frequency</b>	9.999Hz – 9.999MHz
<b>Diode Check</b>	Test current of 0.3mA, open circuit voltage of 1.5V
<b>Duty Cycle</b>	0.1% - 99.9%
<b>Continuity Check</b>	Threshold 30 ohms, continuity beeper 2.7 kHz
<b>Capacitance</b>	40nF-400nF-4uF-40uF-100uF
<b>Temperature</b>	-20°C – 760°C

**Automotive Multimeter** **H3630**

- Full-range - performs complete tune-up and troubleshooting tests on all vehicles
- Includes tests such as tach and dwell, test fuel injectors, sensors, alternators, spark plug wires, ignition and charging systems, battery condition and cranking voltage
- Easy-to-read digital LCD
- Data hold function
- Computer safe



**Clamp Meter**

- Takes measurements directly through clamp or with test leads
- Designed to safety standard IEC - 1010; CAT II 600V
- Includes zipper case, test leads and 9 volt battery

PROD. NO. **310022**  
MOD. NO. JDCM-2

Application	AC/DC current AC/DC voltage resistance frequency
<b>AC Current</b>	4A - 1000A
<b>DC Current</b>	4A - 1000A
<b>AC Voltage</b>	750V
<b>DC Voltage</b>	1000V
<b>Resistance</b>	200 kOhms
<b>Frequency</b>	2kHz

**AUTOMOTIVE MULTIMETER**  
See pages 292 in the Specialty Auto section for similar products

**Voltage Detector** **310041 / JVD-600**

- Non-contact detection of AC voltage from 100V to 600V
- Suitable for testing outlets or against cable insulation
- Flashing red LED and audible beep indicate voltage
- Built in LED flashlight and pocket clip
- Designed to safety standard CATIII 1,000V
- Always test on known live circuit before use







# Mechanic's Tools

PICKS  
HOOKS  
SCRAPERS  
PRY BARS

**317**



## CHISEL POINT SCRAPERS

▼ *Hand Tools in this section feature:*

- Extra stiff stainless steel blades with chisel points for the toughest scraping and cleaning jobs
- Ergonomic handle provides non-slip grip and maximum user comfort
- Blades double-riveted to handles for maximum strength
- Steel striking cap for extra tough scraping jobs

### 4 PC Chisel Point Scraper Set

**859341** / JCS-4S

- 1-1/4" Scraper
- 1-1/4" Bent Scraper
- 2" Scraper
- 3/4" Stubby Scraper

### Chisel Point Scrapers - Open Stock

PROD. NO.	MOD. NO.	Description	Blade Thickness
<b>859342</b>	JCS-125	<b>1-1/4"</b> Scraper	2.0mm
<b>859343</b>	JCS-125B	<b>1-1/4"</b> Bent Scraper	2.0mm
<b>859344</b>	JCS-200	<b>2"</b> Scraper	2.0mm
<b>859345</b>	JCS-2025	<b>3/4"</b> Stubby Scraper	2.5mm



859341

# PICK, HOOK AND SCRAPER TOOLS



▼ *Hand Tools in this section feature:*

- Exclusive ergonomic handle for maximum grip
- Premium grade Chrome Vanadium steel shafts
- Heat treated for maximum strength
- Heavy duty professional quality

## 5 PC Scraper Set

- Black Manganese Phosphate finish for corrosion resistance
- Precision ground edges

PROD. NO.	MOD. NO.	Length	Contents
<b>859304</b>	JPSS-5	1" x 8-1/2"	Short Scraper
		1/2" x 10"	Medium Scraper
		1" x 12"	Long Scraper
		9"	Cotter Key Puller
		7-1/2"	Radiator Hose Hook



859304

## Hook Sets – Heavy Duty

- Nickel Chrome plated finish for corrosion resistance
- Extra long for maximum reach

PROD. NO.	MOD. NO.	Length	Pieces	Contents
<b>859301</b>	JPHS-604	<b>6"</b>	4	Straight Pick
				Bent Hook
				90° Hook
				Compound Hook
<b>859302</b>	JPHS-904	<b>9-3/4"</b>	4	Straight Pick
				Bent Hook
				90° Hook
				Compound Hook



859301

## Open Stock

PROD. NO.	Length	Type	Contained in Set
<b>859305</b>	<b>8-1/2"</b>	1" Scraper	<b>859304</b>
<b>859306</b>	<b>10"</b>	1/2" Scraper	<b>859304</b>
<b>859307</b>	<b>12"</b>	1" Scraper	<b>859304</b>
<b>859308</b>	<b>9"</b>	Cotter Key Puller	<b>859304</b>
<b>859309</b>	<b>7-1/2"</b>	Radiator Hose Hook	<b>859304</b>
<b>859310</b>	<b>6"</b>	Straight Pick	<b>859301</b>
<b>859311</b>	<b>6"</b>	90° Pick	<b>859301</b>
<b>859312</b>	<b>6"</b>	Compound Hook	<b>859301</b>
<b>859313</b>	<b>6"</b>	Bent Hook	<b>859301</b>
<b>859314</b>	<b>9-3/4"</b>	Straight Pick	<b>859302</b>
<b>859315</b>	<b>9-3/4"</b>	90° Pick	<b>859302</b>
<b>859316</b>	<b>9-3/4"</b>	Compound Hook	<b>859302</b>
<b>859317</b>	<b>9-3/4"</b>	Bent Hook	<b>859302</b>



859302



## PRY BARS - HEAVY DUTY

▼ Hand Tools in this section feature:

- Chrome Molybdenum steel for maximum strength
- Super large sizes for the heaviest duty applications
- Extra large bi-material handles provide exceptional grip and comfort and allow the use of both hands for maximum leverage
- "Go-thru" shanks with steel end caps
- Available separately or in 4 piece sets

### 4 PC Cushion Grip Set

779220 / JMPB-4S

- Regular Length: **8" - 45°**, **12" - 45°**, **18" - 45°**, **24" - 45°**



### 4 PC Jumbo Cushion Grip Set

779240 / JHPB-4S

- Jumbo length: **24" - 45°**, **24" - 90°**, **36" - 45°**, **36" - 90°**
- Blow mould case



Extra large bi-material handles

### Cushion Grip Type - Open Stock

PROD. NO.	MOD. NO.	Description	Type	Contained in Set
779221	JMPB-8	8" - 45°	Regular	779220
779222	JMPB-12	12" - 45°	Regular	779220
779223	JMPB-18	18" - 45°	Regular	779220
779224	JMPB-24	24" - 45°	Regular	779220

### Jumbo Cushion Grip Type - Open Stock

PROD. NO.	MOD. NO.	Description	Type	Contained in Set
779241	JHPB-2445	24" - 45° narrow face	Jumbo	779240
779242	JHPB-2490	24" - 90° wide face	Jumbo	779240
779243	JHPB-3645	36" - 45° wide face	Jumbo	779240
779244	JHPB-3600	36" - straight wide face	Jumbo	779240



Chrome Molybdenum Steel is stronger than CrV or Carbon Steel



**4 PC Rolling Head Pry Bar Set** **859211** / JRPB-4S

- Rounded head acts as a fulcrum to provide extra leverage
- Tapered point and round stock ideal for aligning parts through bolt holes
- Heat treated Chrome Vanadium steel for professional use
- Magnetic particle tested to ensure complete material integrity
- Electrostatic powder coat paint protects against corrosion
- Includes: **6, 12, 16, 20"**



**Rolling Head Pry Bars - Open Stock**

PROD. NO.	Length	Contained in Set
<b>859212</b>	<b>6"</b>	<b>859211</b>
<b>859213</b>	<b>12"</b>	<b>859211</b>
<b>859214</b>	<b>16"</b>	<b>859211</b>
<b>859215</b>	<b>20"</b>	<b>859211</b>



Round shank

Rounded head

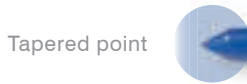

Tapered point



## PRY BARS - SUPER HEAVY DUTY

Indexible Pry Bars are fast becoming a "must have" tool in every mechanic's tool chest. The angle of the claw can be set and locked to provide the best possible leverage in any situation with just a single pry bar. JET takes this new technology to the next level with our exclusive Ratcheting Indexible Pry Bars. These unique tools provide all the benefits of Indexible Pry Bars PLUS the handle can be ratcheted back and forth. This allows the user to gain more leverage as the pried part is loosened without having to reposition the bar. Available only from JET!



### 3 PC POWERCLAW™ Ratcheting Indexible Pry Bar Set - Super Heavy Duty

779271 / JRPB-3S

Unique ratcheting mechanism allows handle to be ratcheted back and forth to gain additional leverage in extremely limited spaces



- Indexible claw locks in up to 8 positions for added torque
- Dual purpose lock button switches between indexed angle setting or ratcheting function
- Chrome Vanadium steel handle with Black Chrome finish for excellent corrosion resistance
- Set contains: **9, 12 and 15"**

#### Ratcheting Indexible Pry Bars - Open Stock

PROD. NO.	MOD. NO.	Length	Contained in Set
779274	JRPB-9	9"	779271
779275	JRPB-12	12"	779271
779276	JRPB-15	15"	779271
779277	JRPB-24	24"	—
779279	JRPB-1830	18 - 30" (Extendible Handle)	



CrMo

Chrome Molybdenum claw and mechanism tested up to **5 times** ANSI standard for fixed head pry bars!



779279  
Extendible Handle

### 2 PC POWERCLAW™ Indexible Pry Bar Set - Super Heavy Duty

779266 / JIPB-2

- Chrome Vanadium steel handle with Black Chrome finish for excellent corrosion resistance
- Set Contents: 1 each **8", 16"**
- Traditional non-ratcheting style



Flush mount locking button minimizes head width for improved access



Indexible claw locks into any of 10 positions for improved leverage in confined spaces

#### Indexible Pry Bars - Open Stock

PROD. NO.	MOD. NO.	Length	Contained in Set
779267	JIPB-8	8"	779266
779268	JIPB-16	16"	779266



CrMo

Chrome Molybdenum claw and mechanism tested up to **5 times** ANSI standard for fixed head pry bars!



# Flashlights



FLASHLIGHTS

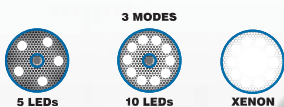
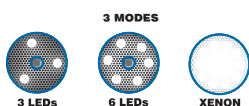

## STRONGARM SERIES

### LED Flashlights - Heavy Duty

- LEDs use less power, burn cool, and last up to 80,000 hours
- Machined aluminum cases anodized inside and out for maximum resistance to corrosion
- O-ring seals prevent water from entering – non-submersible
- Industrial quality rubber sealed switches
- Strongarm LED flashlights are designed to provide a bright view, combined with maximum battery life
- Ideal for lighting work areas and short distances

PROD. NO. MOD. NO.	849804 JLFL-106	849806 JLFL-116	849807 JLFL-130	849809 JLFL-104
<b>Description</b>	<b>6 Light</b> LED Flashlight	<b>16 Light</b> LED Flashlight	<b>30 Light</b> LED Flashlight	LED Flex Light
<b>Battery</b>	Uses 2 AA batteries – Included	Uses 3 C batteries – Not included	Uses 3 D batteries – Not included	Uses 3 AA batteries – Not included
<b>Length</b>	7"	10-1/4"	12-1/2"	33"
<b>Application</b>	Ideal for tool belts	Ideal for tool boxes, glove compartments and many other applications	Ideal for maintenance crews, truckers, emergency personnel and many other applications	Ideal for lighting work areas and small spaces
<b>Standard Accessory</b>	Tool pouch	—	—	—
<b>Features</b>	<b>6 LED lights</b>	<b>16 LED lights</b>	<b>30 LED lights</b>	<b>4 LED Lights</b>

### LED/Xenon Flashlights - Heavy Duty

- High intensity discharge Xenon bulb provides excellent long distance lighting
- Patented technology allows user to change from LED to Xenon light without removing bulb – just press the switch to cycle between full LED, half LED or Xenon bulbs
- Machined aluminum cases are anodized inside and out for corrosion resistance
- Handles and heads knurled for maximum grip
- Virtually shatterproof polycarbonate lenses
- O-ring seals prevent water from entering – non-submersible
- Industrial quality rubber sealed switches

PROD. NO. MOD. NO.	849814 JLXL-106	849815 JLXL-110
<b>Description</b>	<b>6 Light</b> LED/Xenon Flashlight	<b>10 Light</b> LED/Xenon Flashlight
<b>Battery</b>	Uses 3 AAA batteries – Included	Uses 2 D batteries – Not included
<b>Length</b>	5-1/2"	10-1/4"
<b>Features</b>	<ul style="list-style-type: none"> <li>• Change from 3 to 6 LEDs or Xenon bulb with one convenient switch</li> <li>• Convenient hand strap</li> </ul>	<ul style="list-style-type: none"> <li>• Change from 5 to 10 LEDs or Xenon bulb with one convenient switch</li> <li>• Convenient hand strap</li> </ul>
<b>Replacement Bulb</b>	<b>849891</b>	<b>849892</b>



# Master Tool Kits

- MASTER TOOL KIT
- INTERMEDIATE TOOL KIT
- MECHANIC'S STARTER TOOL KIT
- UTILITY TOOL KIT



# 549 PIECE MASTER TOOL KIT

699704 / MTK-549



RECOMMENDED TOOL BOXES

842563

**42"**

pg. **14**

842513



842663

**41"**

pg. **18**

842613



Kit Count	Product Description	Kit Count	Product Description	Kit Count	Product Description
1	10" Bastard Cut Flat File	23	19/64" JET-KUT B&G Premium M2 H.S.S. Jobber Drill Bit	45	1/4" Dr x 7/16" 6 Point Socket
2	8" Smooth Cut Flat File	24	5/16" JET-KUT B&G Premium M2 H.S.S. Jobber Drill Bit	46	1/4" Dr x 1/2" 6 Point Socket
3	10" Smooth Cut Flat File	25	21/64" JET-KUT B&G Premium M2 H.S.S. Jobber Drill Bit	47	1/4" Dr x 3/16" 6 Point Deep Socket
4	8" Bastard Half Round File	26	11/32" JET-KUT B&G Premium M2 H.S.S. Jobber Drill Bit	48	1/4" Dr x 7/32" 6 Point Deep Socket
5	10" Bastard Half Round File	27	23/64" JET-KUT B&G Premium M2 H.S.S. Jobber Drill Bit	49	1/4" Dr x 1/4" 6 Point Deep Socket
6	10" Bastard Cut Mill File	28	3/8" JET-KUT B&G Premium M2 H.S.S. Jobber Drill Bit	50	1/4" Dr x 9/32" 6 Point Deep Socket
7	10" Bastard Cut Round File	29	25/64" JET-KUT B&G Premium M2 H.S.S. Jobber Drill Bit	51	1/4" Dr x 5/16" 6 Point Deep Socket
8	1/16" JET-KUT B&G Premium M2 H.S.S. Jobber Drill Bit	30	13/32" JET-KUT B&G Premium M2 H.S.S. Jobber Drill Bit	52	1/4" Dr x 11/32" 6 Point Deep Socket
9	5/64" JET-KUT B&G Premium M2 H.S.S. Jobber Drill Bit	31	27/64" JET-KUT B&G Premium M2 H.S.S. Jobber Drill Bit	53	1/4" Dr x 3/8" 6 Point Deep Socket
10	3/32" JET-KUT B&G Premium M2 H.S.S. Jobber Drill Bit	32	7/16" JET-KUT B&G Premium M2 H.S.S. Jobber Drill Bit	54	1/4" Dr x 7/16" 6 Point Deep Socket
11	7/64" JET-KUT B&G Premium M2 H.S.S. Jobber Drill Bit	33	29/64" JET-KUT B&G Premium M2 H.S.S. Jobber Drill Bit	55	1/4" Dr x 1/2" 6 Point Deep Socket
12	1/8" JET-KUT B&G Premium M2 H.S.S. Jobber Drill Bit	34	15/32" JET-KUT B&G Premium M2 H.S.S. Jobber Drill Bit	56	1/4" Dr x 4mm 6 Point Socket
13	9/64" JET-KUT B&G Premium M2 H.S.S. Jobber Drill Bit	35	31/64" JET-KUT B&G Premium M2 H.S.S. Jobber Drill Bit	57	1/4" Dr x 5mm 6 Point Socket
14	5/32" JET-KUT B&G Premium M2 H.S.S. Jobber Drill Bit	36	1/2" JET-KUT B&G Premium M2 H.S.S. Jobber Drill Bit	58	1/4" Dr x 6mm 6 Point Socket
15	11/64" JET-KUT B&G Premium M2 H.S.S. Jobber Drill Bit	37	Metal Box with Drill Index	59	1/4" Dr x 7mm 6 Point Socket
16	3/16" JET-KUT B&G Premium M2 H.S.S. Jobber Drill Bit	38	1/4" Dr x 3/16" 6 Point Socket	60	1/4" Dr x 8mm 6 Point Socket
17	13/64" JET-KUT B&G Premium M2 H.S.S. Jobber Drill Bit	39	1/4" Dr x 7/32" 6 Point Socket	61	1/4" Dr x 9mm 6 Point Socket
18	7/32" JET-KUT B&G Premium M2 H.S.S. Jobber Drill Bit	40	1/4" Dr x 1/4" 6 Point Socket	62	1/4" Dr x 10mm 6 Point Socket
19	15/64" JET-KUT B&G Premium M2 H.S.S. Jobber Drill Bit	41	1/4" Dr x 9/32" 6 Point Socket	63	1/4" Dr x 11mm 6 Point Socket
20	1/4" JET-KUT B&G Premium M2 H.S.S. Jobber Drill Bit	42	1/4" Dr x 5/16" 6 Point Socket	64	1/4" Dr x 12mm 6 Point Socket
21	17/64" JET-KUT B&G Premium M2 H.S.S. Jobber Drill Bit	43	1/4" Dr x 11/32" 6 Point Socket	65	1/4" Dr x 4mm 6 Point Deep Socket
22	9/32" JET-KUT B&G Premium M2 H.S.S. Jobber Drill Bit	44	1/4" Dr x 3/8" 6 Point Socket	66	1/4" Dr x 5mm 6 Point Deep Socket

Tool storage not included with kit, see pages 11-33 for tool storage options

# 549 PIECE MASTER TOOL KIT

699704 / MTK-549



Kit Count	Product Description	Kit Count	Product Description	Kit Count	Product Description
67	1/4" Dr x 6mm 6 Point Deep Socket	152	1/2" Dr x 15mm 6 Point Socket	237	3/8" Extra Long Hex Bit Socket
68	1/4" Dr x 7mm 6 Point Deep Socket	153	1/2" Dr x 16mm 6 Point Socket	238	Socket Clip
69	1/4" Dr x 8mm 6 Point Deep Socket	154	1/2" Dr x 17mm 6 Point Socket	239	4mm Extra Long Hex Bit Socket
70	1/4" Dr x 9mm 6 Point Deep Socket	155	1/2" Dr x 18mm 6 Point Socket	240	5mm Extra Long Hex Bit Socket
71	1/4" Dr x 10mm 6 Point Deep Socket	156	1/2" Dr x 19mm 6 Point Socket	241	6mm Extra Long Hex Bit Socket
72	1/4" Dr x 11mm 6 Point Deep Socket	157	1/2" Dr x 21mm 6 Point Socket	242	7mm Extra Long Hex Bit Socket
73	1/4" Dr x 12mm 6 Point Deep Socket	158	1/2" Dr x 22mm 6 Point Socket	243	8mm Extra Long Hex Bit Socket
74	2" Extension	159	1/2" Dr x 23mm 6 Point Socket	244	9mm Extra Long Hex Bit Socket
75	Universal Joint	160	1/2" Dr x 24mm 6 Point Socket	245	10mm Extra Long Hex Bit Socket
76	6" Spinner Handle	161	1/2" Dr x 27mm 6 Point Socket	246	Socket Clip
77	4" Extension	162	1/2" Dr x 30mm 6 Point Socket	247	1/4" Dr x T10 Torx Bit Socket
78	1/4" Ratchet Handle	163	1/2" Dr x 32mm 6 Point Socket	248	1/4" Dr x T15 Torx Bit Socket
79	Blow Mould Case	164	1/2" Dr x 10mm 6 Point Deep Socket	249	1/4" Dr x T20 Torx Bit Socket
80	3/8" Dr x 3/8" 6 Point Socket	165	1/2" Dr x 12mm 6 Point Deep Socket	250	1/4" Dr x T25 Torx Bit Socket
81	3/8" Dr x 7/16" 6 Point Socket	166	1/2" Dr x 13mm 6 Point Deep Socket	251	1/4" Dr x T27 Torx Bit Socket
82	3/8" Dr x 1/2" 6 Point Socket	167	1/2" Dr x 14mm 6 Point Deep Socket	252	1/4" Dr x T30 Torx Bit Socket
83	3/8" Dr x 9/16" 6 Point Socket	168	1/2" Dr x 15mm 6 Point Deep Socket	253	3/8" Dr x T40 Torx Bit Socket
84	3/8" Dr x 5/8" 6 Point Socket	169	1/2" Dr x 16mm 6 Point Deep Socket	254	3/8" Dr x T45 Torx Bit Socket
85	3/8" Dr x 11/16" 6 Point Socket	170	1/2" Dr x 17mm 6 Point Deep Socket	255	3/8" Dr x T47 Torx Bit Socket
86	3/8" Dr x 3/4" 6 Point Socket	171	1/2" Dr x 18mm 6 Point Deep Socket	256	3/8" Dr x T50 Torx Bit Socket
87	3/8" Dr x 3/8" 6 Point Deep Socket	172	1/2" Dr x 19mm 6 Point Deep Socket	257	3/8" Dr x T55 Torx Bit Socket
88	3/8" Dr x 7/16" 6 Point Deep Socket	173	1/2" Dr x 21mm 6 Point Deep Socket	258	Socket Clip
89	3/8" Dr x 1/2" 6 Point Deep Socket	174	2" Extension	259	1/4" Dr - 6" Spinner Handle
90	3/8" Dr x 9/16" 6 Point Deep Socket	175	5" Extension	260	3/8" Dr - 16" Speeder Handle
91	3/8" Dr x 5/8" 6 Point Deep Socket	176	10" Extension	261	3/8" Dr - 5/8" Spark Plug Socket
92	3/8" Dr x 11/16" 6 Point Deep Socket	177	Sliding T Handle	262	3/8" Dr - 13/16" Spark Plug Socket
93	3/8" Dr x 3/4" 6 Point Deep Socket	178	Universal Joint	263	1/2" Dr - 5" Flex Handle
94	3/8" Dr x 13/16" 6 Point Deep Socket	179	High Torque Ratchet	264	1/2" Dr - 16-1/2" Speeder Handle
95	3/8" Dr x 8mm 6 Point Socket	180	Blow Mould Case	265	1/2" Dr - 15" Extension Bar
96	3/8" Dr x 9mm 6 Point Socket	181	3/8" Dr x E4 Torx Socket	266	1/2" Dr - 18" Extension Bar
97	3/8" Dr x 10mm 6 Point Socket	182	3/8" Dr x E5 Torx Socket	267	1/2" Dr - 24" Extension Bar
98	3/8" Dr x 11mm 6 Point Socket	183	3/8" Dr x E6 Torx Socket	268	1/2" Dr - 30" Extension Bar
99	3/8" Dr x 12mm 6 Point Socket	184	3/8" Dr x E7 Torx Socket	269	3/8" Dr - 1-3/4" 2 Way Extension
100	3/8" Dr x 13mm 6 Point Socket	185	3/8" Dr x E8 Torx Socket	270	3/8" Dr - 3" 2 Way Extension
101	3/8" Dr x 14mm 6 Point Socket	186	3/8" Dr x E10 Torx Socket	271	3/8" Dr - 6" 2 Way Extension
102	3/8" Dr x 15mm 6 Point Socket	187	3/8" Dr x E11 Torx Socket	272	3/8" Dr - 10" 2 Way Extension
103	3/8" Dr x 16mm 6 Point Socket	188	3/8" Dr x E12 Torx Socket	273	3/8" Long Combination Wrench
104	3/8" Dr x 17mm 6 Point Socket	189	3/8" Dr x E14 Torx Socket	274	7/16" Long Combination Wrench
105	3/8" Dr x 18mm 6 Point Socket	190	3/8" Dr x E16 Torx Socket	275	1/2" Long Combination Wrench
106	3/8" Dr x 19mm 6 Point Socket	191	3/8" Dr x E18 Torx Socket	276	9/16" Long Combination Wrench
107	3/8" Dr x 8mm 6 Point Deep Socket	192	3/8" Dr x E20 Torx Socket	277	5/8" Long Combination Wrench
108	3/8" Dr x 9mm 6 Point Deep Socket	193	Socket Clip	278	11/16" Long Combination Wrench
109	3/8" Dr x 10mm 6 Point Deep Socket	194	1/2" Dr x 10mm 12 Point Socket	279	3/4" Long Combination Wrench
110	3/8" Dr x 11mm 6 Point Deep Socket	195	1/2" Dr x 11mm 12 Point Socket	280	13/16" Long Combination Wrench
111	3/8" Dr x 12mm 6 Point Deep Socket	196	1/2" Dr x 12mm 12 Point Socket	281	7/8" Long Combination Wrench
112	3/8" Dr x 13mm 6 Point Deep Socket	197	1/2" Dr x 13mm 12 Point Socket	282	15/16" Long Combination Wrench
113	3/8" Dr x 14mm 6 Point Deep Socket	198	1/2" Dr x 14mm 12 Point Socket	283	1" Long Combination Wrench
114	3/8" Dr x 15mm 6 Point Deep Socket	199	1/2" Dr x 15mm 12 Point Socket	284	1-1/16" Long Combination Wrench
115	3/8" Dr x 16mm 6 Point Deep Socket	200	1/2" Dr x 16mm 12 Point Socket	285	1-1/8" Long Combination Wrench
116	3/8" Dr x 17mm 6 Point Deep Socket	201	1/2" Dr x 17mm 12 Point Socket	286	1-1/4" Long Combination Wrench
117	3/8" Dr x 18mm 6 Point Deep Socket	202	1/2" Dr x 18mm 12 Point Socket	287	Terylene Pouch
118	3/8" Dr x 19mm 6 Point Deep Socket	203	1/2" Dr x 19mm 12 Point Socket	288	3/8" Stubby Combination Wrench
119	Flex Handle	204	1/2" Dr x 20mm 12 Point Socket	289	7/16" Stubby Combination Wrench
120	3" Extension	205	1/2" Dr x 21mm 12 Point Socket	290	1/2" Stubby Combination Wrench
121	6" Extension	206	1/2" Dr x 22mm 12 Point Socket	291	9/16" Stubby Combination Wrench
122	Universal Joint	207	1/2" Dr x 24mm 12 Point Socket	292	5/8" Stubby Combination Wrench
123	High Torque Ratchet	208	Socket Clip	293	11/16" Stubby Combination Wrench
124	Blow Mould Case	209	3/8" Dr x 1/8" Hex Key Socket	294	3/4" Stubby Combination Wrench
125	1/2" Dr - 3/8" 6 Point Socket	210	3/8" Dr x 5/32" Hex Key Socket	295	Plastic Rack
126	1/2" Dr x 7/16" 6 Point Socket	211	3/8" Dr x 3/16" Hex Key Socket	296	7mm Long Combination Wrench
127	1/2" Dr x 1/2" 6 Point Socket	212	3/8" Dr x 7/32" Hex Key Socket	297	8mm Long Combination Wrench
128	1/2" Dr x 9/16" 6 Point Socket	213	3/8" Dr x 1/4" Hex Key Socket	298	9mm Long Combination Wrench
129	1/2" Dr x 5/8" 6 Point Socket Wrench	214	3/8" Dr x 5/16" Hex Key Socket	299	10mm Long Combination Wrench
130	1/2" Dr x 11/16" 6 Point Socket Wrench	215	3/8" Dr x 3/8" Hex Key Socket	300	11mm Long Combination Wrench
131	1/2" Dr x 3/4" 6 Point Socket	216	1/2" Dr x 1/2" Hex Key Socket	301	12mm Long Combination Wrench
132	1/2" Dr x 13/16" 6 Point Socket	217	1/2" Dr x 9/16" Hex Key Socket	302	13mm Long Combination Wrench
133	1/2" Dr x 7/8" 6 Point Socket	218	1/2" Dr x 5/8" Hex Key Socket	303	14mm Long Combination Wrench
134	1/2" Dr x 15/16" 6 Point Socket	219	Socket Clip	304	15mm Long Combination Wrench
135	1/2" Dr x 1" 6 Point Socket	220	3/8" Dr x 3mm Hex Key Socket	305	16mm Long Combination Wrench
136	1/2" Dr x 1-1/16" 6 Point Socket	221	3/8" Dr x 4mm Hex Key Socket	306	17mm Long Combination Wrench
137	1/2" Dr x 1-1/8" 6 Point Socket	222	3/8" Dr x 5mm Hex Key Socket	307	18mm Long Combination Wrench
138	1/2" Dr x 1-3/16" 6 Point Socket	223	3/8" Dr x 6mm Hex Key Socket	308	19mm Long Combination Wrench
139	1/2" Dr x 1-1/4" 6 Point Socket	224	3/8" Dr x 7mm Hex Key Socket	309	21mm Long Combination Wrench
140	1/2" Dr x 7/16" 6 Point Deep Socket	225	3/8" Dr x 8mm Hex Key Socket	310	22mm Long Combination Wrench
141	1/2" Dr x 1/2" 6 Point Deep Socket	226	3/8" Dr x 10mm Hex Key Socket	311	24mm Long Combination Wrench
142	1/2" Dr x 9/16" 6 Point Deep Socket	227	1/2" Dr x 12mm Hex Key Socket	312	Terylene Pouch
143	1/2" Dr x 5/8" 6 Point Deep Socket	228	1/2" Dr x 14mm Hex Key Socket	313	10mm Stubby Combination Wrench
144	1/2" Dr x 11/16" 6 Point Deep Socket	229	1/2" Dr x 16mm Hex Key Socket	314	11mm Stubby Combination Wrench
145	1/2" Dr x 3/4" 6 Point Deep Socket	230	Socket Clip	315	12mm Stubby Combination Wrench
146	1/2" Dr x 7/8" 6 Point Deep Socket	231	1/8" Extra Long Hex Bit Socket	316	13mm Stubby Combination Wrench
147	1/2" Dr x 10mm 6 Point Socket	232	5/32" Extra Long Hex Bit Socket	317	14mm Stubby Combination Wrench
148	1/2" Dr x 11mm 6 Point Socket	233	3/16" Extra Long Hex Bit Socket	318	17mm Stubby Combination Wrench
149	1/2" Dr x 12mm 6 Point Socket	234	7/32" Extra Long Hex Bit Socket	319	19mm Stubby Combination Wrench
150	1/2" Dr x 13mm 6 Point Socket	235	1/4" Extra Long Hex Bit Socket	320	Plastic Rack
151	1/2" Dr x 14mm 6 Point Socket	236	5/16" Extra Long Hex Bit Socket	321	1/4" Ratcheting Combination Wrench



# 549 PIECE MASTER TOOL KIT

699704 / MTK-549

Kit Count	Product Description	Kit Count	Product Description	Kit Count	Product Description
322	5/16" Ratcheting Combination Wrench	403	1/8" Hex Bit for Ratcheting Screwdriver	488	T15 Torx Key
323	3/8" Ratcheting Combination Wrench	404	3/16" Hex Bit for Ratcheting Screwdriver	489	T20 Torx Key
324	7/16" Ratcheting Combination Wrench	405	Nut Driver for Ratcheting Screwdriver	490	T25 Torx Key
325	1/2" Ratcheting Combination Wrench	406	Nut Driver for Ratcheting Screwdriver	491	T27 Torx Key
326	9/16" Ratcheting Combination Wrench	407	Nut Driver for Ratcheting Screwdriver	492	T30 Torx Key
327	5/8" Ratcheting Combination Wrench	408	5/16" Slotted Bit for Impact Driver	493	T40 Torx Key
328	11/16" Ratcheting Combination Wrench	409	3/8" Slotted Bit for Impact Driver	494	12" Hacksaw Frame
329	3/4" Ratcheting Combination Wrench	410	#2 Phillips Bit for Impact Driver	495	1/16" Pin Punch
330	13/16" Ratcheting Combination Wrench	411	# 3 Phillips Bit for Impact Driver	496	3/32" Pin Punch
331	7/8" Ratcheting Combination Wrench	412	Driver for Impact Driver	497	1/8" Pin Punch
332	15/16" Ratcheting Combination Wrench	413	Adaptor for Impact Driver	498	5/32" Pin Punch
333	1" Ratcheting Combination Wrench	414	Plastic Case	499	3/16" Pin Punch
334	Plastic Rack	415	3/16" Jumbo Handle Nut Driver	500	1/4" Pin Punch
335	8mm Ratcheting Combination Wrench	416	1/4" Jumbo Handle Nut Driver	501	5/16" Pin Punch
336	9mm Ratcheting Combination Wrench	417	5/16" Jumbo Handle Nut Driver	502	1/16" Solid Punch
337	10mm Ratcheting Combination Wrench	418	11/32" Jumbo Handle Nut Driver	503	1/8" Solid Punch
338	11mm Ratcheting Combination Wrench	419	3/8" Jumbo Handle Nut Driver	504	3/16" Solid Punch
339	12mm Ratcheting Combination Wrench	420	7/16" Jumbo Handle Nut Driver	505	1/4" Solid Punch
340	13mm Ratcheting Combination Wrench	421	1/2" Jumbo Handle Nut Driver	506	5/16" Solid Punch
341	14mm Ratcheting Combination Wrench	422	6" Slip Joint Pliers - Standard Duty	507	5/32" Solid Punch
342	15mm Ratcheting Combination Wrench	423	8" Slip Joint Pliers - Standard Duty	508	1/4" Cold Chisel
343	16mm Ratcheting Combination Wrench	424	9-1/2" Groove Joint Plier - Chrome Vanadium	509	5/16" Cold Chisel
344	17mm Ratcheting Combination Wrench	425	12" Groove Joint Plier - Chrome Vanadium	510	1/2" Cold Chisel
345	18mm Ratcheting Combination Wrench	426	5" Curved Jaw Locking Pliers	511	5/8" Cold Chisel
346	19mm Ratcheting Combination Wrench	427	4" Curved Jaw Locking Pliers	512	3/4" Cold Chisel
347	Plastic Rack	428	10" Curved Jaw Locking Pliers	513	7/8" Cold Chisel
348	18" Aluminum Pipe Wrench	429	6" Long Nose Locking Pliers	514	3/8" Cold Chisel
349	8" Professional Adjustable Wrench	430	9" Long Nose Locking Pliers	515	5/64" Centre Punch
350	12" Professional Adjustable Wrench	431	8" Linesman's Pliers - Chrome Vanadium	516	5/32" Centre Punch
351	3/8" Dr Torque Wrench	432	8" Long Nose Pliers - Chrome Vanadium	517	1/4" Centre Punch
352	1/2" Dr Torque Wrench	433	1" Long Nose Pliers	518	Automatic Centre Punch
353	3/8" x 7/16" Flare Nut Wrench	434	7-1/2" Diagonal Cutter - Chrome Vanadium	519	Terylene Pouch
354	1/2" x 9/16" Flare Nut Wrench	435	6-1/2" Bent Nose Pliers	520	3/32" Roll Pin Punch
355	5/8" x 11/16" Flare Nut Wrench	436	8" Bent Nose Pliers	521	1/8" Roll Pin Pinch
356	10mm x 11mm Flare Nut Wrench	437	11" C-Clamp and Pads	522	5/32" Roll Pin Punch
357	12mm x 13mm Flare Nut Wrench	438	Wire Stripper	523	3/16" Roll Pin Punch
358	15mm x 17mm Flare Nut Wrench	439	Straight Cut Aviation Metal Snips	524	1/4" Roll Pin Punch
359	Phillips: #2 x 1-1/2" Jumbo Handle Screwdriver	440	Telescopic Tube Cutter	525	5/16" Roll Pin Punch
360	Phillips: #1 x 3" Jumbo Handle Screwdriver	441	Mini Tubing Cutter	526	Terylene Pouch
361	Phillips: #2 x 4" Jumbo Handle Screwdriver	442	Screw Feed Tubing Cutter for Flaring Tool Kit	527	25ft Tape Measure
362	Phillips: #3 x 6" Jumbo Handle Screwdriver	443	Flaring Bar for Flaring Tool Kit	528	8" Mechanic's Pry Bar
363	Square: #2 x 1-1/2" Jumbo Handle Screwdriver	444	Yoke for Flaring Tool Kit	529	12" Mechanic's Pry Bar
364	Square: #1 x 4" Jumbo Handle Screwdriver	445	3/16" Flaring Insert for Flaring Tool Kit	530	18" Mechanic's Pry Bar
365	Square: #2 x 5" Jumbo Handle Screwdriver	446	1/4" Flaring Insert for Flaring Tool Kit	531	24" Mechanic's Pry Bar
366	Square: #3 x 6" Jumbo Handle Screwdriver	447	5/16" Flaring Insert for Flaring Tool Kit	532	6" Straight Pick
367	Slot Square Shaft: 1/4 x 1-1/2" Jumbo Handle Screwdriver	448	3/8" Flaring Insert for Flaring Tool Kit	533	6" 90 Pick
368	Slot Square Shaft: 1/4 x 4" Jumbo Handle Screwdriver	449	7/16" Flaring Insert for Flaring Tool Kit	534	6" Compound Hook
369	Slot Square Shaft: 5/16 x 6" Jumbo Handle Screwdriver	450	1/2" Flaring Insert for Flaring Tool Kit	535	6" Bent Hook
370	Slot Square Shaft: 3/8 x 10" Jumbo Handle Screwdriver	451	5/8" Flaring Insert for Flaring Tool Kit	536	8-1/2" Scraper
371	Slot Round Shaft: 3/16 x 3" Jumbo Handle Screwdriver	452	Blow Mould Case	537	10" Scraper
372	Slot Round Shaft: 3/16 x 6" Jumbo Handle Screwdriver	453	8oz Ball Pein Fibreglass Hammer	538	12" Scraper
373	Blow Mould Case	454	16oz Ball Pein Fibreglass Hammer	539	9" Cotter Key Puller
374	2.0 Slot Precision Screwdriver	455	24oz Ball Pein Fibreglass Hammer	540	7-1/2" Radiator Hose Hook
375	3.0 Slot Precision Screwdriver	456	32oz Ball Pein Fibreglass Hammer	541	1-1/4" Chisel Scraper
376	4.0 Slot Precision Screwdriver	457	40oz Ball Pein Fibreglass Hammer	542	1-1/4" Bent Chisel Scraper
377	#00 Phillips Precision Screwdriver	458	2 lb Dead Blow Hammer	543	2" Chisel Scraper
378	#0 Phillips Precision Screwdriver	459	3 lb Dead Blow Hammer	544	Stubby Chisel Scraper
379	#1 Phillips Precision Screwdriver	460	2-1/4 lb Soft Face Dead Blow Hammer	545	1/4"-5/16" Screw Extractor
380	Plastic Case	461	3 lb Drilling Hammer	546	3/8" Screw Extractor
381	T5 Torx Precision Screwdriver	462	3" 2/3 Jaw Gear Puller	547	7/16" Screw Extractor
382	T6 Torx Precision Screwdriver	463	0.05" Long Arm Ball Nose Hex Key	548	1/2"-9/16" Screw Extractor
383	T7 Torx Precision Screwdriver	464	1/16" Long Arm Ball Nose Hex Key	549	5/8" Screw Extractor
384	T8 Torx Precision Screwdriver	465	5/64" Long Arm Ball Nose Hex Key		
385	T9 Torx Precision Screwdriver	466	3/32" Long Arm Ball Nose Hex Key		
386	T10 Torx Precision Screwdriver	467	7/64" Long Arm Ball Nose Hex Key		
387	Plastic Case	468	1/8" Long Arm Ball Nose Hex Key		
388	Ratcheting Screwdriver Handle	469	9/64" Long Arm Ball Nose Hex Key		
389	1/8" Slot Bit for Ratcheting Screwdriver	470	5/32" Long Arm Ball Nose Hex Key		
390	#0 Phillips Bit for Ratcheting Screwdriver	471	3/16" Long Arm Ball Nose Hex Key		
391	3/16" Slot Bit for Ratcheting Screwdriver	472	7/32" Long Arm Ball Nose Hex Key		
392	#1 Phillips Bit for Ratcheting Screwdriver	473	1/4" Long Arm Ball Nose Hex Key		
393	1/4" Slot Bit for Ratcheting Screwdriver	474	5/16" Long Arm Ball Nose Hex Key		
394	#2 Phillips Bit for Ratcheting Screwdriver	475	3/8" Long Arm Ball Nose Hex Key		
395	5/16" Slot Bit for Ratcheting Screwdriver	476	1.5mm Long Arm Ball Nose Hex Key		
396	#3 Phillips Bit for Ratcheting Screwdriver	477	2.0mm Long Arm Ball Nose Hex Key		
397	#1 Square Bit for Ratcheting Screwdriver	478	2.5mm Long Arm Ball Nose Hex Key		
398	#2 Square Bit for Ratcheting Screwdriver	479	3.0mm Long Arm Ball Nose Hex Key		
399	T10 Torx Bit for Ratcheting Screwdriver	480	4.0mm Long Arm Ball Nose Hex Key		
400	T15 Torx Bit for Ratcheting Screwdriver	481	5.0mm Long Arm Ball Nose Hex Key		
401	T20 Torx Bit for Ratcheting Screwdriver	482	6.0mm Long Arm Ball Nose Hex Key		
402	T25 Torx Bit for Ratcheting Screwdriver	483	8.0mm Long Arm Ball Nose Hex Key		
		484	10mm Long Arm Ball Nose Hex Key		
		485	Plastic Rack		
		486	T8 Torx Key		
		487	T10 Torx Key		



# 306 PIECE INTERMEDIATE TOOL KIT

699703 / MIK-306



## RECOMMENDED TOOL BOXES

842563

42"

pg. 14



842663

41"

pg. 18



842553

27"

pg. 13



842653

27"

pg. 16



842513

842613

842503

842604

Kit Count	Product Description	Kit Count	Product Description	Kit Count	Product Description
1	1/16" JET-KUT Black Oxide H.S.S. Jobber Drill Bit	16	19/64" JET-KUT Black Oxide H.S.S. Jobber Drill Bit	31	1/4" Dr x 3/16" 6 Point Socket
2	5/64" JET-KUT Black Oxide H.S.S. Jobber Drill Bit	17	5/16" JET-KUT Black Oxide H.S.S. Jobber Drill Bit	32	1/4" Dr x 7/32" 6 Point Socket
3	3/32" JET-KUT Black Oxide H.S.S. Jobber Drill Bit	18	21/64" JET-KUT Black Oxide H.S.S. Jobber Drill Bit	33	1/4" Dr x 1/4" 6 Point Socket
4	7/64" JET-KUT Black Oxide H.S.S. Jobber Drill Bit	19	11/32" JET-KUT Black Oxide H.S.S. Jobber Drill Bit	34	1/4" Dr x 9/32" 6 Point Socket
5	1/8" JET-KUT Black Oxide H.S.S. Jobber Drill Bit	20	23/64" JET-KUT Black Oxide H.S.S. Jobber Drill Bit	35	1/4" Dr x 5/16" 6 Point Socket
6	9/64" JET-KUT Black Oxide H.S.S. Jobber Drill Bit	21	3/8" JET-KUT Black Oxide H.S.S. Jobber Drill Bit	36	1/4" Dr x 11/32" 6 Point Socket
7	5/32" JET-KUT Black Oxide H.S.S. Jobber Drill Bit	22	25/64" JET-KUT Black Oxide H.S.S. Jobber Drill Bit	37	1/4" Dr x 3/8" 6 Point Socket
8	11/64" JET-KUT Black Oxide H.S.S. Jobber Drill Bit	23	13/32" JET-KUT Black Oxide H.S.S. Jobber Drill Bit	38	1/4" Dr x 7/16" 6 Point Socket
9	3/16" JET-KUT Black Oxide H.S.S. Jobber Drill Bit	24	27/64" JET-KUT Black Oxide H.S.S. Jobber Drill Bit	39	1/4" Dr x 1/2" 6 Point Socket
10	13/64" JET-KUT Black Oxide H.S.S. Jobber Drill Bit	25	7/16" JET-KUT Black Oxide H.S.S. Jobber Drill Bit	40	1/4" Dr x 3/16" 6 Point Deep Socket
11	7/32" JET-KUT Black Oxide H.S.S. Jobber Drill Bit	26	29/64" JET-KUT Black Oxide H.S.S. Jobber Drill Bit	41	1/4" Dr x 7/32" 6 Point Deep Socket
12	15/64" JET-KUT Black Oxide H.S.S. Jobber Drill Bit	27	15/32" JET-KUT Black Oxide H.S.S. Jobber Drill Bit	42	1/4" Dr x 1/4" 6 Point Deep Socket
13	1/4" JET-KUT Black Oxide H.S.S. Jobber Drill Bit	28	31/64" JET-KUT Black Oxide H.S.S. Jobber Drill Bit	43	1/4" Dr x 9/32" 6 Point Deep Socket
14	17/64" JET-KUT Black Oxide H.S.S. Jobber Drill Bit	29	1/2" JET-KUT Black Oxide H.S.S. Jobber Drill Bit	44	1/4" Dr x 5/16" 6 Point Deep Socket
15	9/32" JET-KUT Black Oxide H.S.S. Jobber Drill Bit	30	Metal Box with Drill Index	45	1/4" Dr x 11/32" 6 Point Deep Socket

Tool storage not included with kit, see pages 11-33 for tool storage options



# 306 PIECE INTERMEDIATE TOOL KIT

699703 / MIK-306

Kit Count	Product Description	Kit Count	Product Description	Kit Count	Product Description
46	1/4" Dr x 3/8" 6 Point Deep Socket	133	Socket Clip	220	T6 Torx Precision Screwdriver
47	1/4" Dr x 7/16" 6 Point Deep Socket	134	1/4" Dr x T10 Tamperproof Torx Bit Socket	221	T7 Torx Precision Screwdriver
48	1/4" Dr x 1/2" 6 Point Deep Socket	135	1/4" Dr x T15 Tamperproof Torx Bit Socket	222	T8 Torx Precision Screwdriver
49	1/4" Dr x 4mm 6 Point Socket	136	1/4" Dr x T20 Tamperproof Torx Bit Socket	223	T9 Torx Precision Screwdriver
50	1/4" Dr x 5mm 6 Point Socket	137	1/4" Dr x T25 Tamperproof Torx Bit Socket	224	T10 Torx Precision Screwdriver
51	1/4" Dr x 6mm 6 Point Socket	138	1/4" Dr x T27 Tamperproof Torx Bit Socket	225	Plastic Case
52	1/4" Dr x 7mm 6 Point Socket	139	1/4" Dr x T30 Tamperproof Torx Bit Socket	226	Ratcheting Screwdriver Handle
53	1/4" Dr x 8mm 6 Point Socket	140	3/8" Dr x T40 Tamperproof Torx Bit Socket	227	1/8" Slot Bit for Ratcheting Screwdriver
54	1/4" Dr x 9mm 6 Point Socket	141	3/8" Dr x T45 Tamperproof Torx Bit Socket	228	#0 Phillips Bit for Ratcheting Screwdriver
55	1/4" Dr x 10mm 6 Point Socket	142	3/8" Dr x T50 Tamperproof Torx Bit Socket	229	3/16" Slot Bit for Ratcheting Screwdriver
56	1/4" Dr x 11mm 6 Point Socket	143	3/8" Dr x T55 Tamperproof Torx Bit Socket	230	#1 Phillips Bit for Ratcheting Screwdriver
57	1/4" Dr x 12mm 6 Point Socket	144	Socket Clip	231	1/4" Slot Bit for Ratcheting Screwdriver
58	1/4" Dr x 4mm 6 Point Deep Socket	145	6" Flex Handle	232	#2 Phillips Bit for Ratcheting Screwdriver
59	1/4" Dr x 5mm 6 Point Deep Socket	146	3/8" Dr - 5/8" Spark Plug Socket	233	5/16" Slot Bit for Ratcheting Screwdriver
60	1/4" Dr x 6mm 6 Point Deep Socket	147	3/8" Dr - 13/16" Spark Plug Socket	234	#3 Phillips Bit for Ratcheting Screwdriver
61	1/4" Dr x 7mm 6 Point Deep Socket	148	3/8" Long Combination Wrench	235	#1 Square Bit for Ratcheting Screwdriver
62	1/4" Dr x 8mm 6 Point Deep Socket	149	7/16" Long Combination Wrench	236	#2 Square Bit for Ratcheting Screwdriver
63	1/4" Dr x 9mm 6 Point Deep Socket	150	1/2" Long Combination Wrench	237	T10 Torx Bit for Ratcheting Screwdriver
64	1/4" Dr x 10mm 6 Point Deep Socket	151	9/16" Long Combination Wrench	238	T15 Torx Bit for Ratcheting Screwdriver
65	1/4" Dr x 11mm 6 Point Deep Socket	152	5/8" Long Combination Wrench	239	T20 Torx Bit for Ratcheting Screwdriver
66	1/4" Dr x 12mm 6 Point Deep Socket	153	11/16" Long Combination Wrench	240	T25 Torx Bit for Ratcheting Screwdriver
67	2" Extension	154	3/4" Long Combination Wrench	241	1/8" Hex Bit for Ratcheting Screwdriver
68	Universal Joint	155	13/16" Long Combination Wrench	242	3/16" Hex Bit for Ratcheting Screwdriver
69	6" Spinner Handle	156	7/8" Long Combination Wrench	243	1/4" Nut Driver for Ratcheting Screwdriver
70	4" Extension	157	15/16" Long Combination Wrench	244	5/16" Nut Driver for Ratcheting Screwdriver
71	1/4" Ratchet Handle	158	1" Long Combination Wrench	245	7/16" Nut Driver for Ratcheting Screwdriver
72	Blow Mould Case	159	1-1/16" Long Combination Wrench	246	8" Slip Joint Pliers
73	3/8" Dr x 3/8" 6 Point Socket	160	1-1/8" Long Combination Wrench	247	6-1/2" Long Nose Pliers
74	3/8" Dr x 7/16" 6 Point Socket	161	1-1/4" Long Combination Wrench	248	6-1/2" Diagonal Cutter
75	3/8" Dr x 1/2" 6 Point Socket	162	Terylene Pouch	249	9-1/2" Groove Joint Pliers
76	3/8" Dr x 9/16" 6 Point Socket	163	7mm Long Combination Wrench	250	10" Curved Jaw Locking Pliers
77	3/8" Dr x 5/8" 6 Point Socket	164	8mm Long Combination Wrench	251	9" Multifunction Wire Stripper
78	3/8" Dr x 11/16" 6 Point Socket	165	9mm Long Combination Wrench	252	Straight Cut Aviation Metal Snips
79	3/8" Dr x 3/4" 6 Point Socket	166	10mm Long Combination Wrench	253	Telescopic Tube Cutter
80	3/8" Dr x 3/8" 6 Point Deep Socket	167	11mm Long Combination Wrench	254	1lb Rubber Mallet
81	3/8" Dr x 7/16 6 Point Deep Socket	168	12mm Long Combination Wrench	255	1.5mm Short Arm Hex Key
82	3/8" Dr x 1/2" 6 Point Deep Socket	169	13mm Long Combination Wrench	256	2.0mm Short Arm Hex Key
83	3/8" Dr x 9/16" 6 Point Deep Socket	170	14mm Long Combination Wrench	257	2.5mm Short Arm Hex Key
84	3/8" Dr x 5/8" 6 Point Deep Socket	171	15mm Long Combination Wrench	258	3.0mm Short Arm Hex Key
85	3/8" Dr x 11/16" 6 Point Deep Socket	172	16mm Long Combination Wrench	259	4.0mm Short Arm Hex Key
86	3/8" Dr x 3/4" 6 Point Deep Socket	173	17mm Long Combination Wrench	260	4.5mm Short Arm Hex Key
87	3/8" Dr x 13/16" 6 Point Deep Socket	174	18mm Long Combination Wrench	261	5.0mm Short Arm Hex Key
88	3/8" Dr x 8mm 6 Point Socket	175	19mm Long Combination Wrench	262	5.5mm Short Arm Hex Key
89	3/8" Dr x 9mm 6 Point Socket	176	21mm Long Combination Wrench	263	6.0mm Short Arm Hex Key
90	3/8" Dr x 10mm 6 Point Socket	177	22mm Long Combination Wrench	264	7.0mm Short Arm Hex Key
91	3/8" Dr x 11mm 6 Point Socket	178	24mm Long Combination Wrench	265	8.0mm Short Arm Hex Key
92	3/8" Dr x 12mm 6 Point Socket	179	Terylene Pouch	266	9.0mm Short Arm Hex Key
93	3/8" Dr x 13mm 6 Point Socket	180	8mm Ratcheting Combination Wrench	267	10.0mm Short Arm Hex Key
94	3/8" Dr x 14mm 6 Point Socket	181	10mm Ratcheting Combination Wrench	268	1/16" Long Arm Hex Key
95	3/8" Dr x 15mm 6 Point Socket	182	12mm Ratcheting Combination Wrench	269	5/64" Long Arm Hex Key
96	3/8" Dr x 16mm 6 Point Socket	183	13mm Ratcheting Combination Wrench	270	3/32" Long Arm Hex Key
97	3/8" Dr x 17mm 6 Point Socket	184	14mm Ratcheting Combination Wrench	271	7/64" Long Arm Hex Key
98	3/8" Dr x 18mm 6 Point Socket	185	15mm Ratcheting Combination Wrench	272	1/8" Long Arm Hex Key
99	3/8" Dr x 19mm 6 Point Socket	186	18mm Ratcheting Combination Wrench	273	9/64" Long Arm Hex Key
100	3/8" Dr x 8mm 6 Point Deep Socket	187	Plastic Rack	274	5/32" Long Arm Hex Key
101	3/8" Dr x 9mm 6 Point Deep Socket	188	5/16" Ratcheting Combination Wrench	275	3/16" Long Arm Hex Key
102	3/8" Dr x 10mm 6 Point Deep Socket	189	3/8" Ratcheting Combination Wrench	276	7/32" Long Arm Hex Key
103	3/8" Dr x 11mm 6 Point Deep Socket	190	7/16" Ratcheting Combination Wrench	277	1/4" Long Arm Hex Key
104	3/8" Dr x 12mm 6 Point Deep Socket	191	1/2" Ratcheting Combination Wrench	278	5/16" Long Arm Hex Key
105	3/8" Dr x 13mm 6 Point Deep Socket	192	9/16" Ratcheting Combination Wrench	279	3/8" Long Arm Hex Key
106	3/8" Dr x 14mm 6 Point Deep Socket	193	5/8" Ratcheting Combination Wrench	280	Plastic Rack
107	3/8" Dr x 15mm 6 Point Deep Socket	194	11/16" Ratcheting Combination Wrench	281	1/8" Pin Punch
108	3/8" Dr x 16mm 6 Point Deep Socket	195	3/4" Ratcheting Combination Wrench	282	3/16" Pin Punch
109	3/8" Dr x 17mm 6 Point Deep Socket	196	Plastic Rack	283	1/4" Pin Punch
110	3/8" Dr x 18mm 6 Point Deep Socket	197	10" Professional Adjustable Wrench	284	3/16" Solid Punch
111	3/8" Dr x 19mm 6 Point Deep Socket	198	T10 x 4" Torx Mechanic's Screwdriver	285	1/2" Cold Chisel
112	Flex Handle	199	T15 x 4" Torx Mechanic's Screwdriver	286	5/8" Cold Chisel
113	3" Extension	200	T20 x 4" Torx Mechanic's Screwdriver	287	3/4" Cold Chisel
114	6" Extension	201	T25 x 4" Torx Mechanic's Screwdriver	288	5/32" Centre Punch
115	Universal Joint	202	T27 x 4" Torx Mechanic's Screwdriver	289	Terylene Pouch
116	High Torque Ratchet	203	T30 x 4" Torx Mechanic's Screwdriver	290	16ft Tape Measure
117	Blow Mould Case	204	Slot: 1/4 x 1-1/2" Mechanic's Screwdriver	291	8" Mechanic's Pry Bar
118	1/8" Hex Bit Socket	205	Slot: 1/4 x 4" Mechanic's Screwdriver	292	12" Mechanic's Pry Bar
119	5/32" Hex Bit Socket	206	Slot: 5/16 x 6" Mechanic's Screwdriver	293	18" Mechanic's Pry Bar
120	3/16" Hex Bit Socket	207	Slot: 3/8 x 10" Mechanic's Screwdriver	294	24" Mechanic's Pry Bar
121	7/32" Hex Bit Socket	208	Phillips: #1 x 3" Mechanic's Screwdriver	295	1" Short Scraper
122	1/4" Hex Bit Socket	209	Phillips: #2 x 1-1/2" Mechanic's Screwdriver	296	Parts Cleaning Brush
123	5/16" Hex Bit Socket	210	Phillips: #2 x 4" Mechanic's Screwdriver	297	6-12 Volt Circuit Tester
124	3/8" Hex Bit Socket	211	Blow Mould Case	298	Long Telescoping Magnet
125	Socket Clip	212	2.0 Slot Precision Screwdriver	299	Mechanic's Stethoscope
126	3/8" Dr x 3mm Hex Bit Socket	213	3.0 Slot Precision Screwdriver	300	1/8" - 1/4" Screw Extractor
127	3/8" Dr x 4mm Hex Bit Socket	214	4.0 Slot Precision Screwdriver	301	1/4" - 5/16" Screw Extractor
128	3/8" Dr x 5mm Hex Bit Socket	215	#00 Phillips Precision Screwdriver	302	5/16" - 7/16" Screw Extractor
129	3/8" Dr x 6mm Hex Bit Socket	216	#0 Phillips Precision Screwdriver	303	7/16" - 9/16" Screw Extractor
130	3/8" Dr x 7mm Hex Bit Socket	217	#1 Phillips Precision Screwdriver	304	9/16" - 3/4" Screw Extractor
131	3/8" Dr x 8mm Hex Bit Socket	218	Plastic Case	305	Tie Rod End Puller
132	3/8" Dr x 10mm Hex Bit Socket	219	T5 Torx Precision Screwdriver	306	4-Battery Post and Terminal Clean

# 211 PIECE MECHANIC'S STARTER TOOL KIT

699702 / STK-211



842652  
Included with Kit



# 211 PIECE MECHANIC'S STARTER TOOL KIT

699702 / STK-211

Kit Count	Product Description	Kit Count	Product Description	Kit Count	Product Description
1	1/4" Dr x 3/16" 6 Point Socket	72	3/8" Dr x 10mm 6 Point Deep Socket	143	Slot Round Shaft: 3/16 x 3" Jumbo Handle Screwdriver
2	1/4" Dr x 7/32" 6 Point Socket	73	3/8" Dr x 11mm 6 Point Deep Socket	144	Slot Round Shaft: 3/16 x 6" Jumbo Handle Screwdriver
3	1/4" Dr x 1/4" 6 Point Socket	74	3/8" Dr x 12mm 6 Point Deep Socket	145	Blow Mould Case
4	1/4" Dr x 9/32" 6 Point Socket	75	3/8" Dr x 13mm 6 Point Deep Socket	146	T10 x 4" Jumbo Handle Torx Screwdriver
5	1/4" Dr x 5/16" 6 Point Socket	76	3/8" Dr x 14mm 6 Point Deep Socket	147	T15 x 4" Jumbo Handle Torx Screwdriver
6	1/4" Dr x 11/32" 6 Point Socket	77	3/8" Dr x 15mm 6 Point Deep Socket	148	T20 x 4" Jumbo Handle Torx Screwdriver
7	1/4" Dr x 3/8" 6 Point Socket	78	3/8" Dr x 16mm 6 Point Deep Socket	149	T25 x 4" Jumbo Handle Torx Screwdriver
8	1/4" Dr x 7/16" 6 Point Socket	79	3/8" Dr x 17mm 6 Point Deep Socket	150	T27 x 4" Jumbo Handle Torx Screwdriver
9	1/4" Dr x 1/2" 6 Point Socket	80	3/8" Dr x 18mm 6 Point Deep Socket	151	T30 x 4" Jumbo Handle Torx Screwdriver
10	1/4" Dr x 3/16" 6 Point Deep Socket	81	3/8" Dr x 19mm 6 Point Deep Socket	152	Terylene Pouch
11	1/4" Dr x 7/32" 6 Point Deep Socket	82	Flex Handle	153	8" Slip Joint Pliers
12	1/4" Dr x 1/4" 6 Point Deep Socket	83	3" Extension	154	8" Lineman's Pliers
13	1/4" Dr x 9/32" 6 Point Deep Socket	84	6" Extension	155	8" Long Nose Pliers
14	1/4" Dr x 5/16" 6 Point Deep Socket	85	Universal Joint	156	7-1/2" Diagonal Cutters
15	1/4" Dr x 11/32" 6 Point Deep Socket	86	High Torque Ratchet	157	8" Bent Nose Pliers
16	1/4" Dr x 3/8" 6 Point Deep Socket	87	Blow Mould Case	158	Terylene Pouch
17	1/4" Dr x 7/16" 6 Point Deep Socket	88	3/8" Female - 1/4" Male Adaptor	159	6" External Straight Tip for Snap Ring Pliers
18	1/4" Dr x 1/2" 6 Point Deep Socket	89	3/8" Female - 1/2" Male Adaptor	160	6" External Bent Tip for Snap Ring Pliers
19	1/4" Dr x 4mm 6 Point Socket	90	1/4" Raised Panel Combination Wrench	161	6" Internal Straight Tip for Snap Ring Pliers
20	1/4" Dr x 5mm 6 Point Socket	91	5/16" Raised Panel Combination Wrench	162	6" Internal Bent Tip for Snap Ring Pliers
21	1/4" Dr x 6mm 6 Point Socket	92	3/8" Raised Panel Combination Wrench	163	Handle for Snap Ring Pliers
22	1/4" Dr x 7mm 6 Point Socket	93	7/16" Raised Panel Combination Wrench	164	10" Curved Jaw Locking Pliers
23	1/4" Dr x 8mm 6 Point Socket	94	1/2" Raised Panel Combination Wrench	165	9" Multifunction Wire Stripper
24	1/4" Dr x 9mm 6 Point Socket	95	9/16" Raised Panel Combination Wrench	166	Quick Adjustable Tubing Cutter
25	1/4" Dr x 10mm 6 Point Socket	96	5/8" Raised Panel Combination Wrench	167	16 oz Hickory Handle Ball Pein Hammer
26	1/4" Dr x 11mm 6 Point Socket	97	11/16" Raised Panel Combination Wrench	168	1.5mm Short Arm Hex Key
27	1/4" Dr x 12mm 6 Point Socket	98	3/4" Raised Panel Combination Wrench	169	2.0mm Short Arm Hex Key
28	1/4" Dr x 4mm 6 Point Deep Socket	99	13/16" Raised Panel Combination Wrench	170	2.5mm Short Arm Hex Key
29	1/4" Dr x 5mm 6 Point Deep Socket	100	7/8" Raised Panel Combination Wrench	171	3.0mm Short Arm Hex Key
30	1/4" Dr x 6mm 6 Point Deep Socket	101	15/16" Raised Panel Combination Wrench	172	4.0mm Short Arm Hex Key
31	1/4" Dr x 7mm 6 Point Deep Socket	102	1" Raised Panel Combination Wrench	173	4.5mm Short Arm Hex Key
32	1/4" Dr x 8mm 6 Point Deep Socket	103	1-1/16" Raised Panel Combination Wrench	174	5.0mm Short Arm Hex Key
33	1/4" Dr x 9mm 6 Point Deep Socket	104	1-1/8" Raised Panel Combination Wrench	175	5.5mm Short Arm Hex Key
34	1/4" Dr x 10mm 6 Point Deep Socket	105	1-1/4" Raised Panel Combination Wrench	176	6.0mm Short Arm Hex Key
35	1/4" Dr x 11mm 6 Point Deep Socket	106	Terylene Pouch	177	7.0mm Short Arm Hex Key
36	1/4" Dr x 12mm 6 Point Deep Socket	107	7mm Raised Panel Combination Wrench	178	8.0mm Short Arm Hex Key
37	2" Extension	108	8mm Raised Panel Combination Wrench	179	9.0mm Short Arm Hex Key
38	Universal Joint	109	9mm Raised Panel Combination Wrench	180	10.0mm Short Arm Hex Key
39	6" Spinner Handle	110	10mm Raised Panel Combination Wrench	181	1/16" Long Arm Hex Key
40	4" Extension	111	11mm Raised Panel Combination Wrench	182	5/64" Long Arm Hex Key
41	1/4" Ratchet Handle	112	12mm Raised Panel Combination Wrench	183	3/32" Long Arm Hex Key
42	Blow Mould Case	113	13mm Raised Panel Combination Wrench	184	7/64" Long Arm Hex Key
43	3/8" Dr x 3/8" 6 Point Socket	114	14mm Raised Panel Combination Wrench	185	1/8" Long Arm Hex Key
44	3/8" Dr x 7/16" 6 Point Socket	115	15mm Raised Panel Combination Wrench	186	9/64" Long Arm Hex Key
45	3/8" Dr x 1/2" 6 Point Socket	116	16mm Raised Panel Combination Wrench	187	5/32" Long Arm Hex Key
46	3/8" Dr x 9/16" 6 Point Socket	117	17mm Raised Panel Combination Wrench	188	3/16" Long Arm Hex Key
47	3/8" Dr x 5/8" 6 Point Socket	118	18mm Raised Panel Combination Wrench	189	7/32" Long Arm Hex Key
48	3/8" Dr x 11/16" 6 Point Socket	119	19mm Raised Panel Combination Wrench	190	1/4" Long Arm Hex Key
49	3/8" Dr x 3/4" 6 Point Socket	120	20mm Raised Panel Combination Wrench	191	5/16" Long Arm Hex Key
50	3/8" Dr x 3/8" 6 Point Deep Socket	121	21mm Raised Panel Combination Wrench	192	3/8" Long Arm Hex Key
51	3/8" Dr x 7/16 6 Point Deep Socket	122	22mm Raised Panel Combination Wrench	193	Plastic Rack
52	3/8" Dr x 1/2" 6 Point Deep Socket	123	23mm Raised Panel Combination Wrench	194	12" Hacksaw Frame
53	3/8" Dr x 9/16" 6 Point Deep Socket	124	24mm Raised Panel Combination Wrench	195	1/8" Pin Punch
54	3/8" Dr x 5/8" 6 Point Deep Socket	125	26mm Raised Panel Combination Wrench	196	3/16" Pin Punch
55	3/8" Dr x 11/16" 6 Point Deep Socket	126	27mm Raised Panel Combination Wrench	197	1/4" Pin Punch
56	3/8" Dr x 3/4" 6 Point Deep Socket	127	30mm Raised Panel Combination Wrench	198	3/16" Solid Punch
57	3/8" Dr x 13/16" 6 Point Deep Socket	128	32mm Raised Panel Combination Wrench	199	1/2" Cold Chisel
58	3/8" Dr x 8mm 6 Point Socket	129	Terylene Pouch	200	5/8" Cold Chisel
59	3/8" Dr x 9mm 6 Point Socket	130	10" Professional Adjustable Wrench	201	3/4" Cold Chisel
60	3/8" Dr x 10mm 6 Point Socket	131	Phillips: #2 x 1-1/2" Jumbo Handle Screwdriver	202	5/32" Centre Punch
61	3/8" Dr x 11mm 6 Point Socket	132	Phillips: #1 x 3" Jumbo Handle Screwdriver	203	Terylene Pouch
62	3/8" Dr x 12mm 6 Point Socket	133	Phillips: #2 x 4" Jumbo Handle Screwdriver	204	18" Pry Bar
63	3/8" Dr x 13mm 6 Point Socket	134	Phillips: #3 x 6" Jumbo Handle Screwdriver	205	26" x 12" 6 Drawer B&G Series Mechanic's Chest
64	3/8" Dr x 14mm 6 Point Socket	135	Square: #2 x 1-1/2" Jumbo Handle Screwdriver	206	1" Short Scraper
65	3/8" Dr x 15mm 6 Point Socket	136	Square: #1 x 4" Jumbo Handle Screwdriver	207	Battery Post and Terminal Cleaner
66	3/8" Dr x 16mm 6 Point Socket	137	Square: #2 x 5" Jumbo Handle Screwdriver	208	6-12 Volt Circuit Tester
67	3/8" Dr x 17mm 6 Point Socket	138	Square: #3 x 6" Jumbo Handle Screwdriver	209	Long Telescoping Magnet
68	3/8" Dr x 18mm 6 Point Socket	139	Slot Square Shaft: 1/4 x 1-1/2" Jumbo Handle Screwdriver	210	Strap Filter Wrench
69	3/8" Dr x 19mm 6 Point Socket	140	Slot Square Shaft: 1/4 x 4" Jumbo Handle Screwdriver	211	Universal Master Feeler Gauge
70	3/8" Dr x 8mm 6 Point Deep Socket	141	Slot Square Shaft: 5/16 x 6" Jumbo Handle Screwdriver		
71	3/8" Dr x 9mm 6 Point Deep Socket	142	Slot Square Shaft: 3/8 x 10" Jumbo Handle Screwdriver		

# 131 PIECE UTILITY TOOL KIT

699701 / UTK-131



842124  
Included with Kit

Kit Count	Product Description
1	1/16" JET-KUT Black Oxide H.S.S. Jobber Drill Bit
2	5/64" JET-KUT Black Oxide H.S.S. Jobber Drill Bit
3	3/32" JET-KUT Black Oxide H.S.S. Jobber Drill Bit
4	7/64" JET-KUT Black Oxide H.S.S. Jobber Drill Bit
5	1/8" JET-KUT Black Oxide H.S.S. Jobber Drill Bit
6	9/64" JET-KUT Black Oxide H.S.S. Jobber Drill Bit
7	5/32" JET-KUT Black Oxide H.S.S. Jobber Drill Bit
8	11/64" JET-KUT Black Oxide H.S.S. Jobber Drill Bit
9	3/16" JET-KUT Black Oxide H.S.S. Jobber Drill Bit
10	13/64" JET-KUT Black Oxide H.S.S. Jobber Drill Bit
11	7/32" JET-KUT Black Oxide H.S.S. Jobber Drill Bit
12	15/64" JET-KUT Black Oxide H.S.S. Jobber Drill Bit
13	1/4" JET-KUT Black Oxide H.S.S. Jobber Drill Bit
14	17/64" JET-KUT Black Oxide H.S.S. Jobber Drill Bit
15	9/32" JET-KUT Black Oxide H.S.S. Jobber Drill Bit
16	19/64" JET-KUT Black Oxide H.S.S. Jobber Drill Bit
17	5/16" JET-KUT Black Oxide H.S.S. Jobber Drill Bit
18	21/64" JET-KUT Black Oxide H.S.S. Jobber Drill Bit
19	11/32" JET-KUT Black Oxide H.S.S. Jobber Drill Bit
20	23/64" JET-KUT Black Oxide H.S.S. Jobber Drill Bit
21	3/8" JET-KUT Black Oxide H.S.S. Jobber Drill Bit
22	25/64" JET-KUT Black Oxide H.S.S. Jobber Drill Bit
23	13/32" JET-KUT Black Oxide H.S.S. Jobber Drill Bit
24	27/64" JET-KUT Black Oxide H.S.S. Jobber Drill Bit
25	7/16" JET-KUT Black Oxide H.S.S. Jobber Drill Bit
26	29/64" JET-KUT Black Oxide H.S.S. Jobber Drill Bit
27	15/32" JET-KUT Black Oxide H.S.S. Jobber Drill Bit
28	31/64" JET-KUT Black Oxide H.S.S. Jobber Drill Bit
29	1/2" JET-KUT Black Oxide H.S.S. Jobber Drill Bit
30	Metal Box with Drill Index
31	1/4" Dr x 3/16" 6 Point Socket
32	1/4" Dr x 7/32" 6 Point Socket
33	1/4" Dr x 1/4" 6 Point Socket
34	1/4" Dr x 9/32" 6 Point Socket
35	1/4" Dr x 5/16" 6 Point Socket
36	1/4" Dr x 11/32" 6 Point Socket
37	1/4" Dr x 3/8" 6 Point Socket
38	1/4" Dr x 7/16" 6 Point Socket

Kit Count	Product Description
39	1/4" Dr x 1/2" 6 Point Socket
40	1/4" Dr x 3/16" 6 Point Deep Socket
41	1/4" Dr x 7/32" 6 Point Deep Socket
42	1/4" Dr x 1/4" 6 Point Deep Socket
43	1/4" Dr x 9/32" 6 Point Deep Socket
44	1/4" Dr x 5/16" 6 Point Deep Socket
45	1/4" Dr x 11/32" 6 Point Deep Socket
46	1/4" Dr x 3/8" 6 Point Deep Socket
47	1/4" Dr x 7/16" 6 Point Deep Socket
48	1/4" Dr x 1/2" 6 Point Deep Socket
49	2" Extension
50	6" Extension
51	Universal Joint
52	6" Spinner Handle
53	1/4" Oval Head Ratchet
54	Metal Case
55	3/8" Dr x 3/8" 6 Point Socket
56	3/8" Dr x 7/16" 6 Point Socket
57	3/8" Dr x 1/2" 6 Point Socket
58	3/8" Dr x 9/16" 6 Point Socket
59	3/8" Dr x 5/8" 6 Point Socket
60	3/8" Dr x 11/16" 6 Point Socket
61	3/8" Dr x 3/4" 6 Point Socket
62	3/8" Dr x 3/8" 6 Point Deep Socket
63	3/8" Dr x 7/16 6 Point Deep Socket
64	3/8" Dr x 1/2" 6 Point Deep Socket
65	3/8" Dr x 9/16" 6 Point Deep Socket
66	3/8" Dr x 5/8" 6 Point Deep Socket
67	3/8" Dr x 11/16" 6 Point Deep Socket
68	3/8" Dr x 3/4" 6 Point Deep Socket
69	3/8" Dr x 13/16" 6 Point Deep Socket
70	Flex Handle
71	3" Extension
72	6" Extension
73	Universal Joint
74	3/8" Oval Head Ratchet
75	Blow Mould Case
76	3/8" Dr x 5/8" Spark Plug Socket

Kit Count	Product Description
77	3/8" Raised Panel Combination Wrench
78	7/16" Raised Panel Combination Wrench
79	1/2" Raised Panel Combination Wrench
80	9/16" Raised Panel Combination Wrench
81	5/8" Raised Panel Combination Wrench
82	11/16" Raised Panel Combination Wrench
83	3/4" Raised Panel Combination Wrench
84	13/16" Raised Panel Combination Wrench
85	7/8" Raised Panel Combination Wrench
86	15/16" Raised Panel Combination Wrench
87	1" Raised Panel Combination Wrench
88	Terylene Pouch
89	10" Professional Adjustable Wrench
90	4" Jumbo Handle Screwdriver
91	6" Jumbo Handle Screwdriver
92	#1 Jumbo Handle Phillips Screwdriver
93	#2 Jumbo Handle Phillips Screwdriver
94	#1 Square Jumbo Handle Screwdriver
95	#2 Square Jumbo Handle Screwdriver
96	Plastic Rack
97	8" Slip Joint Pliers
98	8" Lineman's Pliers
99	8" Long Nose Pliers
100	7-1/2" Diagonal Cutters
101	8" Bent Nose Pliers
102	Terylene Pouch
103	9-1/2" Groove Joint Pliers
104	10" Curved Jaw Locking Pliers
105	16 Oz Fibreglass Claw Hammer
106	0.05" Short Arm Hex Key
107	1/16" Short Arm Hex Key
108	5/64" Short Arm Hex Key
109	3/32" Short Arm Hex Key
110	7/64" Short Arm Hex Key
111	1/8" Short Arm Hex Key
112	9/64" Short Arm Hex Key
113	5/32" Short Arm Hex Key
114	3/16" Short Arm Hex Key
115	7/32" Short Arm Hex Key
116	1/4" Short Arm Hex Key
117	5/16" Short Arm Hex Key
118	3/8" Short Arm Hex Key
119	Plastic Rack
120	1/8" Pin Punch
121	3/16" Pin Punch
122	1/4" Pin Punch
123	3/16" Solid Punch
124	1/2" Cold Chisel
125	5/8" Cold Chisel
126	3/4" Cold Chisel
127	5/32" Centre Punch
128	Terylene Pouch
129	16ft Tape Measure
130	Telescopic Pick Up Tool
131	21" 3 Drawer Steel Hand Tool Box

**JET**



[www.jetequipment.com](http://www.jetequipment.com)



## Merchandisers

LUBRICATION  
HAND TOOLS  
SPECIALTY AUTO  
POP DISPLAYS



NEW HAND TOOLS DISPLAY MERCHANDISERS



**HAMMER  
DISPLAY HOOK**  
890927



**PUMP DISPLAY RACK**  
890679



**21 PC LUBRICATION &  
FLUID TRANSFER**  
890481



**27 PC LUBRICATION  
& FLUID TRANSFER**  
890482



**NEW**



**49 PC LUBRICATION  
AND FLUID TRANSFER**

890483

**NEW**



**ERGONOMIC SCREWDRIVER  
DISPLAY**

890483



# HAND TOOLS DISPLAY MERCHANDISERS



**SAE CHROME SOCKETS**  
1/4", 3/8" & 1/2" DR  
890181



**METRIC CHROME SOCKETS**  
1/4", 3/8" & 1/2" DR  
890182



**1/2" DRIVE IMPACT SOCKETS**  
890187



**HEX AND TORX® SOCKETS**  
890184



**3/4" DR IMPACT SOCKETS**  
890455



**3/4" DR DEEP IMPACT SOCKETS**  
890456



**12 PT. CHROME SOCKETS**  
1/4" & 3/8"  
890444



**HEX TOOLS**  
890428



**3/4" DR SOCKET TOOLS**  
890195



**SOCKET ACCESSORIES**  
890430



**HEX KEYS**  
890429



**HEX AND TORX® BITS**  
890457



**COMBINATION WRENCHES**

890177



**COMBINATION RATCHETING WRENCHES**

890426



**LONG PATTERN COMBINATION WRENCHES**

890407



**ADJUSTABLE WRENCHES**

890174



**CHROME NICKEL PLIERS DISPLAY**

890471



**CHROME VANADIUM PLIERS DISPLAY**

890472



**LOCKING PLIERS**

890427



**ELECTRICAL TOOLS**

890442



**AVIATION SNIPS**

890446



**BOLT CUTTERS**

890175



# HAND TOOLS DISPLAY MERCHANDISERS



**JUMBO HANDLE  
SCREWDRIVERS**

890171



**SCREWDRIVERS**

**TORQUE DRIVE**

890172



**JUMBO HANDLE  
NUT DRIVERS**

890173

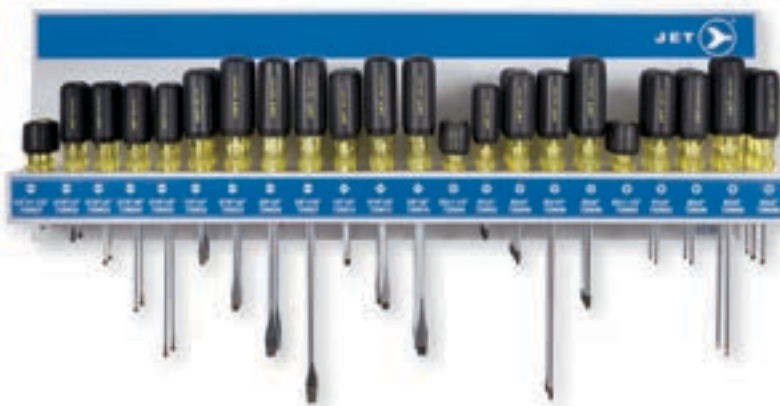

**CUSHION GRIP SCREWDRIVERS**

890468



**CUSHION GRIP NUT DRIVERS**

890469

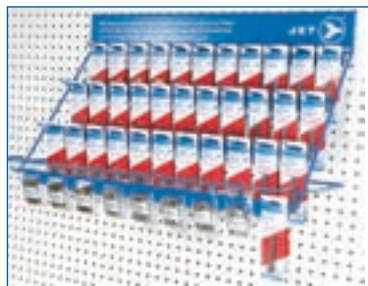

**INSERT BITS**

890453



**POWER BITS**

890454

# HAND TOOLS DISPLAY MERCHANDISERS



**STAPLERS AND TACKERS**  
890443



**PUNCHES AND CHISELS**  
890445



**PIPE CUTTERS**  
890447



**PRY BARS**  
890451



**STRIKING TOOLS**  
890690



**UNIVERSAL ROLLING  
DISPLAY RACK**  
890698



**INDESTRUCTIBLE HANDLE  
STRIKING TOOLS**  
890458



**CLAMP RACK**  
890648



# SPECIALTY AUTO DISPLAY MERCHANDISERS



## LOCKNUT SOCKETS

HT8751



## CHROME TACHOMETERS & GAUGES

HT8754



## CLASSIC TACHOMETER & GAUGES

HT8756



## ALL-WEATHER HEAVY DUTY TACHOMETER & GAUGES

HT8758



## TIRE SERVICE TOOLS

HT8760



## SPECIALTY TOOL WALL DISPLAY

HT8560



**16" PLASTIC HAND TOOL BOX**  
 QTY 14  
 842142



**19" PLASTIC HAND TOOL BOX**  
 QTY 12  
 842143



**22" PLASTIC HAND TOOL BOX**  
 QTY 10  
 842144



**16' S.A.E./METRIC TAPE MEASURE**  
 QTY 6  
 775921



**25' S.A.E. TAPE MEASURE**  
 QTY 12  
 775928



**25' S.A.E./METRIC TAPE MEASURE**  
 QTY 12  
 775929



**12-IN-1 RATCHETING BOX END WRENCH SET**  
 QTY 10  
 700391



**3/8" TWIST DRIVE RATCHET**  
 QTY 6  
 671923



**1/2" TWIST DRIVE RATCHET**  
 QTY 6  
 672923



**6-IN-1 CUSHION GRIP  
MULTI-BIT SCREWDRIVER**

QTY 6  
720533



**10-IN-1 CUSHION GRIP  
MULTI-BIT SCREWDRIVER**

QTY 6  
720534



**5-IN-1 CUSHION GRIP STUBBY  
MULTI-BIT SCREWDRIVER**

QTY 6  
720531



**1/4", 3/8" & 1/2" DRIVE  
SWIVEL HEAD RATCHET**

QTY 9  
890512



**19 PC  
RATCHETING SCREWDRIVER**

QTY 12  
720590



**15 PC TWIN DRIVE  
RATCHETING SCREWDRIVER**

QTY 6  
720537



**CONVERTIBLE PISTOL  
GRIP RATCHETING  
SCREWDRIVER**

QTY 12  
720551



**STUBBY RATCHETING  
SCREWDRIVER**

QTY 12  
720552



**T-HANDLE RATCHETING  
SCREWDRIVER**

QTY 12  
720556





## SPECIALTY AUTO POP DISPLAYS



### MINI-SCRAPER

QTY 30  
H3237DA



### 15-IN-1 SCREWDRIVER

QTY 6  
H3400



### TIRE GAUGE – PENCIL TYPE

QTY 24  
H3262



### TIRE GAUGE – DIAL TYPE 10-100 PSI

QTY 12  
H3266



672902



674909



670901



670926A



672927B

For the most part, JET Hand Tools carry a lifetime warranty. However, the following JET hand tools have wear parts that are not covered under warranty. The moving parts found on these products can wear out through normal use and can easily be replaced by purchasing and installing the repair kits indicated below.

### Flex Bar

- The swivel drive ends on these units are designed to fail before the chrome drive holder breaks under extreme use
- The drive end is easily replaced by removing the drive end screw and broken drive end and installing the replacement drive end and screw

PROD. NO.	MOD. NO.	Drive	Repair Kit
<b>672902</b>	SA1201	1/2"	<b>900218</b>
<b>672903</b>	SA1202	1/2"	<b>900218</b>
<b>672918</b>	SA1213	1/2"	<b>900219</b>
<b>673909</b>	SA7508	3/4"	<b>900230</b>
<b>674909</b>	SA1008	1"	<b>900246</b>

## RATCHETS

- Like all makes of ratchets, JET ratcheting mechanisms will wear with extensive use or break when extreme pressure or abuse is applied
- JET ratchet repair kits are available for all ratchet models and are available for purchase and easily installed by your JET hand tool distributor

### RH - Standard Duty

PROD. NO.	MOD. NO.	Drive	Repair Kit
<b>670901</b>	RH-25	1/4"	<b>900202</b>
<b>671901</b>	RH-38	3/8"	<b>900203</b>
<b>672901</b>	RH-50	1/2"	<b>900204</b>
<b>673901</b>	RH-75	3/4"	<b>900205</b>
<b>674901</b>	RH-100	1"	<b>900210</b>

### RHQ Series - Heavy Duty

<b>670926A</b>	RHQ-14	1/4"	<b>900235</b>
<b>670928</b>	RHQ-14L	1/4"	<b>900235</b>
<b>670929</b>	RHQ-14F	1/4" (Flex)	<b>900235</b>
<b>671926A</b>	RHQ-38	3/8"	<b>900236</b>
<b>671942</b>	RHQ-38FS	3/8" (Flex)	<b>900253</b>
<b>671942A</b>	RHQ-38FS	3/8"	<b>900236</b>
<b>671943</b>	RHQ-38F2	3/8" (Flex)	<b>900253</b>
<b>671943A</b>	RHQ-38F2	3/8"	<b>900236</b>
<b>671945</b>	RHQ-38L	3/8"	<b>900236</b>
<b>672926B</b>	RHQ-12	1/2"	<b>900239</b>
<b>672927B</b>	RHQ-12L	1/2"	<b>900239</b>
<b>672929</b>	RHQ-12F	1/2" (Flex)	<b>900259</b>
<b>673922</b>	RHQ-34	3/4"	<b>900215</b>

## RHD Series - Super Heavy Duty

PROD. NO.	MOD. NO.	Drive	Repair Kit
673923	RHD-3400	3/4"	900240
674906	RHD-1036	1"	900241

## RA Series - Ratchet adapters

670921	RA1452	1/4"	900266
671921	RA3852	3/8"	900267
672921	RA1252	1/2"	900268

## SH Series

670922	SH270-14	1/4"	900261
671922	SH270-38	3/8"	900262
672922	SH270-12	1/2"	900263

## HT72 - 72 Tooth Twin Pawl Series

670927	HT-1472	1/4"	900225
671928	HT-3872	3/8"	900226
672928	HT-1272	1/2"	900227
673924	HT-3472	3/4"	900228

## MHR Series - 60 Tooth Mini Head

671941	MHR-3860	3/8"	900252
--------	----------	------	--------

## SR3872 - 72 Tooth Stubby

671940	SR3872	3/8"	900251
671940B	SR3872	3/8"	900251

## HSR 3800 - Rotating Head Ratchet

PROD. NO.	MOD. NO.	Drive	Repair Kit	Handle Repair Kit
671944	HSR-3800	3/8"	900257	900258



674906

673923



670921



670927



671941



# TORQUE WRENCHES

## Torque Wrenches



718906

PROD. NO.	MOD. NO.	Drive	Repair Kit
<b>718902</b>	JTW-1425	1/4"	PDN-JTW1425-RK
<b>718903</b>	JMTW-1425	1/4"	PDN-JMTW1425RK
<b>718906</b>	JMTW-3800	3/8"	PUT-JMTW3800
<b>718906</b>	JMTW-3800A	3/8"	PUT-JMTW3800A
<b>718908</b>	JTW-3880	3/8"	PDN-JTW3880-RK
<b>718909</b>	JMTW-3875	3/8"	PDN-JMTW3875-RK
<b>718909</b>	JMTW-3875HD	3/8"	PDN-JMTW3875A-RK
<b>718861 – 865</b>	Tire torque wrenches	1/2"	PDN-JTTW-RK
<b>718911</b>	JTW-12150	1/2"	PDN-JTW12150-RK
<b>718912</b>	JTW-12250	1/2"	PDN-JTW12250-RK
<b>718913</b>	JMTW-12150	1/2"	PDN-JMTW12250-RK
<b>718913</b>	JMTW-12150HD	1/2"	PDN-JMTW12250A-RK
<b>718914</b>	JMTW-12250 (black handle)	1/2"	PDN-JMTW12250-RK
<b>718914</b>	JMTW-12250 (red handle)	1/2"	PDN-JTW12250-RK
<b>718914</b>	JMTW-12250HD (go through plug)	1/2"	PDN-JMTW12250A-RK
<b>718933</b>	JPTW-38100	3/8"	PDN-JPTW38100-RK
<b>718935</b>	JPTW-12150	1/2"	PDN-JPTW12150-RK
<b>718936</b>	JPTW-12250	1/2"	PDN-JPTW12250-RK
<b>719069</b>	JMTW-5250	1/2"	PUT-JMTW5250
<b>719069</b>	JMTW-5250A	1/2"	PUT-JMTW5250A
<b>718916</b>	JMTW-7500	3/4"	PUT-JMTW7500
<b>718917</b>	JTW-34300	3/4"	PDN-JTW34600-RK
<b>718918</b>	JTW-34600	3/4"	PDN-JTW34600-RK
<b>718922</b>	JTW-10700	1"	PDN-JTW10700-RK

# PIPE WRENCHES

## Pipe Wrenches – HD and AL Series



710230

Jaw Size	Hook Jaw	Knurls	Heel Jaw	Springs
8"	PMZ-1020802	PMZ-1020804	PMZ-1020815	PMZ-1020813
10"	PMZ-1021002	PMZ-1021004	PMZ-1021015	PMZ-1021013
12"	PMZ-1021202	PMZ-1021204	PMZ-1021215	PMZ-1021213
14"	PMZ-1021402	PMZ-1021404	PMZ-1021415	PMZ-1021413
18"	PMZ-1021802	PMZ-1021804	PMZ-1021815	PMZ-1021813
24"	PMZ-1022402	PMZ-1022404	PMZ-1022415	PMZ-1022413
36"	PMZ-1023602	PMZ-1023604	PMZ-1023615	PMZ-1023613
48"	PMZ-1044802	PMZ-1044804	PMZ-1044815	PMZ-1044813

## Pipe Wrenches – PW and PWA Series

8"	PDN-PW8HJ	PDN-PW8NT	PDN-PW8HJP	PDN-PW8SF
10"	PDN-PW10HJ	PDN-PW10NT	PDN-PW10HJP	PDN-PW10SF
12"	PDN-PW12HJ	PDN-PW12NT	PDN-PW12HJP	PDN-PW12SF
14"	PDN-PW14HJ	PDN-PW14NT	PDN-PW14HJP	PDN-PW14SF
18"	PDN-PW18HJ	PDN-PW18NT	PDN-PW18HJP	PDN-PW18SF
24"	PDN-PW24HJ	PDN-PW24NT	PDN-PW24HJP	PDN-PW24SF
36"	PDN-PW36HJ	PDN-PW36NT	PDN-PW36HJP	PDN-PW36SF
48"	PDN-PW48HJ	PDN-PW48NT	PDN-PW48HJP	PDN-PW48SF

# CUSHION GRIP MULTI-BIT DRIVERS REPLACEMENT BITS



## For 720531 (JKMD-5S) / 720534 (JKMD-10)

PROD. NO.	Size
<b>720580</b>	3/16" SLOT x #1 PHILLIPS
<b>720581</b>	3/16" SLOT x #2 SQUARE
<b>720582</b>	1/4" SLOT x #2 PHILLIPS
<b>720583</b>	#1 SQUARE x #2 SQUARE
<b>720584</b>	#3 PHILLIPS x #3 PHILLIPS

## For 720533 (JKMD-6) / 720590 (JRSD-19)

PROD. NO.	Size
<b>720592</b>	1/8" SLOT x #0 PHILLIPS
<b>720593</b>	3/16" SLOT x #1 PHILLIPS
<b>720594</b>	1/4" SLOT x #2 PHILLIPS
<b>720595</b>	#1 SQUARE x #2 SQUARE
<b>720596</b>	T10 x T15 TORX®
<b>720597</b>	T20 x T25 TORX®
<b>720598</b>	1/8" HEX x 3/16" HEX
<b>720599</b>	5/16" SLOT x #3 PHILLIPS



# MULTI-BIT DRIVERS REPLACEMENT BITS

## Replacements Bits

Replacement Bit For H3400 (P0 - P3)	<b>H3400C</b>
Replacement Bit For H3400 (P1 - P2)	<b>H3400D</b>
Replacement Bit For H3400 (S1 - S2)	<b>H3400E</b>
Replacement Bit For H3400 (T10 - T15)	<b>H3400F</b>
Replacement Bit For H3400 (T20 - T25)	<b>H3400G</b>
Replacement Bit For H3400 (T27 - T30)	<b>H3400H</b>
Replacement Bit For H3400 (F4 - F6)	<b>H3400J</b>
Replacement Bit For H3400 (S0 - S3)	<b>H3400K</b>



# WARRANTY POLICY

JET EQUIPMENT & TOOLS LTD.

**JET EQUIPMENT & TOOLS LTD. (JET)**, makes every effort to ensure its products are manufactured to the highest standards and each is warranted against defects in materials and workmanship for the useful life of the product when used for the purpose for which it was designed.

This warranty applies only to JET products purchased new from a JET authorized distributor. JET product warranties are extended to the original retail purchaser only.

This warranty does not apply to any product showing signs of abuse, misuse, alteration, or having been improperly maintained or repaired.

This warranty does not cover damage attributable to normal wear and tear.

Any JET product that fails during normal use and is within the specified warranty period for that product will be repaired or replaced at JET's discretion. Repairs and/or replacements are warranted as described for the specific product and only for the remainder of the original warranty period.

Repair or replacement is the exclusive remedy for defective product under this warranty. Warranty is expressly in lieu of all other warranties, including the implied warranty of merchantability or any implied warranty of fitness for a particular application.

Any JET product for which there is a warranty claim should be returned PREPAID to an authorized JET distributor or service center. Authorized Warranty Depots are found at [www.jetgroupbrands.com](http://www.jetgroupbrands.com)

ALL warranty claims must be accompanied by proof of purchase and an explanation of the defect or failure. It is the customer's responsibility to provide this information.

JET shall not be held liable for any consequential or incidental damages for breach of any expressed or implied warranty on their products.

No claims for damages of any type will be considered and all products are sold with this understanding.

Any costs incurred to obtain warranty consideration or services are the Customer's responsibility including shipping and handling, travel, lost time, or lost production.

**Except as listed below, all JET Hand Tool products are covered by our Limited Lifetime Warranty.**

**NOTE: Specifically excluded from this guarantee are reducing adaptors, thin wall power sockets, mag wheel power sockets, power bits and insert bits and accessories, hacksaw blades, scratch brushes, damaged insulating materials, kneeling pads, consumable components**

## Indestructible Handle Hammers – Limited Lifetime Warranty

Warranty extends to fracturing or permanent deformation of the handle only, and only when used for its intended purpose. Heads are warranted not to suffer a complete separation; however in time it is possible the locking plate will begin to bend, indicating the tool has reached its useful life and may indicate the need for a heavier hammer. Chips, cracks, and cuts to the rubber overmould are excluded from this warranty.

## Two Year Warranty

Machinery  
Torque Wrenches

**NOTE: Dropping or striking against hard objects, using for removal of fasteners, or failure to return wrench to lowest setting can all contribute to loss of accuracy and is not the fault of the tool.**

CALIBRATION IS NOT COVERED BY WARRANTY EXCEPT WHEN REQUIRED DUE TO WARRANTY REPAIR SERVICE

## One Year Warranty

Hose Reels (hose is discretionary based on examination)  
Lubricating Equipment (seals and hoses excluded)  
Torque Multipliers  
Precision Measuring Tools  
Electronic Measuring Tools Thermometers  
Tire Gauges Compression/Pressure Gauges  
Automotive Gauges  
Timing Lights  
Pry Bars and Wrecking Bars  
Gear Pullers, Bearing Separators

**NOTE: Batteries supplied with certain products may have been exposed to a long shelf life resulting in low energy or dead batteries. Please source replacement batteries locally.**

Dead batteries do not constitute a warranty claim.

## Repairable Wear Parts

Flex Bar Swivels, Ratchet Repair Kits, Torque Wrench Repair Kits, Pipe Wrench Jaws, Springs and Knurls, Bolt Cutter heads, Bench Vise (excluding casting).

## Tool Boxes

Tool boxes are warranted against defects in materials and workmanship when used for the purpose for which they were designed for the periods specified below. Moving heavily loaded tool boxes is the most common cause of damage. If the tool box must be moved regularly choose one of a sufficient duty rating.

Super Pro, SHD, Treasure Series – Limited Lifetime  
Pro Series and B&G Series – 5 years  
SUMO Series, jobsite, truck box, and hand held tool boxes – 2 years  
Rolling tool carts – 1 year

**NOTE: Evidence of drawer overload, shock, impact, use as a mobile tool box (unless specifically designed for this purpose) or lack of maintenance voids warranty.**

## Numerical Index

190918.....	212	350113.....	242	351005.....	249	390298.....	207	601202.....	56
190968.....	213	350114.....	244	355002.....	214	390299.....	207	601216.....	58
200225.....	221	350115.....	244	355003.....	214	390452.....	208	601219.....	51
200275.....	221	350116.....	245	355091.....	214	390453.....	208	601220.....	51
200278.....	222	350117.....	245	355105.....	215	390457.....	208	601224.....	52
200357.....	223	350118.....	246	355115.....	215	390458.....	208	601226.....	52
222326.....	224	350121.....	242	355130.....	215	390482.....	208	601227.....	51
222332.....	224	350122.....	242	355153.....	216	391103.....	187	601229.....	51
222335.....	225	350124.....	242	355158.....	216	391104.....	187	601231.....	59
240153.....	220	350125.....	242	355191.....	217	391106.....	187	601232.....	59
240154.....	220	350151.....	232	355193.....	217	391107.....	187	601234.....	52
252926.....	226	350152.....	232	390102.....	205	391109.....	187	601236.....	52
310006.....	314	350155.....	232	390103.....	205	391110.....	187	601312.....	54
310008.....	314	350156.....	233	390104.....	205	522163.....	220	601313.....	53
310016.....	313	350157.....	243	390105.....	205	522164.....	220	601314.....	54
310018.....	313	350158.....	239	390106.....	205	522165.....	220	601316.....	53
310022.....	315	350159.....	243	390108.....	205	522173.....	220	601317.....	53
310041.....	315	350161.....	233	390110.....	205	522174.....	220	601318.....	53
310122.....	308	350162.....	233	390112.....	205	522175.....	220	601319.....	54
310131.....	308	350171.....	234	390122.....	205	522176.....	220	601320.....	54
310132.....	308	350173.....	234	390123.....	205	522263.....	220	601321.....	59
310133.....	308	350181.....	234	390124.....	205	522264.....	220	601405.....	55
310136.....	308	350182.....	234	390125.....	205	522265.....	220	601406.....	55
310211.....	311	350189.....	236	390126.....	205	522273.....	220	601407.....	55
310212.....	311	350201.....	234	390127.....	205	522274.....	220	601801.....	58
310213.....	311	350202.....	234	390129.....	205	522275.....	220	601802.....	56
310223.....	311	350203.....	236	390142.....	204	550121.....	220	601803.....	56
310501.....	309	350204.....	236	390143.....	204	550123.....	220	601804.....	57
310502.....	309	350214.....	249	390144.....	204	550124.....	220	601805.....	57
310511.....	311	350215.....	234	390145.....	204	550125.....	220	601806.....	58
310602.....	312	350216.....	234	390146.....	204	550141.....	220	601808.....	57
310603.....	312	350217.....	236	390151.....	204	550142.....	220	601811.....	59
310604.....	312	350218.....	236	390153.....	204	550143.....	220	610201.....	74
310605.....	312	350251.....	238	390155.....	204	566231.....	202	610203.....	74
310902.....	310	350252.....	238	390157.....	204	566232.....	202	610207.....	74
310903.....	310	350253.....	238	390202.....	206	566233.....	202	610208.....	74
310905.....	310	350254.....	238	390204.....	206	600115.....	42	610217.....	74
320151.....	209	350255.....	238	390206.....	206	600116.....	42	610218.....	74
320152.....	209	350256.....	238	390208.....	206	600125.....	43	610302.....	75
320153.....	209	350257.....	237	390210.....	206	600126.....	43	610303.....	75
320154.....	209	350258.....	237	390212.....	206	600223.....	44	610308.....	76
320312.....	210	350259.....	237	390224.....	206	600226.....	44	610310.....	76
320313.....	210	350260.....	237	390226.....	206	600229.....	44	610314.....	76
320314.....	210	350261.....	238	390228.....	206	600234.....	45	610315.....	76
320315.....	210	350262.....	238	390230.....	206	600241.....	45	610321.....	75
320316.....	210	350263.....	237	390232.....	206	600242.....	45	610323.....	75
320317.....	210	350264.....	237	390233.....	206	600323.....	46	610326.....	84
320318.....	210	350265.....	238	390248.....	207	600326.....	46	610327.....	77
320319.....	210	350306.....	239	390250.....	207	600331.....	47	610328.....	75
321124.....	211	350307.....	239	390252.....	207	600341.....	47	610329.....	75
321336.....	211	350311.....	240	390254.....	207	600402.....	48	610331.....	84
350103.....	244	350312.....	240	390289.....	207	600406.....	48	610333.....	84
350105.....	243	350391.....	240	390290.....	207	600503.....	49	610334.....	77
350106.....	243	350511.....	247	390291.....	207	600505.....	49	610335.....	77
350107.....	246	350512.....	248	390292.....	207	601102.....	50	610338.....	77
350108.....	241	350514.....	248	390293.....	207	601107.....	50	610339.....	77
350109.....	241	350515.....	248	390294.....	207	601111.....	59	610340.....	84
350110.....	241	350520.....	248	390295.....	207	601113.....	50	610341.....	78
350111.....	241	351003.....	249	390296.....	207	601118.....	50	610382.....	78
350112.....	241	351004.....	249	390297.....	207	601201.....	56	610388.....	78

## Numerical Index

610391.....	85	670503.....	62	671108.....	60	671610.....	62	671945.....	34, 346
610401.....	80	670504.....	62	671110.....	60	671611.....	62	671947.....	71
610402.....	80	670505.....	62	671112.....	60	671612.....	62	671948.....	71
610403.....	80	670506.....	62	671114.....	60	671613.....	62	671949.....	71
610404.....	80	670507.....	62	671116.....	60	671614.....	62	671951.....	72
610406.....	80	670508.....	62	671118.....	60	671615.....	62	671952.....	72
610407.....	81	670509.....	62	671120.....	60	671616.....	62	671953.....	72
610408.....	81	670510.....	62	671122.....	60	671617.....	62	671954.....	72
610409.....	81	670511.....	62	671124.....	60	671618.....	62	672112.....	61
610410.....	81	670512.....	62	671126.....	60	671619.....	62	672114.....	61
610411.....	85	670513.....	62	671128.....	60	671708.....	62	672116.....	61
610421.....	85	670602.....	62	671130.....	60	671709.....	62	672118.....	61
610501.....	81	670604.....	62	671132.....	60	671710.....	62	672120.....	61
610503.....	82	670606.....	62	671208.....	60	671711.....	62	672122.....	61
610504.....	82	670607.....	62	671210.....	60	671712.....	62	672124.....	61
610506.....	82	670608.....	62	671212.....	60	671713.....	62	672126.....	61
610508.....	82	670609.....	62	671214.....	60	671714.....	62	672128.....	61
610509.....	81	670610.....	62	671216.....	60	671715.....	62	672130.....	61
610515.....	83	670611.....	62	671218.....	60	671716.....	62	672132.....	61
610901.....	87	670612.....	62	671220.....	60	671717.....	62	672134.....	61
610902.....	87	670702.....	62	671222.....	60	671718.....	62	672136.....	61
610903.....	86	670704.....	62	671224.....	60	671719.....	62	672138.....	61
610906.....	86	670705.....	62	671312.....	60	671721.....	62	672140.....	61
670106.....	60	670706.....	62	671314.....	60	671808.....	62	672212.....	61
670107.....	60	670707.....	62	671316.....	60	671809.....	62	672214.....	61
670108.....	60	670708.....	62	671318.....	60	671810.....	62	672216.....	61
670109.....	60	670709.....	62	671320.....	60	671811.....	62	672218.....	61
670110.....	60	670710.....	62	671322.....	60	671812.....	62	672220.....	61
670111.....	60	670711.....	62	671324.....	60	671813.....	62	672222.....	61
670112.....	60	670712.....	62	671326.....	60	671814.....	62	672224.....	61
670114.....	60	670713.....	62	671328.....	60	671815.....	62	672226.....	61
670116.....	60	670802.....	62	671408.....	60	671816.....	62	672228.....	61
670206.....	60	670804.....	62	671410.....	60	671817.....	62	672230.....	61
670207.....	60	670806.....	62	671412.....	60	671818.....	62	672232.....	61
670208.....	60	670807.....	62	671414.....	60	671819.....	62	672234.....	61
670209.....	60	670808.....	62	671416.....	60	671901.....	346	672236.....	61
670210.....	60	670809.....	62	671418.....	60	671902.....	68	672238.....	61
670211.....	60	670810.....	62	671420.....	60	671904.....	70	672240.....	61
670212.....	60	670811.....	62	671422.....	60	671905.....	70	672314.....	61
670214.....	60	670812.....	62	671424.....	60	671907.....	70	672316.....	61
670216.....	60	670901.....	346	671506.....	62	671908.....	70	672318.....	61
670306.....	60	670902.....	68	671507.....	62	671909.....	69	672320.....	61
670307.....	60	670904.....	70	671508.....	62	671910.....	67	672322.....	61
670308.....	60	670905.....	70	671509.....	62	671911.....	69	672324.....	61
670309.....	60	670906.....	70	671510.....	62	671913.....	67	672326.....	61
670310.....	60	670907.....	69	671511.....	62	671914.....	67	672328.....	61
670311.....	60	670908.....	67	671512.....	62	671917.....	67	672330.....	61
670312.....	60	670911.....	67	671513.....	62	671921.....	38, 347	672332.....	61
670314.....	60	670912.....	69	671514.....	62	671922.....	36, 347	672334.....	61
670316.....	60	670913.....	67	671515.....	62	671923.....	36, 343	672336.....	61
670406.....	60	670915.....	70	671516.....	62	671926.....	34	672340.....	61
670407.....	60	670921.....	38	671517.....	62	671928.....	35, 347	672414.....	61
670408.....	60	670921.....	347	671518.....	62	671930.....	69	672416.....	61
670409.....	60	670922.....	36, 347	671519.....	62	671932.....	60	672418.....	61
670410.....	60	670926.....	34	671520.....	62	671934.....	60	672420.....	61
670411.....	60	670927.....	35	671521.....	62	671940.....	347	672422.....	61
670412.....	60	670927.....	347	671522.....	62	671941.....	37, 347	672424.....	61
670414.....	60	670928.....	34, 346	671524.....	62	671942.....	34, 346	672426.....	61
670416.....	60	670929.....	34, 346	671608.....	62	671943.....	34, 346	672428.....	61
670502.....	62	670930.....	69	671609.....	62	671944.....	37, 347	672430.....	61



## Numerical Index

672432.....	61	672817.....	63	673418.....	61	674250.....	61	677710.....	66
672434.....	61	672818.....	63	673419.....	61	674901.....	39, 346	677711.....	66
672436.....	61	672819.....	63	673420.....	61	674903.....	70	677726.....	66
672440.....	61	672820.....	63	673421.....	61	674904.....	69	677727.....	66
672508.....	63	672821.....	63	673422.....	61	674905.....	70	677728.....	66
672509.....	63	672822.....	63	673423.....	61	674906.....	40, 347	677729.....	66
672510.....	63	672824.....	63	673424.....	61	674907.....	40	677730.....	66
672511.....	63	672901.....	346	673426.....	61	674909.....	68, 346	677731.....	66
672512.....	63	672902.....	68, 346	673428.....	61	677021.....	64	677759.....	66
672513.....	63	672903.....	68, 346	673429.....	61	677022.....	64	677761.....	66
672514.....	63	672904.....	70	673430.....	61	677023.....	64	677763.....	66
672515.....	63	672905.....	70	673432.....	61	677071.....	65	677764.....	66
672516.....	63	672906.....	70	673619.....	63	677072.....	65	677766.....	66
672517.....	63	672907.....	69	673621.....	63	677073.....	65	677767.....	66
672518.....	63	672908.....	67	673622.....	63	677127.....	64	677783.....	66
672519.....	63	672909.....	69	673623.....	63	677128.....	64	677784.....	66
672520.....	63	672911.....	67	673624.....	63	677130.....	64	677785.....	66
672521.....	63	672912.....	67	673626.....	63	677132.....	64	677786.....	66
672522.....	63	672913.....	67	673627.....	63	677177.....	65	677787.....	66
672523.....	63	672914.....	70	673629.....	63	677178.....	65	677803.....	66
672524.....	63	672918.....	68, 346	673630.....	63	677179.....	65	677804.....	66
672527.....	63	672921.....	38, 347	673632.....	63	677180.....	65	677805.....	66
672530.....	63	672922.....	36, 347	673635.....	63	677204.....	64	677806.....	66
672532.....	63	672923.....	36, 343	673636.....	63	677205.....	64	677807.....	66
672610.....	63	672926.....	34	673638.....	63	677206.....	64	677809.....	66
672611.....	63	672927.....	34	673641.....	63	677207.....	64	677810.....	66
672612.....	63	672928.....	35, 347	673646.....	63	677208.....	64	677821.....	66
672613.....	63	672929.....	34, 346	673650.....	63	677210.....	64	677822.....	66
672614.....	63	672930.....	69	673901.....	39, 346	677212.....	64	677823.....	66
672615.....	63	672932.....	68	673903.....	70	677224.....	64	677824.....	66
672616.....	63	672933.....	68	673904.....	70	677225.....	64	677825.....	66
672617.....	63	672947.....	71	673905.....	70	677226.....	64	677826.....	66
672618.....	63	672948.....	71	673906.....	69	677227.....	64	677827.....	66
672619.....	63	672949.....	71	673907.....	67	677228.....	64	677828.....	66
672620.....	63	672951.....	72	673909.....	68, 346	677230.....	64	677830.....	66
672621.....	63	672952.....	72	673910.....	69	677232.....	64	677832.....	66
672622.....	63	672953.....	72	673911.....	68	677253.....	65	677845.....	66
672624.....	63	673212.....	61	673912.....	67	677254.....	65	677847.....	66
672710.....	63	673214.....	61	673913.....	40	677255.....	65	677851.....	66
672712.....	63	673215.....	61	673914.....	40	677256.....	65	677852.....	66
672713.....	63	673216.....	61	673922.....	39, 346	677257.....	65	677853.....	66
672714.....	63	673217.....	61	673923.....	40, 347	677258.....	65	677855.....	66
672715.....	63	673218.....	61	673924.....	39, 347	677260.....	65	677857.....	66
672716.....	63	673219.....	61	674223.....	61	677274.....	65	677859.....	66
672717.....	63	673220.....	61	674224.....	61	677275.....	65	677861.....	66
672718.....	63	673221.....	61	674226.....	61	677276.....	65	677863.....	66
672719.....	63	673222.....	61	674227.....	61	677277.....	65	677865.....	66
672720.....	63	673223.....	61	674228.....	61	677278.....	65	680915.....	87
672721.....	63	673224.....	61	674229.....	61	677279.....	65	680918.....	87
672722.....	63	673225.....	61	674230.....	61	677280.....	65	681110.....	88
672723.....	63	673226.....	61	674232.....	61	677316.....	64	681112.....	88
672724.....	63	673227.....	61	674234.....	61	677318.....	64	681114.....	88
672727.....	63	673228.....	61	674235.....	61	677320.....	64	681116.....	88
672810.....	63	673229.....	61	674236.....	61	677362.....	65	681118.....	88
672811.....	63	673230.....	61	674238.....	61	677364.....	65	681120.....	88
672812.....	63	673232.....	61	674240.....	61	677366.....	65	681122.....	88
672813.....	63	673414.....	61	674242.....	61	677706.....	66	681124.....	88
672814.....	63	673415.....	61	674244.....	61	677707.....	66	681126.....	88
672815.....	63	673416.....	61	674247.....	61	677708.....	66	681128.....	88
672816.....	63	673417.....	61	674248.....	61	677709.....	66	681130.....	88

## Numerical Index

681132.....	<b>88</b>	682140.....	<b>88</b>	682523.....	<b>89</b>	682953.....	<b>86</b>	683248.....	<b>88</b>
681210.....	<b>88</b>	682142.....	<b>88</b>	682524.....	<b>89</b>	682954.....	<b>86</b>	683250.....	<b>88</b>
681212.....	<b>88</b>	682144.....	<b>88</b>	682525.....	<b>89</b>	682955.....	<b>86</b>	683252.....	<b>88</b>
681214.....	<b>88</b>	682146.....	<b>88</b>	682526.....	<b>89</b>	682961.....	<b>79</b>	683254.....	<b>88</b>
681216.....	<b>88</b>	682148.....	<b>88</b>	682527.....	<b>89</b>	682964.....	<b>79</b>	683256.....	<b>88</b>
681218.....	<b>88</b>	682150.....	<b>88</b>	682528.....	<b>89</b>	682965.....	<b>79</b>	683258.....	<b>88</b>
681220.....	<b>88</b>	682152.....	<b>88</b>	682529.....	<b>89</b>	682966.....	<b>79</b>	683260.....	<b>88</b>
681222.....	<b>88</b>	682154.....	<b>88</b>	682530.....	<b>89</b>	682967.....	<b>79</b>	683262.....	<b>88</b>
681224.....	<b>88</b>	682156.....	<b>88</b>	682532.....	<b>89</b>	682968.....	<b>79</b>	683264.....	<b>88</b>
681226.....	<b>88</b>	682158.....	<b>88</b>	682533.....	<b>89</b>	682981.....	<b>78</b>	683519.....	<b>89</b>
681228.....	<b>88</b>	682160.....	<b>88</b>	682534.....	<b>89</b>	682982.....	<b>78</b>	683521.....	<b>89</b>
681230.....	<b>88</b>	682162.....	<b>88</b>	682535.....	<b>89</b>	682983.....	<b>78</b>	683522.....	<b>89</b>
681232.....	<b>88</b>	682164.....	<b>88</b>	682536.....	<b>89</b>	682985.....	<b>78</b>	683523.....	<b>89</b>
681507.....	<b>89</b>	682212.....	<b>88</b>	682610.....	<b>89</b>	682986.....	<b>78</b>	683524.....	<b>89</b>
681508.....	<b>89</b>	682214.....	<b>88</b>	682611.....	<b>89</b>	682991.....	<b>78</b>	683526.....	<b>89</b>
681509.....	<b>89</b>	682216.....	<b>88</b>	682612.....	<b>89</b>	682992.....	<b>78</b>	683527.....	<b>89</b>
681510.....	<b>89</b>	682218.....	<b>88</b>	682613.....	<b>89</b>	682993.....	<b>78</b>	683529.....	<b>89</b>
681511.....	<b>89</b>	682220.....	<b>88</b>	682614.....	<b>89</b>	682995.....	<b>78</b>	683530.....	<b>89</b>
681512.....	<b>89</b>	682222.....	<b>88</b>	682615.....	<b>89</b>	682996.....	<b>78</b>	683532.....	<b>89</b>
681513.....	<b>89</b>	682224.....	<b>88</b>	682616.....	<b>89</b>	683124.....	<b>88</b>	683533.....	<b>89</b>
681514.....	<b>89</b>	682226.....	<b>88</b>	682617.....	<b>89</b>	683126.....	<b>88</b>	683535.....	<b>89</b>
681515.....	<b>89</b>	682228.....	<b>88</b>	682618.....	<b>89</b>	683128.....	<b>88</b>	683536.....	<b>89</b>
681516.....	<b>89</b>	682230.....	<b>88</b>	682619.....	<b>89</b>	683130.....	<b>88</b>	683538.....	<b>89</b>
681517.....	<b>89</b>	682232.....	<b>88</b>	682620.....	<b>89</b>	683132.....	<b>88</b>	683541.....	<b>89</b>
681518.....	<b>89</b>	682234.....	<b>88</b>	682621.....	<b>89</b>	683134.....	<b>88</b>	683546.....	<b>89</b>
681519.....	<b>89</b>	682236.....	<b>88</b>	682622.....	<b>89</b>	683136.....	<b>88</b>	683550.....	<b>89</b>
681607.....	<b>89</b>	682238.....	<b>88</b>	682623.....	<b>89</b>	683138.....	<b>88</b>	683619.....	<b>89</b>
681608.....	<b>89</b>	682240.....	<b>88</b>	682624.....	<b>89</b>	683140.....	<b>88</b>	683621.....	<b>89</b>
681609.....	<b>89</b>	682242.....	<b>88</b>	682625.....	<b>89</b>	683142.....	<b>88</b>	683622.....	<b>89</b>
681610.....	<b>89</b>	682244.....	<b>88</b>	682626.....	<b>89</b>	683144.....	<b>88</b>	683623.....	<b>89</b>
681611.....	<b>89</b>	682246.....	<b>88</b>	682627.....	<b>89</b>	683146.....	<b>88</b>	683624.....	<b>89</b>
681612.....	<b>89</b>	682248.....	<b>88</b>	682628.....	<b>89</b>	683148.....	<b>88</b>	683626.....	<b>89</b>
681613.....	<b>89</b>	682250.....	<b>88</b>	682629.....	<b>89</b>	683150.....	<b>88</b>	683627.....	<b>89</b>
681614.....	<b>89</b>	682252.....	<b>88</b>	682630.....	<b>89</b>	683152.....	<b>88</b>	683629.....	<b>89</b>
681615.....	<b>89</b>	682254.....	<b>88</b>	682632.....	<b>89</b>	683154.....	<b>88</b>	683630.....	<b>89</b>
681616.....	<b>89</b>	682256.....	<b>88</b>	682633.....	<b>89</b>	683156.....	<b>88</b>	683632.....	<b>89</b>
681617.....	<b>89</b>	682258.....	<b>88</b>	682634.....	<b>89</b>	683158.....	<b>88</b>	683633.....	<b>89</b>
681618.....	<b>89</b>	682260.....	<b>88</b>	682635.....	<b>89</b>	683160.....	<b>88</b>	683635.....	<b>89</b>
681619.....	<b>89</b>	682262.....	<b>88</b>	682636.....	<b>89</b>	683162.....	<b>88</b>	683636.....	<b>89</b>
681911.....	<b>87</b>	682264.....	<b>88</b>	682713.....	<b>89</b>	683164.....	<b>88</b>	683638.....	<b>89</b>
681915.....	<b>87</b>	682316.....	<b>88</b>	682714.....	<b>89</b>	683166.....	<b>88</b>	683641.....	<b>89</b>
681917.....	<b>87</b>	682318.....	<b>88</b>	682715.....	<b>89</b>	683168.....	<b>88</b>	683646.....	<b>89</b>
681918.....	<b>87</b>	682320.....	<b>88</b>	682716.....	<b>89</b>	683170.....	<b>88</b>	683650.....	<b>89</b>
681952.....	<b>86</b>	682322.....	<b>88</b>	682717.....	<b>89</b>	683172.....	<b>88</b>	683951.....	<b>86</b>
681953.....	<b>86</b>	682324.....	<b>88</b>	682718.....	<b>89</b>	683174.....	<b>88</b>	683952.....	<b>86</b>
681954.....	<b>86</b>	682326.....	<b>88</b>	682719.....	<b>89</b>	683176.....	<b>88</b>	683953.....	<b>86</b>
682112.....	<b>88</b>	682328.....	<b>88</b>	682721.....	<b>89</b>	683178.....	<b>88</b>	683954.....	<b>86</b>
682114.....	<b>88</b>	682510.....	<b>89</b>	682722.....	<b>89</b>	683180.....	<b>88</b>	683955.....	<b>87</b>
682116.....	<b>88</b>	682511.....	<b>89</b>	682867.....	<b>78</b>	683224.....	<b>88</b>	684124.....	<b>88</b>
682118.....	<b>88</b>	682512.....	<b>89</b>	682869.....	<b>78</b>	683226.....	<b>88</b>	684126.....	<b>88</b>
682120.....	<b>88</b>	682513.....	<b>89</b>	682871.....	<b>78</b>	683228.....	<b>88</b>	684128.....	<b>88</b>
682122.....	<b>88</b>	682514.....	<b>89</b>	682876.....	<b>78</b>	683230.....	<b>88</b>	684130.....	<b>88</b>
682124.....	<b>88</b>	682515.....	<b>89</b>	682878.....	<b>78</b>	683232.....	<b>88</b>	684132.....	<b>88</b>
682126.....	<b>88</b>	682516.....	<b>89</b>	682911.....	<b>87</b>	683234.....	<b>88</b>	684134.....	<b>88</b>
682128.....	<b>88</b>	682517.....	<b>89</b>	682915.....	<b>87</b>	683236.....	<b>88</b>	684136.....	<b>88</b>
682130.....	<b>88</b>	682518.....	<b>89</b>	682917.....	<b>87</b>	683238.....	<b>88</b>	684138.....	<b>88</b>
682132.....	<b>88</b>	682519.....	<b>89</b>	682918.....	<b>87</b>	683240.....	<b>88</b>	684140.....	<b>88</b>
682134.....	<b>88</b>	682520.....	<b>89</b>	682938.....	<b>86</b>	683242.....	<b>88</b>	684142.....	<b>88</b>
682136.....	<b>88</b>	682521.....	<b>89</b>	682939.....	<b>86</b>	683244.....	<b>88</b>	684144.....	<b>88</b>
682138.....	<b>88</b>	682522.....	<b>89</b>	682952.....	<b>86</b>	683246.....	<b>88</b>	684146.....	<b>88</b>

## Numerical Index

684148.....	88	684276.....	88	688058.....	90	700322.....	99	700566.....	93
684150.....	88	684278.....	88	688060.....	90	700331.....	100	700567.....	93
684152.....	88	684280.....	88	688062.....	90	700336.....	100	700568.....	93
684154.....	88	684282.....	88	688064.....	90	700361.....	98	700569.....	93
684156.....	88	684284.....	88	688066.....	90	700371.....	99	700571.....	93
684158.....	88	684288.....	88	688110.....	90	700372.....	99	700572.....	93
684160.....	88	684614.....	83	688111.....	90	700381.....	100	700575.....	93
684162.....	88	684616.....	83	688112.....	90	700386.....	100	700577.....	93
684164.....	88	684619.....	83	688114.....	90	700391.....	102, 343	700621.....	95
684165.....	88	684622.....	83	688116.....	90	700453.....	96	700622.....	95
684166.....	88	684921.....	83	688118.....	90	700455.....	96	700623.....	95
684167.....	88	684922.....	83	688120.....	90	700456.....	96	700624.....	95
684168.....	88	684943.....	83	688122.....	90	700458.....	96	700625.....	95
684169.....	88	684944.....	83	688124.....	90	700459.....	96	700626.....	95
684170.....	88	684946.....	83	690104.....	35	700461.....	96	700627.....	95
684171.....	88	684951.....	86	690105.....	48	700464.....	96	700628.....	95
684172.....	88	684952.....	86	690106.....	34	700501.....	93	700629.....	95
684173.....	88	684955.....	87	690107.....	38	700502.....	93	700630.....	95
684174.....	88	684966.....	83	690111.....	67	700503.....	93	700631.....	95
684175.....	88	684971.....	83	690115.....	67	700504.....	93	700632.....	95
684176.....	88	684975.....	83	690120.....	70	700505.....	93	700633.....	95
684177.....	88	687211.....	90	690121.....	70	700506.....	93	700634.....	95
684178.....	88	687212.....	90	690122.....	72	700507.....	93	700635.....	95
684179.....	88	687213.....	90	690123.....	72	700508.....	93	700637.....	95
684180.....	88	687214.....	90	690124.....	71	700509.....	93	700672.....	95
684182.....	88	687215.....	90	690125.....	71	700510.....	93	700673.....	95
684184.....	88	687216.....	90	690130.....	69	700511.....	93	700674.....	95
684186.....	88	687217.....	90	699701.....	333	700512.....	93	700675.....	95
684188.....	88	687219.....	90	699702.....	331, 332	700513.....	93	700676.....	95
684190.....	88	687261.....	90	699703.....	329, 330	700514.....	93	700677.....	95
684192.....	88	687262.....	90	699704.....	326, 327, 328	700515.....	93	700678.....	95
684194.....	88	687263.....	90	670926A.....	346	700517.....	93	700679.....	95
684196.....	88	687265.....	90	671926A.....	346	700518.....	93	700680.....	95
684197.....	88	687267.....	90	671940B.....	347	700519.....	93	700681.....	95
684198.....	88	687269.....	90	671942A.....	346	700520.....	93	700682.....	95
684199.....	88	687272.....	90	671943A.....	346	700521.....	93	700683.....	95
684228.....	88	687274.....	90	672926B.....	346	700523.....	93	700684.....	95
684230.....	88	687320.....	90	672927B.....	346	700524.....	93	700685.....	95
684232.....	88	687324.....	90	700110.....	92	700525.....	93	700686.....	95
684234.....	88	687328.....	90	700115.....	92	700526.....	93	700687.....	95
684236.....	88	687332.....	90	700121.....	92	700527.....	93	700688.....	95
684238.....	88	687340.....	90	700125.....	93	700529.....	93	700689.....	95
684240.....	88	687367.....	90	700128.....	93	700531.....	93	700703.....	97
684242.....	88	687369.....	90	700132.....	94	700533.....	93	700704.....	97
684244.....	88	687372.....	90	700134.....	94	700535.....	93	700705.....	97
684246.....	88	687374.....	90	700136.....	94	700537.....	93	700706.....	97
684248.....	88	687377.....	90	700141.....	97	700552.....	93	700707.....	97
684250.....	88	687821.....	90	700164.....	98	700553.....	93	700708.....	97
684252.....	88	687822.....	90	700167.....	92	700554.....	93	700709.....	97
684254.....	88	687823.....	90	700173.....	92	700555.....	93	700755.....	97
684256.....	88	687825.....	90	700177.....	92	700556.....	93	700757.....	97
684258.....	88	687826.....	90	700182.....	94	700557.....	93	700758.....	97
684260.....	88	687827.....	90	700185.....	94	700558.....	93	700760.....	97
684262.....	88	687828.....	90	700186.....	94	700559.....	93	700762.....	97
684264.....	88	687829.....	90	700191.....	97	700560.....	93	700763.....	97
684266.....	88	687831.....	90	700201.....	92	700561.....	93	700764.....	97
684268.....	88	687833.....	90	700212.....	96	700562.....	93	700801.....	95
684270.....	88	688055.....	90	700308.....	98	700563.....	93	700802.....	95
684272.....	88	688056.....	90	700312.....	98	700564.....	93	700803.....	95
684274.....	88	688057.....	90	700321.....	99	700565.....	93	700804.....	95

## Numerical Index

700805.....	95	701177.....	101	710136.....	165	715215.....	106	719151.....	107
700806.....	95	701178.....	101	710142.....	164	715216.....	106	719153.....	107
700807.....	95	701179.....	101	710143.....	164	715217.....	106	719154.....	107
700808.....	95	701180.....	101	710144.....	164	715218.....	106	719155.....	107
700809.....	95	701181.....	101	710145.....	164	715219.....	106	719156.....	107
700810.....	95	701182.....	101	710147.....	164	715220.....	106	719157.....	107
700811.....	95	701183.....	101	710150.....	164	715221.....	106	719159.....	107
700853.....	95	701184.....	101	710156.....	164	715222.....	106	719162.....	107
700854.....	95	701191.....	102	710159.....	164	715223.....	106	719163.....	107
700855.....	95	701193.....	102	710225.....	165	715224.....	106	719165.....	107
700856.....	95	701196.....	37, 102	710227.....	165	715225.....	106	720354.....	123
700857.....	95	701201.....	101	710230.....	165	715226.....	106	720356.....	123
700858.....	95	701202.....	101	710236.....	165	715227.....	106	720360.....	123
700859.....	95	701203.....	101	710239.....	165	715228.....	106	720362.....	123
700860.....	95	701204.....	101	710245.....	164	715229.....	106	720363.....	123
700862.....	95	701205.....	101	710247.....	164	715230.....	106	720366.....	123
700863.....	95	701206.....	101	710250.....	164	715231.....	106	720371.....	123
700864.....	95	701207.....	101	710256.....	164	715232.....	106	720372.....	123
701101.....	101	701208.....	101	710259.....	164	715233.....	106	720373.....	123
701102.....	101	701209.....	101	710902.....	108	715234.....	106	720382.....	123
701103.....	101	701253.....	101	710903.....	108	715235.....	106	720392.....	123
701104.....	101	701254.....	101	710904.....	108	718902.....	116, 348	720404.....	125
701105.....	101	701255.....	101	710912.....	108	718903.....	117, 348	720406.....	125
701106.....	101	701256.....	101	710913.....	108	718906.....	116, 348	720421.....	125
701107.....	101	701257.....	101	710914.....	108	718908.....	116, 348	720422.....	125
701108.....	101	701258.....	101	711102.....	104	718909.....	117, 348	720423.....	125
701109.....	101	701259.....	101	711111.....	104	718911.....	116, 348	720431.....	125
701110.....	101	701260.....	101	711112.....	104	718912.....	116, 348	720432.....	125
701111.....	101	701261.....	101	711113.....	104	718913.....	117, 348	720433.....	125
701112.....	101	701262.....	101	711114.....	104	718914.....	117, 348	720444.....	125
701113.....	101	701263.....	101	711115.....	104	718916.....	348	720446.....	125
701121.....	101	701264.....	101	711116.....	104	718917.....	348	720523.....	126
701122.....	101	701301.....	101	711117.....	104	718918.....	116, 348	720524.....	126
701123.....	101	701302.....	101	711118.....	104	718922.....	116, 348	720527.....	126
701124.....	101	701303.....	101	711132.....	105	718933.....	117, 348	720531.....	344
701125.....	101	701304.....	101	711133.....	105	718935.....	348	720533.....	344
701126.....	101	701305.....	101	711134.....	105	718936.....	117, 348	720534.....	344
701127.....	101	701306.....	101	711135.....	105	718941.....	119	720537.....	131, 344
701128.....	101	701307.....	101	711136.....	105	718943.....	119	720551.....	344
701129.....	101	701308.....	101	711137.....	105	718946.....	119	720552.....	133, 344
701130.....	101	701309.....	101	711139.....	105	718952.....	118	720556.....	133, 344
701131.....	101	701310.....	101	711146.....	107	718956.....	118	720580.....	349
701132.....	101	701311.....	101	711152.....	105	718961.....	118	720581.....	349
701133.....	101	701353.....	101	711153.....	105	718962.....	118	720582.....	349
701153.....	101	701354.....	101	711154.....	105	718991.....	118	720583.....	349
701154.....	101	701355.....	101	711155.....	105	719001.....	103	720584.....	349
701155.....	101	701356.....	101	711156.....	105	719002.....	103	720590.....	131, 344
701156.....	101	701357.....	101	711157.....	105	719003.....	103	720591.....	131
701157.....	101	701358.....	101	711159.....	105	719004.....	103	720592.....	349
701158.....	101	701359.....	101	715201.....	106	719006.....	103	720593.....	349
701159.....	101	701360.....	101	715204.....	106	719007.....	103	720594.....	349
701160.....	101	701362.....	101	715205.....	106	719008.....	103	720595.....	349
701161.....	101	701363.....	101	715207.....	106	719009.....	103	720596.....	349
701162.....	101	701364.....	101	715208.....	106	719069.....	116, 348	720597.....	349
701163.....	101	710122.....	165	715209.....	106	719071.....	120	720598.....	349
701164.....	101	710123.....	165	715210.....	106	719072.....	120	720599.....	349
701173.....	101	710124.....	165	715211.....	106	719074.....	120	720605.....	129
701174.....	101	710125.....	165	715212.....	106	719075.....	120	720606.....	129
701175.....	101	710127.....	165	715213.....	106	719111.....	103	720607.....	129
701176.....	101	710130.....	165	715214.....	106	719121.....	103	720612.....	129

## Numerical Index

720613.....	129	721143.....	136	729104.....	135	730232.....	146	730738.....	152
720616.....	129	721144.....	136	729109.....	135	730236.....	148	731108.....	194
720621.....	129	721145.....	136	729112.....	134	730241.....	148	731112.....	194
720622.....	129	721146.....	136	729114.....	134	730246.....	148	731114.....	194
720623.....	129	721147.....	136	729115.....	135	730251.....	149	731118.....	194
720626.....	129	721151.....	136	729117.....	135	730311.....	144	731124.....	194
720627.....	129	721152.....	136	729119.....	134	730321.....	144	731130.....	194
720628.....	129	721153.....	136	729121.....	134	730335.....	141	731136.....	194
720632.....	129	721154.....	136	729122.....	135	730336.....	141	731142.....	194
720633.....	129	721155.....	136	729124.....	135	730338.....	140	731162.....	194
720634.....	129	721156.....	136	729163.....	134	730341.....	144	731164.....	194
720635.....	129	721157.....	136	729166.....	134	730352.....	143	731168.....	194
720641.....	129	721361.....	123	729169.....	135	730353.....	143	731174.....	194
720642.....	129	721362.....	123	729173.....	134	730401.....	145	731180.....	194
720644.....	129	721363.....	123	729176.....	135	730402.....	145	731186.....	194
720646.....	129	721372.....	123	729180.....	134	730403.....	145	731192.....	194
720648.....	129	729009.....	134	729183.....	135	730414.....	146	731204.....	195
720649.....	129	729011.....	134	729187.....	134	730415.....	146	731205.....	195
720653.....	129	729013.....	135	729190.....	135	730418.....	146	731214.....	195
720654.....	129	729015.....	135	729194.....	134	730423.....	145	731215.....	195
720656.....	129	729018.....	135	729197.....	135	730425.....	145	731238.....	194
720658.....	129	729020.....	135	729201.....	134	730428.....	145	731244.....	194
720659.....	129	729022.....	135	729204.....	135	730433.....	146	731256.....	194
720702.....	138	729025.....	134	729208.....	134	730435.....	146	731278.....	194
720812.....	127	729027.....	134	729211.....	135	730441.....	145	731284.....	194
720813.....	127	729028.....	134	729303.....	134	730442.....	145	731296.....	194
720814.....	127	729029.....	135	729306.....	135	730443.....	145	731453.....	195
720815.....	127	729031.....	135	729317.....	134	730452.....	140	735102.....	146
720817.....	127	729032.....	135	729320.....	135	730453.....	141	735252.....	150
720818.....	127	729034.....	135	729324.....	134	730454.....	140	735253.....	150
720821.....	127	729036.....	135	729327.....	135	730455.....	141	735254.....	150
720823.....	127	729039.....	135	729331.....	134	730456.....	141	735255.....	150
720824.....	127	729040.....	135	729334.....	135	730457.....	140	735256.....	150
720827.....	127	729042.....	134	729338.....	134	730458.....	141	735262.....	151
720832.....	127	729044.....	134	729341.....	135	730459.....	141	735264.....	151
720834.....	127	729046.....	135	729366.....	134	730462.....	141	735275.....	150
720835.....	127	729048.....	135	729369.....	135	730463.....	141	735301.....	155
720837.....	127	729051.....	135	729373.....	134	730464.....	140	735302.....	155
720841.....	127	729056.....	135	729376.....	135	730466.....	140	735303.....	155
720842.....	127	729061.....	134	729380.....	134	730467.....	141	735305.....	154
720843.....	127	729063.....	134	729383.....	135	730473.....	146	735311.....	155
720844.....	127	729065.....	135	729394.....	134	730483.....	145	735322.....	155
720845.....	127	729067.....	135	729397.....	135	730485.....	145	735323.....	155
720846.....	127	729070.....	135	729461.....	135	730488.....	145	735391.....	155
720848.....	127	729072.....	135	729462.....	135	730496.....	142	735403.....	195
720911.....	123	729075.....	135	729463.....	135	730554.....	142	739102.....	166, 168
720917.....	123	729078.....	134	729471.....	135	730555.....	142	739104.....	166, 168
720922.....	123	729080.....	134	729472.....	135	730556.....	142	739105.....	166, 168
720925.....	123	729081.....	134	729473.....	135	730557.....	142	739107.....	167, 168
720929.....	123	729082.....	135	729475.....	135	730558.....	142	739108.....	167, 168
720932.....	123	729084.....	135	729483.....	134	730559.....	142	739109.....	166, 168
721111.....	137	729085.....	135	729484.....	134	730701.....	143	739111.....	167, 168
721112.....	137	729087.....	135	730206.....	149	730702.....	143	739116.....	168
721113.....	137	729089.....	135	730207.....	149	730703.....	143	739122.....	168
721114.....	137	729092.....	135	730216.....	149	730704.....	143	739125.....	168
721115.....	137	729093.....	135	730217.....	149	730711.....	152	739133.....	169
721116.....	137	729095.....	134	730218.....	149	730724.....	152	739142.....	167
721117.....	137	729097.....	134	730221.....	146	730725.....	152	739181.....	170, 254
721141.....	136	729099.....	135	730222.....	148	730731.....	152	739191.....	168
721142.....	136	729101.....	135	730227.....	149	730736.....	152	739192.....	168

## Numerical Index

739193.....	168	740598.....	177	770302.....	282, 229	774909.....	114	775144.....	110
739194.....	168	740901.....	179	770312.....	229, 282	774910.....	114	775146.....	110
739195.....	168	740912.....	180	770313.....	229, 282	774911.....	114	775153.....	110
739197.....	168	740913.....	180	770314.....	229, 282	774912.....	114	775156.....	110
739198.....	168	740914.....	180	774607.....	114	774913.....	114	775162.....	111
740103.....	174	740915.....	180	774608.....	114	774914.....	114	775164.....	111, 114
740105.....	174	740926.....	180	774610.....	114	774915.....	114	775165.....	113, 114
740107.....	174	740927.....	180	774612.....	114	774917.....	114	775173.....	111, 114
740151.....	174	740928.....	180	774613.....	114	774919.....	114	775175.....	111, 114
740153.....	174	740932.....	181	774614.....	114	774956.....	114	775176.....	112, 114
740155.....	174	740933.....	181	774615.....	114	774957.....	114	775184.....	111, 114
740157.....	174	740934.....	181	774617.....	114	774958.....	114	775185.....	111, 114
740158.....	174	740952.....	178	774619.....	114	774959.....	114	775186.....	112, 114
740161.....	174	740953.....	178	774657.....	114	774960.....	114	775191.....	110
740163.....	174	740971.....	180	774658.....	114	774962.....	114	775192.....	110
740164.....	174	740972.....	180	774659.....	114	774964.....	114	775301.....	202
740165.....	174	740974.....	180	774660.....	114	774966.....	114	775306.....	202
740166.....	174	740975.....	180	774662.....	114	774968.....	114	775307.....	202
740174.....	175, 177	740977.....	180	774663.....	114	775005.....	114	775308.....	202
740175.....	175, 175	740978.....	180	774664.....	114	775006.....	114	775400.....	184
740176.....	175, 177	740979.....	180	774666.....	114	775007.....	114	775401.....	184
740178.....	177	740983.....	175	774668.....	114	775008.....	114	775402.....	184
740179.....	177	740984.....	175	774691.....	114	775009.....	114	775403.....	184
740191.....	175	740985.....	175	774692.....	114	775010.....	114	775404.....	184
740307.....	172	740994.....	181	774693.....	114	775011.....	114	775405.....	184
740321.....	173	740995.....	181	774694.....	114	775012.....	114	775406.....	184
740331.....	173	740996.....	181	774695.....	114	775013.....	114	775410.....	185
740347.....	172	740997.....	181	774696.....	114	775014.....	114	775411.....	185
740348.....	172	740998.....	181	774697.....	114	775015.....	114	775412.....	185
740381.....	173	740999.....	181	774698.....	114	775017.....	114	775413.....	185
740386.....	173	741107.....	179	774699.....	114	775019.....	114	775420.....	185
740403.....	179	741121.....	179	774756.....	114	775021.....	114	775421.....	185
740407.....	179	741123.....	179	774757.....	114	775022.....	114	775422.....	185
740522.....	178	741141.....	179	774758.....	114	775023.....	114	775423.....	185
740523.....	178	741142.....	179	774759.....	114	775025.....	114	775424.....	185
740524.....	178	760002.....	158	774760.....	114	775054.....	114	775425.....	185
740525.....	178	760202.....	159	774761.....	114	775056.....	114	775430.....	186
740526.....	178	760211.....	159, 160	774762.....	114	775057.....	114	775431.....	186
740528.....	178	760213.....	158, 159, 160	774763.....	114	775058.....	114	775432.....	186
740532.....	178	760214.....	158, 159, 160	774764.....	114	775059.....	114	775433.....	186
740533.....	178	760221.....	159, 160	774765.....	114	775060.....	114	775434.....	186
740534.....	178	760224.....	158, 159, 160	774766.....	114	775061.....	114	775435.....	186
740535.....	178	760226.....	158, 159, 160	774767.....	114	775063.....	114	775436.....	186
740536.....	178	760228.....	159, 160	774768.....	114	775064.....	114	775437.....	186
740538.....	178	760234.....	159, 160	774806.....	114	775065.....	114	775440.....	185
740560.....	177	760236.....	158, 159, 160	774807.....	114	775067.....	114	775441.....	185
740565.....	177	760262.....	159, 161	774808.....	114	775069.....	114	775442.....	185
740569.....	177	760263.....	159, 161	774809.....	114	775073.....	114	775443.....	185
740580.....	177	760265.....	159, 161	774810.....	114	775075.....	114	775452.....	184
740581.....	177	760266.....	159, 161	774811.....	114	775077.....	114	775453.....	184
740582.....	177	760267.....	159, 161	774812.....	114	775080.....	114	775454.....	184
740583.....	177	760312.....	158, 161	774813.....	114	775082.....	114	775455.....	184
740584.....	177	760322.....	158, 161	774814.....	114	775104.....	112	775456.....	184
740585.....	177	760341.....	158, 161	774815.....	114	775104.....	114	775457.....	184
740586.....	177	760352.....	158, 161	774817.....	114	775106.....	112	775461.....	186
740587.....	177	770132.....	228, 282	774819.....	114	775106.....	114	775462.....	186
740588.....	177	770133.....	282	774905.....	114	775108.....	112	775507.....	183
740589.....	177	770134.....	228, 282	774906.....	114	775108.....	114	775508.....	183
740593.....	177	770135.....	228, 282	774907.....	114	775112.....	110	775511.....	183
740596.....	177	770152.....	229, 282, 283	774908.....	114	775114.....	110	775513.....	183

## Numerical Index

775592.....	186	779277.....	322	842921.....	27	890181.....	338	900257.....	347
775910.....	196	779279.....	322	842926.....	27	890182.....	338	900258.....	347
775921.....	196, 343	779901.....	63	843002.....	29	890184.....	338	900259.....	346
775928.....	196, 343	718861 – 865.....	348	843003.....	29	890187.....	338	900261.....	347
775929.....	196, 343	841011.....	30	843004.....	29	890195.....	338	900262.....	347
775936.....	196	841021.....	30	843012.....	29	890407.....	339	900263.....	347
776001.....	198	841031.....	30	849403.....	200, 201	890426.....	339	900266.....	347
776002.....	198	841051.....	31	849407.....	201	890427.....	339	900267.....	347
776004.....	198	841056.....	31	849411.....	200, 201	890428.....	338	900268.....	347
776021.....	198	841061.....	31	849412.....	200, 201	890429.....	338	H1007.....	291
776022.....	198	841151.....	30	849416.....	201	890430.....	338	H1014.....	287
776055.....	197	842104.....	12	849481.....	201	890442.....	339	H1017.....	274
776060.....	197	842105.....	12	849482.....	201	890443.....	341	H1039.....	283
776061.....	197	842124.....	12	849491.....	201	890444.....	338	H1060.....	287
776065.....	197	842134.....	12	849492.....	201	890445.....	341	H1061.....	287
776070.....	197	842142.....	12	849493.....	201	890446.....	339	H1062.....	287
779112.....	193	842142.....	343	849494.....	201	890447.....	341	H1063.....	287
779113.....	193	842143.....	12, 343	849495.....	201	890451.....	341	H1066.....	295
779161.....	199	842144.....	12, 343	849804.....	324	890453.....	340	H1080.....	298
779162.....	199	842152.....	12	849806.....	324	890454.....	340	H1084.....	264
779201.....	190	842153.....	12	849807.....	324	890455.....	338	H1085.....	252
779203.....	190	842154.....	12	849809.....	324	890456.....	338	H1088.....	264
779205.....	190	842202.....	20	849814.....	324	890457.....	338	H1090.....	293
779211.....	192	842204.....	20	849815.....	324	890458.....	341	H1096.....	252
779212.....	192	842252.....	20	849891.....	324	890468.....	340	H1099.....	286
779213.....	192	842254.....	20	849892.....	324	890469.....	340	H1103.....	252
779214.....	192	842256.....	21	859042.....	153	890471.....	339	H1105.....	298
779215.....	192	842281.....	24	859043.....	153	890472.....	339	H1107.....	252
779216.....	192	842283.....	24	859044.....	153	890481.....	336	H1116.....	301
779218.....	192	842284.....	25	859211.....	193, 321	890482.....	336	H1120.....	254
779220.....	320	842286.....	25	859212.....	193, 321	890483.....	337	H1120A.....	254
779221.....	320	842480.....	21	859213.....	193, 321	890485.....	337	H1120B.....	254
779222.....	320	842481.....	21	859214.....	193, 321	890512.....	344	H1120C.....	254
779223.....	320	842503.....	13	859215.....	193, 321	890648.....	341	H1120D.....	254
779224.....	320	842513.....	14	859301.....	319	890679.....	336	H1120E.....	254
779231.....	192	842523.....	14	859302.....	319	890690.....	341	H1120F.....	254
779232.....	192	842542.....	15	859304.....	319	890698.....	341	H1120G.....	254
779233.....	192	842543.....	15	859305.....	319	890927.....	336	H1120H.....	254
779234.....	192	842553.....	13	859307.....	319	900202.....	346	H1120J.....	254
779240.....	320	842563.....	14	859308.....	319	900203.....	346	H1120K.....	254
779241.....	320	842573.....	14	859309.....	319	900204.....	346	H1121.....	254
779242.....	320	842602.....	17	859310.....	319	900205.....	346	H1121A.....	254
779243.....	320	842604.....	17	859311.....	319	900210.....	346	H1121B.....	254
779244.....	320	842613.....	18	859312.....	319	900215.....	346	H1121C.....	254
779252.....	190	842614.....	18	859313.....	319	900218.....	346	H1121D.....	254
779253.....	190	842623.....	19	859314.....	319	900219.....	346	H1121E.....	254
779255.....	190	842652.....	16	859315.....	319	900225.....	347	H1121F.....	254
779256.....	190	842653.....	16	859316.....	319	900226.....	347	H1121G Y.....	254
779258.....	192	842654.....	16	859317.....	319	900227.....	347	H1122.....	298
779261.....	191	842663.....	18	859341.....	318	900228.....	347	H1137.....	285
779262.....	191	842673.....	19	859342.....	318	900230.....	346	H1141.....	299
779263.....	191	842712.....	22	859343.....	318	900235.....	346	H1142.....	301
779264.....	191	842722.....	23	859344.....	318	900236.....	346	H1143.....	302
779266.....	322	842762.....	22	859345.....	318	900239.....	346	H1145.....	302
779267.....	322	842772.....	23	890171.....	340	900240.....	347	H1147.....	301
779268.....	322	842902.....	28	890172.....	340	900241.....	347	H1151.....	300, 301
779271.....	322	842907.....	28	890173.....	340	900246.....	346	H1152.....	301
779274.....	322	842909.....	28	890174.....	339	900251.....	347	H1175.....	274
779275.....	322	842911.....	26	890175.....	339	900252.....	347	H1176.....	274
779276.....	322	842916.....	26	890177.....	339	900253.....	346	H1179.....	253

## Numerical Index

H1179.....	253	H1503.....	300	H1845L.....	270	H2000UB.....	277	H3107.....	261
H1183.....	273	H1560.....	264	H1845M.....	271	H2000UC.....	277	H3116.....	295
H1185.....	273	H1670.....	272	H1845N.....	270	H2000UPA.....	277	H3125.....	291
H1229.....	298	H1670A.....	272	H1845P.....	270, 271	H2000V.....	277	H3128.....	266
H1230.....	298	H1670B.....	272	H1845Q.....	270	H2000W.....	277	H3129.....	266
H1244.....	298	H1670C.....	272	H1845R.....	270	H2000X.....	277	H3140.....	265
H1262.....	272	H1670D.....	272	H1845S.....	271	H2000XA.....	277	H3143.....	273
H1273.....	289	H1670E.....	272	H1845V.....	271	H2002.....	277	H3148.....	274
H1273A.....	289	H1670F.....	272	H1845W.....	270, 271	H2150.....	259	H3148A.....	274
H1273B.....	289	H1670G.....	272	H1845X.....	270, 271	H2151.....	259	H3148B.....	274
H1273C.....	289	H1670H.....	272	H1845Y.....	270	H2153.....	259	H3148C.....	274
H1273D.....	289	H1670I.....	272	H1858.....	288	H2155.....	259	H3148D.....	274
H1273E.....	289	H1670J.....	272	H1859.....	285	H2157.....	259	H3148E.....	274
H1274.....	295	H1670K.....	272	H1863.....	285	H2158.....	259	H3148F.....	274
H1278.....	253	H1670L.....	272	H1864.....	257	H2159.....	259	H3149.....	259
H1279.....	291	H1670M.....	272	H1864C.....	257	H2161.....	259	H3150.....	259
H1295.....	287	H1677.....	291	H1866.....	273	H2162.....	259	H3151.....	259
H1301.....	302	H1728.....	269	H1901.....	281	H2163.....	259	H3152.....	259
H1302.....	302	H1728A.....	269	H1902.....	263	H2164.....	259	H3153.....	259
H1304.....	293	H1730.....	268	H1903.....	281	H2166.....	259	H3162.....	299
H1345.....	290	H1730B.....	268	H1905.....	280	H2168.....	259	H3183.....	272
H1346.....	290	H1730C.....	268	H1907.....	263	H2169.....	259	H3192.....	279
H1361.....	293	H1730D.....	268	H1926.....	262	H2170.....	259	H3237DA.....	284
H1363.....	284	H1730E.....	268	H2000.....	277	H2171.....	259	H3241.....	287
H1363C.....	284	H1730F.....	268	H2000A.....	277	H2172.....	259	H3262.....	299
H1364.....	284	H1730H.....	268	H2000AB.....	277	H2176.....	259	H3264.....	300
H1365.....	289	H1731.....	268	H2000B.....	277	H2177.....	259	H3274.....	300
H1365A.....	289	H1734X.....	269	H2000B90.....	277	H2179.....	259	H3276.....	300
H1365B.....	289	H1841.....	257	H2000BK.....	277	H2186.....	259	H3282.....	302
H1365C.....	289	H1841A.....	257	H2000C.....	277	H2188.....	259	H3284.....	302
H1365D.....	289	H1843.....	257	H2000C90.....	277	H3041.....	269	H3290.....	265
H1365E.....	289	H1843A.....	257	H2000D.....	277	H3041B.....	269	H3295.....	273
H1386.....	298	H1843E.....	257	H2000DX.....	277	H3041C.....	269	H3308.....	259
H1440.....	290	H1843F.....	257	H2000E.....	277	H3041D.....	269	H3309.....	259
H1441.....	290	H1844.....	257	H2000F.....	277	H3042.....	268	H3310.....	287
H1442.....	290	H1844B.....	257	H2000G.....	277	H3042A.....	268	H3315.....	264
H1452.....	288	H1844E.....	257	H2000H.....	277	H3042B.....	268	H3316.....	265
H1453.....	288	H1845.....	270	H2000HA.....	277	H3042C.....	268	H3317.....	265
H1454.....	288	H1845-2.....	270	H2000HH.....	277	H3042D.....	268	H3318.....	265
H1455.....	288	H1845-3.....	270	H2000J.....	277	H3042K.....	268	H3319.....	265
H1456.....	288	H1845-4.....	270	H2000K.....	277	H3047.....	258	H3327.....	278
H1458-10.....	288	H1845-5.....	270	H2000KA.....	277	H3052.....	284	H3341.....	279
H1458-11.....	288	H1845A.....	270	H2000KB.....	277	H3055.....	287	H3342.....	253
H1458-12.....	288	H1845B.....	270	H2000KC.....	277	H3056.....	288	H3344.....	293
H1458-13.....	288	H1845C.....	270	H2000L.....	277	H3060.....	263	H3346.....	278
H1458-14.....	288	H1845D.....	271	H2000M.....	277	H3061.....	263	H3351.....	275
H1458-15.....	288	H1845DD.....	270	H2000M11.....	277	H3070.....	252	H3352.....	276
H1458-16.....	288	H1845E.....	270, 271	H2000M15.....	277	H3071.....	263	H3353.....	276
H1458-17.....	288	H1845EE.....	271	H2000M16.....	277	H3071A.....	263	H3354.....	276
H1486.....	260	H1845F.....	271	H2000N.....	277	H3071B.....	263	H3355.....	276
H1493.....	293	H1845FF.....	271	H2000NN.....	277	H3078.....	287	H3356.....	276
H1502.....	255	H1845G.....	270	H2000OP.....	277	H3079.....	287	H3357.....	276
H1502A.....	255	H1845GG.....	270	H2000Q.....	277	H3086.....	299	H3358.....	276
H1502B.....	255	H1845H.....	270	H2000R.....	277	H3089.....	275	H3359.....	276
H1502C.....	255	H1845H.....	271	H2000RA.....	277	H3090.....	287	H3364.....	275
H1502D.....	255	H1845HH.....	271	H2000RK.....	277	H3092.....	283	H3370.....	286
H1502E.....	255	H1845J.....	270	H2000S.....	277	H3095.....	288	H3371.....	286
H1502F.....	255	H1845K.....	271	H2000T.....	277	H3096.....	288	H3372.....	286
H1502G.....	255	H1845KK.....	270	H2000U.....	277	H3103.....	298	H3373.....	286
H1502H.....	255	H1845L.....	270	H2000UA.....	277	H3105.....	285	H3374.....	286



## Numerical Index

H3375	286	H3573-19	290	H3700-14	286
H3376	286	H3573-20	290	H3700-15	286
H3377	286	H3573-21	290	H3700-16	286
H3378	286	H3573-22	290	H3700-17	286
H3379	286	H3573-23	290	H3700-18	286
H3380	286	H3573-24	290	H3700-19	286
H3381	286	H3573-25	290	H3700-20	286
H3382	286	H3573-26	290	H3700-21	286
H3383	286	H3573-27	290	H3700-22	286
H3384	286	H3573-28	290	H3700-23	286
H3391	291	H3573-29	290	H3702	286
H3400	289	H3573-30	290	H3702-10	286
H3400C	289	H3573-31	290	H3702-11	286
H3400D	289	H3573-32	290	H3702-12	286
H3400E	289	H3573-33	290	H3702-13	286
H3400F	289	H3573-34	290	H3704	295
H3400G	289	H3573-35	290	HTA1000	305
H3400H	289	H3573-36	290	HTA1106	304
H3400J	289	H3573-37	290	HTA1108A	306
H3400K	289	H3573-38	290	HTA1109	304
H3405	260	H3573-39	290	HTA1117	306
H3406	260	H3573-40	290	HTA1118	304
H3407	261	H3573-41	290	HTA1118A	306
H3432	292	H3573-42	290	HTA1118B	306
H3433	287	H3573-43	290	HTA1125	304
H3434	287	H3573-44	290	HTA1136	304
H3437	258	H3573-45	290	HTA1136A	306
H3440	278	H3573-46	290	HTA1136B	306
H3444	255	H3573-47	290	HTA1136C	306
H3448	262	H3573-48	290	HTA1144	304
H3456	272	H3573-49	290	HTA1144A	306
H3501	275	H3580	278	HTA1144B	306
H3502	255	H3583	278	HTA1144C	306
H3502-10	255	H3586	278	HTA1146A	306
H3502-11	255	H3595	278	HTA1150	304
H3502-12	255	H3601	261	HTA1152A	306
H3502-13	255	H3604	260	HTA1153	304
H3512	298	H3609	262	HTA1154	304
H3529	267	H3612	262	HTA1156	304
H3530	266	H3614	262	HTA1216	304
H3531	267	H3616	263	HTA1312A	306
H3533	259	H3630	296	HTA1312B	306
H3536	264	H3650	292	HTA1312C	306
H3537	264	H3655	292	HTA1401	305
H3538	258	H3659	294	HTA1402	305
H3540	262	H3659-11	294	HTA1403	305
H3544	275	H3660	294	HTA1404	305
H3560	281	H3661	294	HTA1819	306
H3562	280	H3662	303	HTA1820	306
H3565	279	H3664	303	HTA1830	306
H3566	280	H3666	303	HTA1831	305
H3573-10	290	H3668	303	HTA1832	305
H3573-11	290	H3670	303	HTA1833	305
H3573-12	290	H3672	303	HTA1834	305
H3573-13	290	H3674	303	HTA1835	305
H3573-14	290	H3700	286		
H3573-15	290	H3700-10	286		
H3573-16	290	H3700-11	286		
H3573-17	290	H3700-12	286		
H3573-18	290	H3700-13	286		

# Alphabetical Index

## A

Adjustable Spanner Wrenches .....	108
Adjustable Wrenches .....	104-105
Air Chucks .....	302
Air Inflator Gauges .....	302
Anti-Fatigue Mats .....	217
Automotive Gauges .....	304-305
Axes and Mauls .....	179

## B

Ball Joint Service Set .....	264
Bandsaws .....	224-225
Bars - Powerclaw™ Series .....	190-193
Battery Carrier .....	291
Battery Service .....	291-292
Bearing Packers .....	258
Bearing Separators .....	229, 282
Bench Grinders .....	220
Blow Guns .....	279
Bolt & Rod Cutters .....	194-195
Brake and Rotor Tools .....	312
Brake Repair Tools .....	252, 255

## C

Calipers .....	308
Chalk Line Set .....	199
Chests and Roller Cabinets .....	13-21
Chisel Point Scrapers .....	318
Chrome Sockets .....	41-71
Clamping .....	204-208
Clamping - C-Clamps .....	204-205
Clamping - L-Clamps .....	206-207
Clamps - Pipe .....	208
Clamps - Spring Hand .....	208
Compression & Pressure Testers .....	268-271
Construction Tools .....	188-202
Coupler Adaptors	
- Quick Change .....	235-236
Cutters .....	139-155
Cutters - Bolt & Rod .....	194-195
Creepers / Roller Seats .....	215-216
Crowfoot Wrenches .....	103
Cylinder Honers - Abrasive .....	257

## D

Deburring Tools .....	168
Display Merchandisers .....	334-345
Drill Presses .....	221-223
Drive Socket Sets .....	80-82
Driver Bits & Sockets .....	288
Drum Handling .....	249
Dust Collector .....	226

## E

Electrical Tester .....	293, 296
External TORX® .....	59, 66, 85

## F

Fan Clutch Wrenches .....	266-267
Feeler Gauges .....	285
Filter Wrenches .....	286-287
Flaring Tool Kits .....	254-255
Flaring Tools .....	169-170

Flashlights .....	324
Fluid Line Tools .....	275-276
Fluid Transfer .....	239-248
Front End Service Tools .....	262-264
Front Wheel Drive Axle Nut Tools .....	259
Fuel and Gasoline Pumps .....	245-246

## G

Gauges .....	311
Gear Pullers .....	282-283
Gear Pullers - Heavy Duty .....	228-229
Grease Fittings .....	237-238
Grease Gun Accessories .....	235-236
Grease Gun Couplers .....	236
Grease Gun Holders .....	236
Grease Gun Hoses .....	233
Grease Guns .....	232-234
Grease Pump Accessories .....	240
Grease Pumps .....	239

## H

Hacksaws .....	202
Hammers - Ball Pein .....	174-175
Hammers - Club .....	175
Hammers - Drilling .....	178
Hammers - Indestructible Handle .....	177
Hammers - Nailing .....	172-173
Hammers - Sledge .....	178
Hammers - Soft Face Dead Blow ....	180-181
Hammers - Welding .....	179
Hand Brushes .....	283
Hex & Torx® Bits Open Stock .....	90
Hex Bit Socket Sets - Chrome .....	56-57
Hex Bit Socket Sets - Impact .....	84-85
Hex Key Wrenches .....	110-114
Hose & Clamp Tools .....	265-266

## I

Ignition Tools .....	294-295
Impact Socket Accessories .....	86-87
Impact Socket Sets .....	74-77
Impact Sockets Open Stock .....	88-89
Indicators .....	309
Insert Bits .....	134

## J

JobSite Tool Storage .....	21
----------------------------	----

## K

Knives .....	284
--------------	-----

## L

Levels .....	198-199
Locknut Tools .....	260-261
Lubrication & Fluid Transfer .....	232-234

## M

Mag Wheel Sockets .....	78
Magnetic Bases .....	310
Magnetic Pick-Up Tools .....	298-299
Mallets - Rubber .....	179
Measuring Tools .....	196-199
Mechanic's Tools .....	316-322
Merchandisers .....	336-345

Metal Working Machinery .....	224-225
Meters - Digital .....	315
Micrometers .....	310-311
Mirrors .....	298-299
Muffler Expanders .....	274

## N

Nail Gun .....	200
Nail Puller .....	190-191, 193
New Products .....	336-337
Nut Drivers .....	136-137, 161
Nutsetters .....	135

## O

Oil and Fuel Pumps .....	242-244
Oil Drains .....	247-248
Oil Filter Wrenches .....	286-287
Open Front Tool Chests .....	24-25

## P

Parts Washers .....	214
Pick, Hook and Scraper Tools .....	319
Pipe Cutter .....	167
Pipe Wrenches .....	164-165
Piston Ring Tools .....	272
Pliers - Automotive .....	287, 288
Pliers - Chrome Nickel Series .....	147-149
Pliers - Chrome Vanadium .....	144, 146
Pliers - Locking .....	140-142
Pliers - Long Reach Series .....	145
Pliers - Snap Ring .....	143
Pliers For Wheel Weights .....	301
Portable Tool Boxes .....	12
Post & Terminal Service .....	291
Power Bits .....	135
Precision Measuring Tool Kit .....	309
Pressure Testers .....	274
Pressure Testers .....	277
Pry Bars .....	320-322
Pullers & Puller Kits .....	279-281
Punch and Chisel - Open Stock .....	184-186
Punch and Chisel - Sets .....	182-183
Punches - Brass .....	288

## R

Ratchet Wrench .....	98-102
Ratcheting Breaker Bars .....	68
Ratcheting Cutter .....	168
Ratcheting Driver .....	131-133
Ratcheting Pry Bars .....	322
Ratcheting Screwdrivers .....	131-133
Ratchets .....	34-40
Replacement bits .....	351
Replacement Parts .....	306
Replacement wear Parts .....	346-349
Ring Compressor .....	272
Rivet Guns .....	153
Rivet Tools .....	153

## S

Saws .....	202
Scrapers/Knives .....	284
Screw Extractors .....	289
Screwdriver Bits .....	134-135
Screwdrivers .....	122-128, 138, 289
Seal Puller .....	284
Service Carts .....	26-27

## Alphabetical Index

Shears.....	150-151
Sheet Metal Tools.....	154-155
Shop Carts .....	28
Snips - Aviation .....	154-155
Socket Wrench Sets - Chrome.....	42-49
Socket Accessories - Chrome.....	67-72
Socket Accessories - Impact.....	86-87
Socket Sets - Chrome.....	50-55
Socket Sets - Impact.....	74-78
Sockets - Automotive.....	278
Spark Plug Sockets .....	60, 295
Spark Plug/Ignition Tools .....	294-295
Specialty Pullers .....	282
Squares .....	197
Stamps - Number / Letter.....	187
Staplers and Tackers .....	200-201
Stethoscope .....	272
Striking Tools.....	171-187
Suspension Tools .....	260-264
Stud, Bolt & Nut Removal.....	288

### T

Tape Measure.....	196
Tachometers.....	306
Taps, Dies & Thread Repair.....	290
Testing Equipment.....	292
Thermometers.....	313
Tire Pressure Gauges .....	299-301
Tire Valve Tools .....	301
Tool Chest & Organizers.....	13-21
Tool Organizers.....	30-31
Torque Limiting Extensions.....	79
Torque Multipliers .....	120
Torque Wrenches.....	116-119
TORX® Bit Socket Sets .....	58, 84
TORX® Bits Open Stock.....	66
Truck Tire Socket Sets.....	83
Truck Wheel Bearing Locknut Sockets .....	259
Tube Benders & Cutters .....	166-167, 253
Tune-Up Tools .....	272-273

### U

Upholstery Tools .....	303
------------------------	-----

### V

Valve Lapping Tools.....	273
Valve Spring Compressors.....	272
VDE Tools .....	158-161
Vises.....	209-211

### W

Warrantly Policy .....	350
Water, Chemical & Oil Pumps .....	241-242
Wire Strippers and Cutters.....	152
Wood Working.....	226
Workbenches .....	29
Wrecking Bar.....	190-191
Wrenches .....	92-108
Wrenches - Adjustable.....	104-105
Wrench - Ratcheting .....	98-102
Wrenches - Combination.....	92-97
Wrenches - Flare Nut.....	103
Wrenches - Fully Polished.....	94-95
Wrenches - Multi-fit .....	96
Wrenches - Raised Panel .....	92-93
Wrenches - Structural.....	107
Wrenches- Striking .....	106



## Trademark Information

Vehicle manufacturers' names and models, are used in this catalogue as a common reference point and for no other reason. JET Equipment & Tools Ltd. does not sponsor or endorse said manufacturers. All trademarks are the property of respective owners.

ANSI is a registered trademark of American National Standards Institute

Audi and the names of specific products/Models are the registered trademarks of AUDI AG.

BENDIX is a registered trademark of Bendix Commercial Vehicle Systems, LLC

CAT and Caterpillar are registered trademarks of Caterpillar Inc.

Cummins is a trademark of Cummins Inc.

Detroit Diesel is a registered trademark of Detroit Diesel Corp.

Ford and the names of specific products/models are the registered trademarks of Ford Motor Company

GM, Chevrolet, Pontiac, Oldsmobile, Buick, Cadillac, GMC, Blazer and HUMMER are registered trademarks of General Motors of Canada Limited (GMCL)

Honda is a registered trademark of Honda Motor Co., Ltd

International Harvester is a registered trademarks of CNH Global N.V.

ISUZU and the names of specific Isuzu products are trademarks of Isuzu Motors Limited or Isuzu Motors America, LLC,

Jeep, Wrangler, Cherokee, Grand Cherokee, Dodge, RAM and other models are trademarks of Chrysler Group LLC

John Deere is a registered trademark of Deere & Company

Kubota is a registered trademark of Kubota Tractor Corporation

Land Rover is a registered trademark of Land Rover Canada, Rover Group Limited

Leyland is a registered trademark of LEYLAND TRUCKS LIMITED

MacPherson struts is a registered trademark of Ford Motor Corporation

Mazda and the names of specific products/models are the registered trademarks of Mazda Motor Corporation

MERCEDES BENZ is a registered trademark of DaimlerChrysler Corp.

Mini and BMW, and the names of specific products/Models are the registered trademarks of Bayerische Motoren Werke Aktiengesellschaft

Mitsubishi and the names of specific products/models are the registered trademarks of Mitsubishi Motors Corporation

Navistar is a registered trademark of Navistar Int. Transportation Corp

Nissan and the names of specific products/models are the registered trademarks of Nissan Motor Co. Ltd

Renault is a registered trademark of Renault s.a.s. Corporation

SCANIA is a trademark of Scania CV Aktiebolag

Subaru is a registered trademark of Subaru division of Fuji Heavy Industries, Ltd, Japan.

Toyota, and the names of specific products/models are the registered trademarks of Toyota Motor Corporation

Volkswagen is a trademark of Volkswagen AG.

Volvo and the names of specific products/models are the registered trademarks of AB Volvo and Volvo Car Corporation





Special thanks to our JET customers for making our photo shoots possible.



**HPA Motorsports Inc.**  
Langley, BC

**Precision Diesel Tech**  
Vancouver, BC

**Design Machine Tech**  
Maple Ridge, BC



## ABRASIVES



## AIR TOOLS

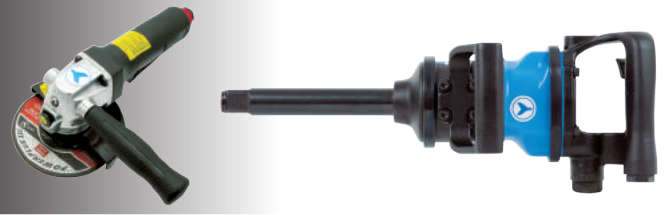

## HAND TOOLS



## INDUSTRIAL POWER EQUIPMENT

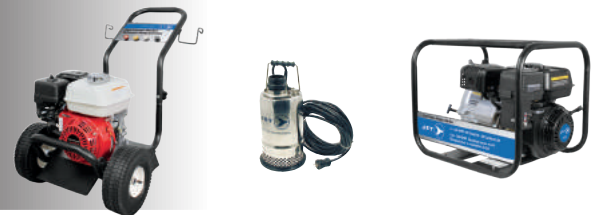

## MATERIAL HANDLING



## **STRONGARM** LIFTING & HYDRAULIC EQUIPMENT





# PROFESSIONAL PRODUCTS. PROFESSIONAL RESULTS.

**J E T** G R O U P

Contact your nearest distributor for  
complete information on our product lines.

[www.jetgroupbrands.com](http://www.jetgroupbrands.com)



**\$5.95 CDN**